

POLY-NORM®-M Type AFN Flexible couplings

Three-part



- Torsionally flexible
- Maintenance-free
- Fail-safe
- Damping vibrations
- Axial plug-in
- Compensating for misalignment

Components

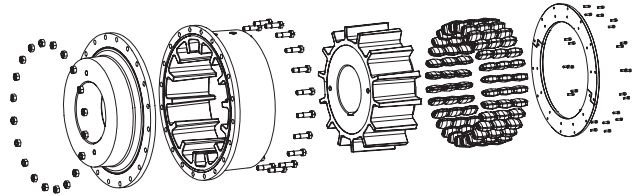
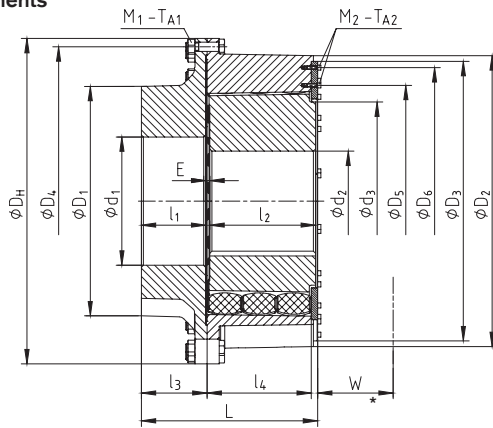

POLY-NORM®-M Type AFN																											
Size	Torque ¹⁾ [kNm]		Dimensions [mm]																	Dowel screw (10.9)		Screws DIN EN ISO 4762			Approx. weight ²⁾ [kg]		
	T _{KN}	T _{Kmax}	Max. finish bore Ød		General															z	M ₁	T _{A1} [Nm]	z	M ₂		T _{A2} [Nm]	
			d ₁	d ₂	L	l ₁	l ₂	l ₃	l ₄	D _H	D ₁	D ₂	D ₃	D ₄	D ₅	D ₆	d ₃	E	W								
202	100	200	350	200	425	195	215	200	218	640	500	552	530	600	360	480	300	12	150	24	M24	970	16	M16	290	430	
252	140	280	355	250	438	208	215	213	218	720	550	635	610	680	460	570	360	12	150	30	M24	970	18	M16	290	590	
302	200	400	380	300	464	203	247	209	255	770	600	682	660	730	510	625	430	13	175	20	M24	970	24	M16	290	730	
402	400	800	480	400	580	224	335	230	350	1000	760	885	860	945	650	800	530	14	250	18	M30	1950	20	M16	290	1750	
502	650	1300	650	500	654	228	407	234	360	1200	1000	1080	1050	1140	830	990	700	19	250	24	M30	1950	24	M16	290	2240	
503	950	1900	650	500	777	228	530	234	505	1200	1000	1075	1340	1140	830	990	700	19	415	24	M30	1950	24	M16	290	3090	
703	1200	2400	700	700	845	309	507	315	500	1560	1100	1395	1340	1480	1110	1280	950	19	360	20	M42	3600	28	M16	290	5150	
803	2400	4800	1000	800	1030	406	600	416	530	1800	1600	1630	1550	1720	1250	1450	110	24	390	24	M48	5450	28	M24	970	9300	
903	3300	6600	1000	900	982	406	541	412	550	2060	1400	1865	1800	1975	1500	1730	1300	25	390	24	M48	5450	32	M24	970	9800	
905	5500	11000	1000	900	1377	406	857	417	920	2060	1650	1865	1800	1975	1500	1730	1300	114	715	40	M48	5450	32	M24	970	14800	

* Drop-out center dimension

¹⁾ Standard material NBR 80 Shore A, please observe selection on page 14 et seq. in the Drive Technology catalogue.

²⁾ Relating to max. bore

Other types

Type AFN with clamping ring hub

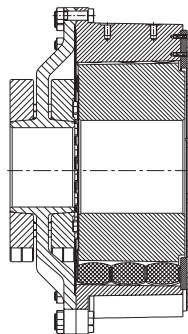

Ordering example:	POLY-NORM®-M	Type	d ₁ Ø500	d ₂ Ø450
	Size	AFN	finish bore	finish bore