

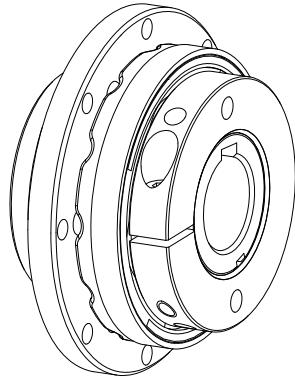

SYNTEX[®] design DK

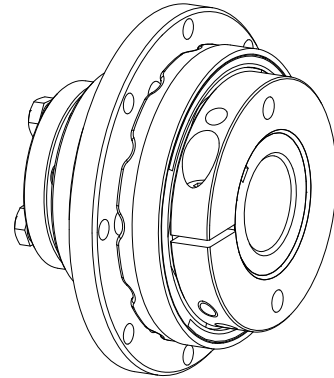

Hub design 1.0



Hub design 4.5

The **SYNTEX[®]** is an overload system with positive locking. It protects the following components against destruction. The design DK (ratchet) re-engages after 30° each into the following lock-in position in case of an overload.

Table of Contents

1 Technical Data

2 Hints

- 2.1 General Hints
- 2.2 Safety and Advice Hints
- 2.3 General Hints to Danger
- 2.4 Proper Use

3 Storage

4 Assembly

- 4.1 Components SYNTEX[®]-Overload System
- 4.2 Assembly (General)
- 4.3 Adjustment of the Torque of Engagement
- 4.4 Adjustment of the Torque of Engagement after the Disassembly
- 4.5 Assembly SYNTEX[®]-Overload System
- 4.6 Limit Switch
- 4.7 Spares Inventory, Customer Service Addresses



1 Technical Data

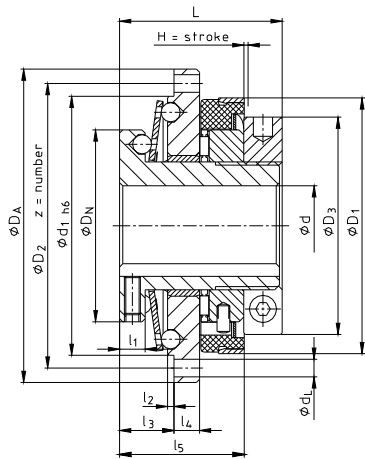

illustration 1: hub design 1.0

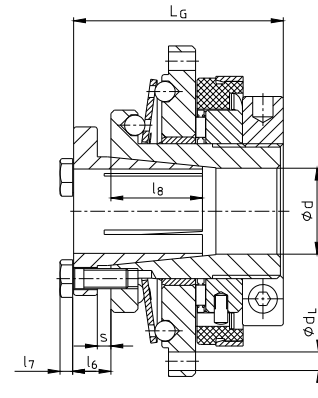

illustration 2: hub design 4.5

Table 1: dimensions

Size	Max. finish bore d [mm]	Dimensions [mm]														z	H (stroke)
		D_A	D_2	d_1	D_N	D_3	D_1	d_L	L	l_1	l_2	l_3	l_4	l_5			
20	20	20	71	65	48	54	61,5	4,5	45	8	2	16	6	35	8	2	
25	25	25	89	81	60	68	80	5,5	50	8	2	17	8	39	8	2	
35	35	35	110	102	75	78	91	5,5	60	10	2	21	10	42	12	2	
50	50	50	152	142	105	108	121	6,6	70	12	2	25	13	56	12	2	

Table 2: dimensions hub design 4.5

Size	Dimensions [mm]					Clamping screws		
	l_6	l_7	l_8	L_G	s	M	Number	T_A [Nm]
20	9	3,5	23	54	3	M5	4	8,5
25	11	4,0	28	61	4	M6	4	14
35	10	4,0	31	70	4	M6	4	14
50	12	4,0	37	82	6	M6	4	14

Table 3: technical data

Size	Max. speed [min^{-1}]	Torques [Nm]	
		DK1	DK2
20	1500	6 – 20	15 – 30
25	1500	20 – 60	45 – 90
35	1000	25 – 80	75 – 150
50	1000	60 – 180	175 – 300

Table 4: transmittable friction torques of hub design 4.5

Size	Bores and the corresponding transmittable friction torques * T_R [Nm]																						
	12	14	15	16	17	18	19	20	22	23	24	25	28	30	32	35	38	40	42	45	48	50	
20	45	62	71	81	92	103	115	127															
25		72	83	95	107	120	133	148	179	196	213	231											
35									127	139	152	165	207	237	270	323							
50																238	281	311	343	394	448	486	

* fit H7/h6



2 Hints

2.1 General Hints

Please read through these mounting instructions carefully before you set the coupling into operation. Please pay special attention to the safety instructions!
The mounting instructions are part of your product. Please keep them carefully and close to the coupling. The copyright for these mounting instructions remains with KTR Kupplungstechnik GmbH.

2.2 Safety and Advice Hints



DANGER!

Danger of injury to persons.



CAUTION!

Damages on the machine possible.



ATTENTION!

Pointing to important items.

2.3 General Hints of Danger



DANGER!

With assembly, operation and maintenance of the coupling it has to be made sure that the entire drive train is protected against unintentional engagement. You can be seriously hurt by rotating parts. Please make absolutely sure to read through and observe the following safety instructions.

- All operations on and with the coupling have to be performed taking into account "safety first".
- Please make sure to disengage the power pack before you perform your work.
- Protect the power pack against unintentional engagement, e. g. by providing hints at the place of engagement or removing the fuse for current supply.
- Do not touch the operation area of the coupling as long as it is in operation.
- Please protect the coupling against unintentional touch. Please provide for the necessary protection devices and caps.

2.4 Proper Use

You may only assemble, operate and maintain the coupling if you

- carefully read through the mounting instructions and understood them
- had technical training
- are authorized to do so by your company

The coupling may only be used in accordance with the technical data. Unauthorized modifications on the coupling design are not admissible. We do not take any warranty for resulting damages. To further develop the product we reserve the right for technical modifications.

The **SYNTEX®** described in here corresponds to the technical status at the time of printing of these mounting instructions.

Please note protection mark ISO 16016.	Drawn: 15.08.13 Kb/Koh	Replaced for: KTR-N valid from 30.06.10
	Verified: 23.08.13 Kb	Replaced by:



3 Storage

The coupling hubs are supplied in preserved condition and can be stored at a dry and roofed place for 6 - 9 months.



CAUTION!

Humid storage rooms are not suitable.

Please make sure that there is no condensation. The best relative air humidity is under 65%.

4 Assembly

The SYNTEX®-overload system is delivered in assembled condition.

4.1 Components SYNTEX®-Overload System

Components SYNTEX®-overload system with hub design 1.0

Component	Quantity	Designation
1	1	Hub (design 1.0)
2	1	Disc spring
3	1	Flange ring
4	1	Setting ring
5	1	Shifting ring
6	1	Setting nut
7	1	Slide bush
8	1	Axial needle spider
9	1	Shaft lock washer
10	1	Set screw DIN EN ISO 4762
11	1	Grub screw DIN EN ISO 4029
12	1	Grub screw with tappet DIN EN ISO 4028
13	3	Half length reserve taper grooved dowel pin DIN EN ISO 8741
14	6	Round head grooved pin DIN EN ISO 8746
15	18	Ball DIN 5401

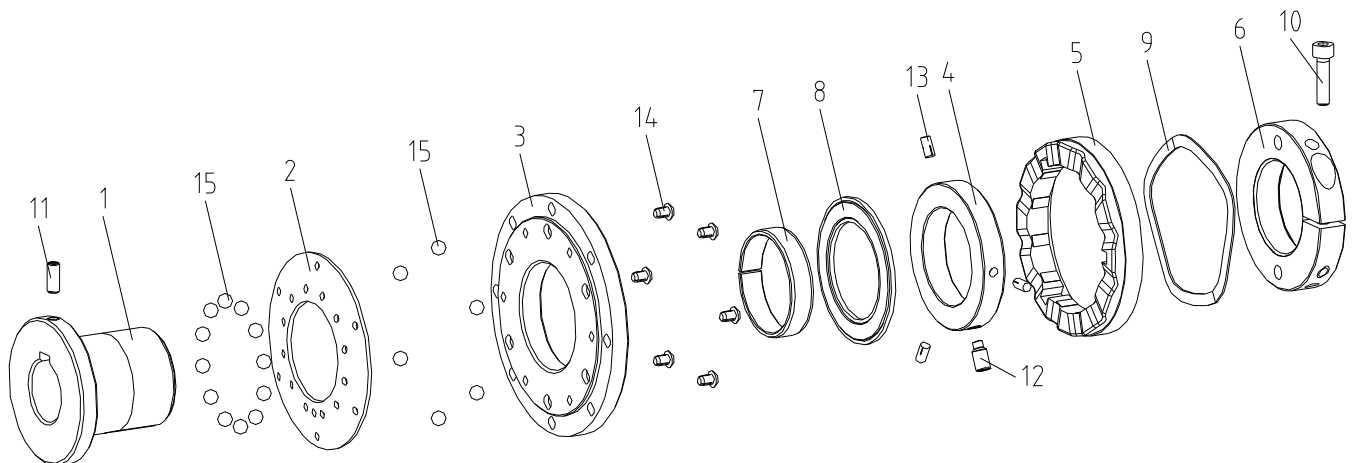

illustration 3: SYNTEX® DK hub design 1.0



4 Assembly

4.1 Components SYNTEX®-Overload System

Components SYNTEX®-overload system with hub design 4.5

Component	Quantity	Designation
1.1	1	Hub (design 4.5)
1.2	1	Clamping bush
1.3	4	Clamping screws DIN EN ISO 4017
2	1	Disc spring
3	1	Flange ring
4	1	Setting ring
5	1	Shifting ring
6	1	Setting nut
7	1	Slide bush
8	1	Axial needle spider
9	1	Shaft lock washer
10	1	Set screw DIN EN ISO 4762
11	1	Grub screw with tappet DIN EN ISO 4028
12	3	Half length reserve taper grooved dowel pin DIN EN ISO 8741
13	6	Round head grooved pin DIN EN ISO 8746
14	18	Ball DIN 5401

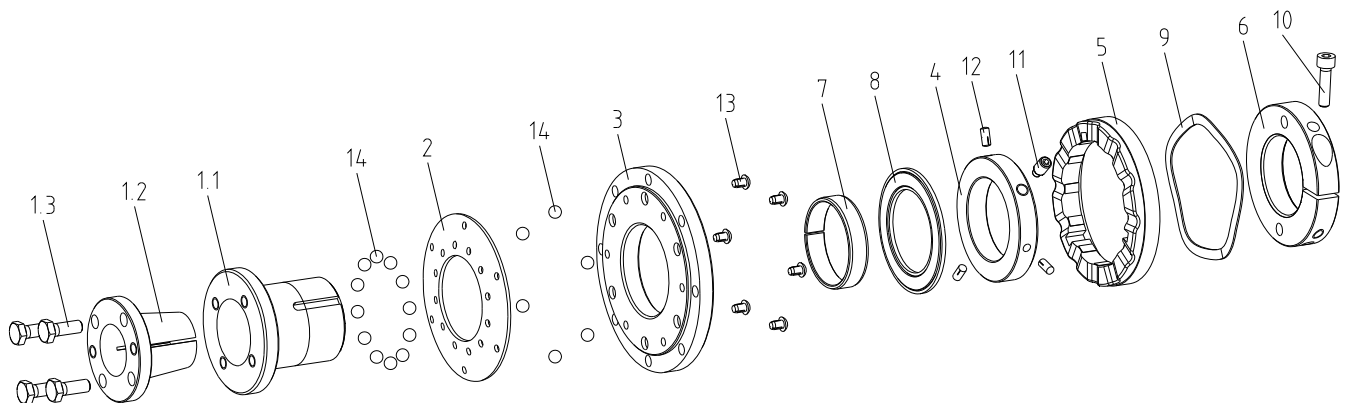

illustration 4: SYNTEX® DK hub design 4.5

4.2 Assembly (General)



ATTENTION!

We recommend to check bores, shaft, keyway and feather key for dimensional accuracy before assembly.

- Please make sure the perfect technical condition of the **SYNTEX®**-overload system.
- Before assembly and operation please check whether it is necessary to clean the components.
- Lubricate the balls (e. g. Klüber-Microlube GL 263).
- Please only use original components.



4 Assembly

4.3 Adjustment of Torque of Engagement

- Fix the hub against twisting.
- Unscrew the set screw in the setting nut.
- Rotate the setting nut (clockwise for higher torque of engagement, anticlockwise for lower torque of engagement) to the desired twisting angle with a sickle spanner (see table of torque of engagement).



CAUTION!
The SYNTEX®-overload system must not exceed the max. torque of engagement!

- When the desired torque of engagement is adjusted, fix the setting nut by screwing down the set screw on the threaded portion of the hub.

Table of torque of engagement:

Twisting angle setting nut	Torque of engagement [Nm]							
	Size 20		Size 25		Size 35		Size 50	
	Spring DK1	Spring DK2	Spring DK1	Spring DK2	Spring DK1	Spring DK2	Spring DK1	Spring DK2
30°	5							
60°	7		20		25		57	
90°	8	15	23		28		65	
120°	9	17	25		32		73	
150°	11	20	29		35		80	
180°	13	23	33	46	38		88	
210°	15	25	37	52	40	78	95	
240°	17	27	41	58	45	86	100	
270°	18	29	45	64	49	93	110	
300°	20	30	49	70	53	100	118	
330°			52	76	57	108	126	175
360°			55	82	61	115	134	188
390°			58	86	66	122	142	200
420°			60	90	71	129	150	212
450°					74	136	157	225
480°					77	143	165	237
510°					80	150	172	250
540°							180	262
570°								275
600°								288
630°								300

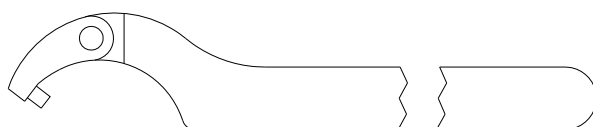

illustration 5: hinged hook wrench

SYNTEX® size	Hinged hook wrench with tappet
20	Ø35 - 60 x 5
25	Ø60 - 90 x 6
35	Ø60 - 90 x 6
50	Ø90 - 155 x 8



4 Assembly

4.4 Adjustment of the Torque of Engagement after the Disassembly

- Insert the balls with grease (e. g. Klüber - Microlube GL 263) into the pocket hole bores of the hub (12 balls) and of the flange ring (6 balls).
- Put the disc spring with the concave side onto the flange ring, whereby the balls must engage into the disc spring bores (please observe partition).
- Push the flange ring with the disc spring onto the hub and align the flange marking (bore) with the external keyway of the hub.
- Check the correct position of all balls in the bores.
- Push on the axial needle bearing.
- Push on the setting ring, the large external chamfer is directed to the hub thread.
- Put the shifting ring with the keyways on the face into the correct position to the round head grooved pins and put it onto the setting ring (please observe partition). Furthermore the pins grip from the setting ring into the axial keyways of the shifting ring.
- Check the function of the shifting ring (axial stroke $\geq 2\text{mm}$).
- Push the shaft lock washer onto the setting ring and into the shifting ring.
- Tighten the setting nut with the set screw clockwise and handset up to the limit stop.
- Adjust the desired torque of engagement by twisting the setting nut clockwise with a sickle spanner (see table of torque of engagement).
- The setting nut must be secured by tightening the set screw.

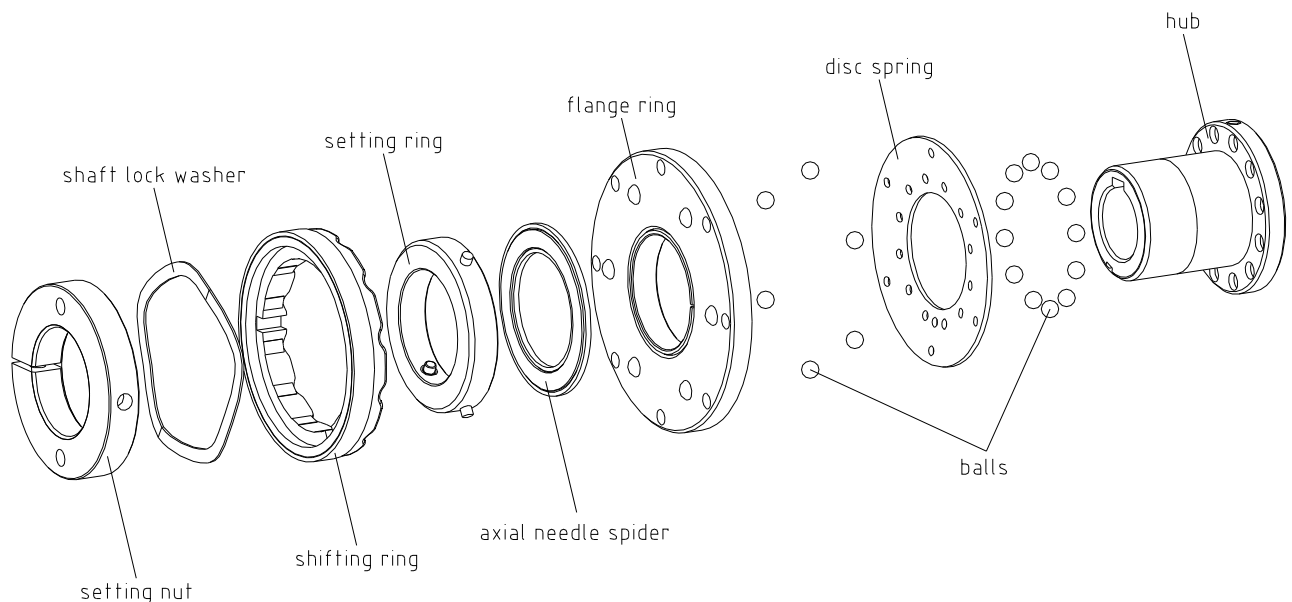

illustration 6



4 Assembly

4.5 Assembly SYNTEX®-Overload System

Feather key connection

For the axial fixing of the SYNTEX® - overload system with cylindrical finish bore (standard: ISO fit - H7) and feather key (standard: DIN 6885, page 1 - JS9), there are the following possibilities:

1. Tighten the grub screw on the feather key or the shaft.
2. Secure the hub with an end plate and a screw. The grub screw must be removed.

Clamping set connection

Please ask for the special mounting instruction for the respective clamping set.
Please consider the assembly situation.

Hub design 4.5

Tighten all pressure screws successively in several rotations until all screws have reached the full tightening torque (see table 1).

4.6 Limit Switch

Operation

The axial thrust of the shifting ring arising in the event of overload operates a mechanical limit switch or an inductive sensor. Consequently a control operation is performed to disengage the drive.

Assembly

The sensor has to be mounted in a solid device in order to ensure a smooth operation. The sensor should be protected against dirt and potential mechanical disorders.

Adjustment

When the overload coupling slips, the shifting ring makes an axial thrust of about 2 mm. The sensor or limit switch, respectively, has to be mounted within this shifting range. In order to adapt the mechanical limit switch and the shifting process to the machine, the limit switch has to be adjusted accordingly. For that purpose the shifting process can be regulated after opening the cover plate on the tappet.



CAUTION!

Before delivery of the machine please make absolutely sure to check the operation of the limit switch. Please also note the operating instructions for the sensor or limit switch, respectively. The axial thrust of the hub must not be obstructed by other components.

4.7 Spares Inventory, Customer Service Addresses

A basic requirement to guarantee the operational readiness of the coupling is a stock of the most important spare parts on site.

Contact addresses of the KTR partners for spare parts and orders can be obtained from the KTR homepage under www.ktr.com.

Please note protection mark ISO 16016.	Drawn: 15.08.13 Kb/Koh	Replaced for: KTR-N valid from 30.06.10
	Verified: 23.08.13 Kb	Replaced by: