

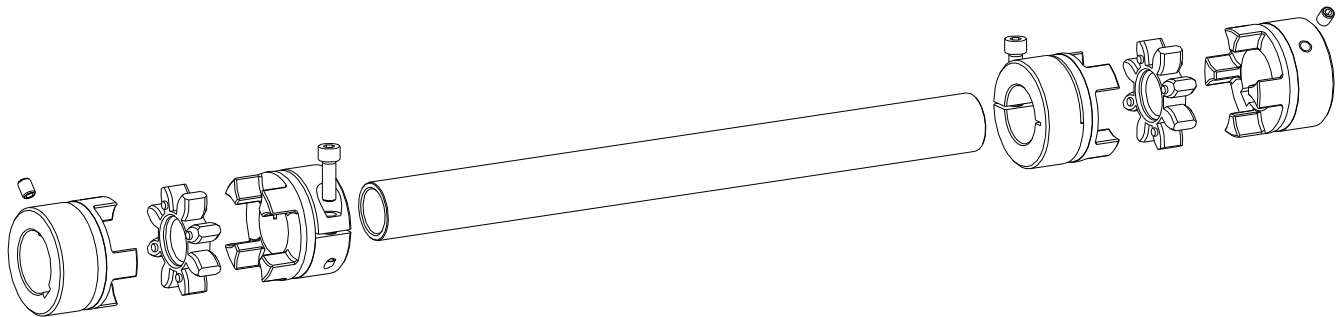

These mounting instructions are a summary of KTR-N 45510 comprising details about the assembly/disassembly of the intermediate shaft coupling ROTEX® GS ZR1 and ZR2 only. Please refer to the instructions KTR-N 45510 for general advice as well as advice on safety and danger before starting up the coupling. According to EU standard (2014/34/EU), legal claims for warranty cannot be allowed.

ROTEX® GS

Torsionally flexible intermediate shaft coupling type ZR1 and ZR2



ROTEX® GS, ZR1

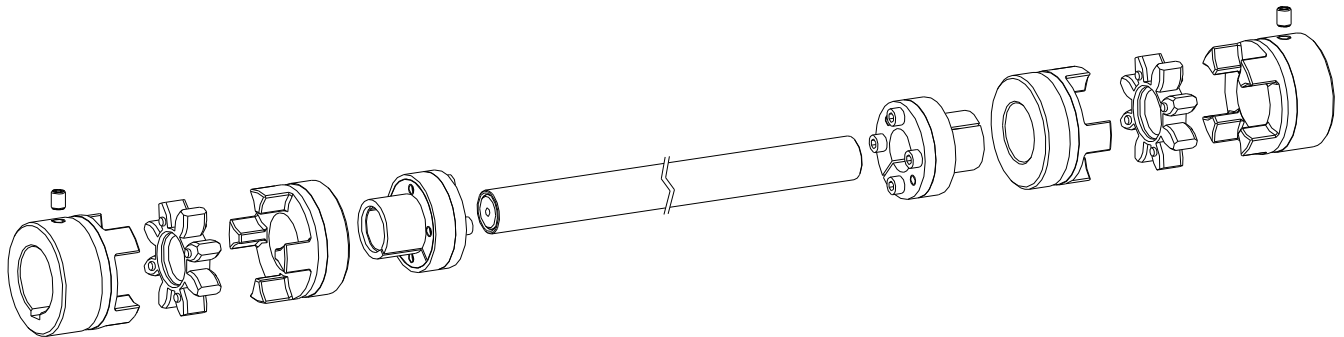

ROTEX® GS, ZR2

Table of contents

1	Technical data	2
2	Assembly	3
2.1	Components of the couplings	4
2.2	Assembly of type ZR1	5
2.3	Assembly of type ZR2	5
2.4	Displacements - alignment of the couplings	6
2.5	Critical whirling speed	8



1 Technical data

Intermediate shaft coupling type ZR1

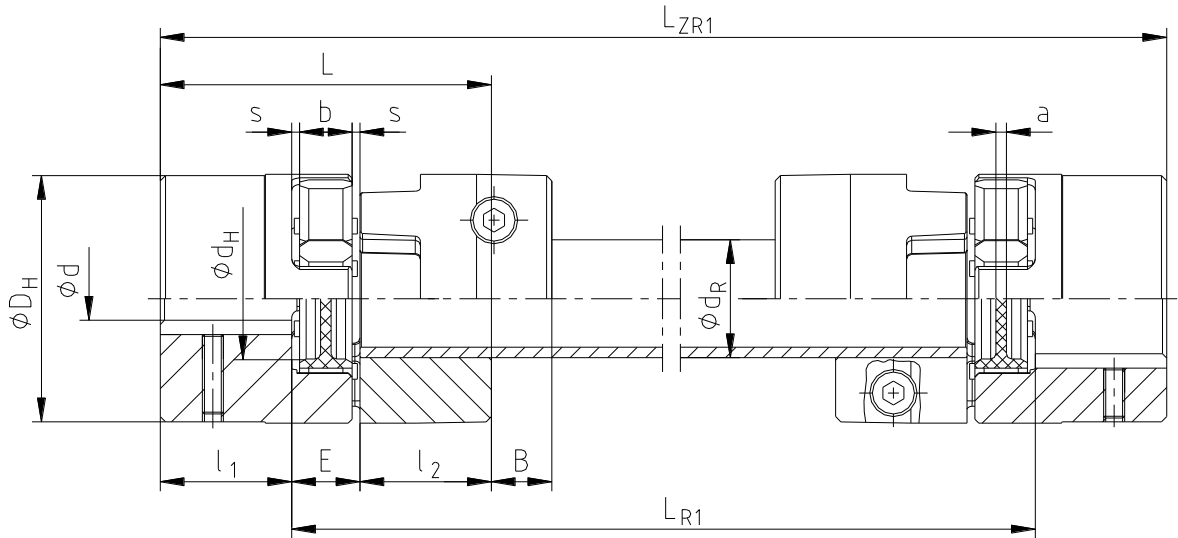

Illustration 1: ROTEX® GS, type ZR1

Table 1: Dimensions

Size	Dimensions [mm]								
	D _H	d _H	L	l ₁ ; l ₂	E	b	s	a	B
14	30	10.5	35	11	13	10	1.5	2.0	11.5
19	40	18	66	25	16	12	2.0	3.0	14.0
24	55	27	78	30	18	14	2.0	3.0	16.0
28	65	30	90	35	20	15	2.5	4.0	17.5
38	80	38	114	45	24	18	3.0	4.0	21.0

Size	Dimensions [mm] intermediate pipe			Cap screw DIN EN ISO 4762 8.8	Tightening torque [Nm]	Friction torque [Nm]
	d _R	L _{R1}	L _{ZR1}			
14	14x2.5	According to customer specification	L _{R1} +22	M3x12	1.34	6.1
19	20x3.0		L _{R1} +50	M6x16	10.5	34
24	25x2.5		L _{R1} +60	M6x20	10.5	45
28	35x4.0		L _{R1} +70	M8x25	25	105
38	40x4.0		L _{R1} +90	M8x30	25	123

Table 2: Torques and finish bores

Size	Spider ¹⁾ (component 2) Rated torque [Nm]				Unbo- red	Finish bore [mm] hub design			
	92 Sh A-GS	98 Sh A-GS	64 Sh D-GS	72 Sh D-GS		d _{min.}	1.0 d _{max.}	1.1, 1.2 d _{max.}	2.0, 2.1 d _{max.}
14	7.5	12.5	16.0	-	-	5	15	16	16
							1.0, 1.1 d _{max.}	2.5 d _{max.}	2.6 d _{max.}
19	12	21	26	-	x	6	24	24	24
24	35	60	75	97 ²⁾	x	8	28	28	28
28	95	160	200	260 ²⁾	x	10	38	38	38
38	190	325	405	525 ²⁾	x	12	45	45	45
42	265	450	560	728 ²⁾	x	14	55	50	45
48	310	525	655	852 ²⁾	x	15	62	55	55
55	410	685	825	1072 ²⁾	x	20	74	68	68
65	-	940 ³⁾	1175	-	x	22	80	70	70

1) Maximum torque of the coupling T_{Kmax.} = rated torque of the coupling T_{K rated} x 2; **except for clamping hubs types 2.0, 2.5**

2) When using the spider 72 Sh D, we recommend to use hubs made of steel.

3) Figures for spider 95 Sh A-GS

Please observe protection note ISO 16016.	Drawn:	02.01.17 Shg/Rt	Replaced for:	KTR-N dated 08.09.2014
	Verified:	02.01.17 Shg	Replaced by:	



1 Technical data

Intermediate shaft coupling type ZR2

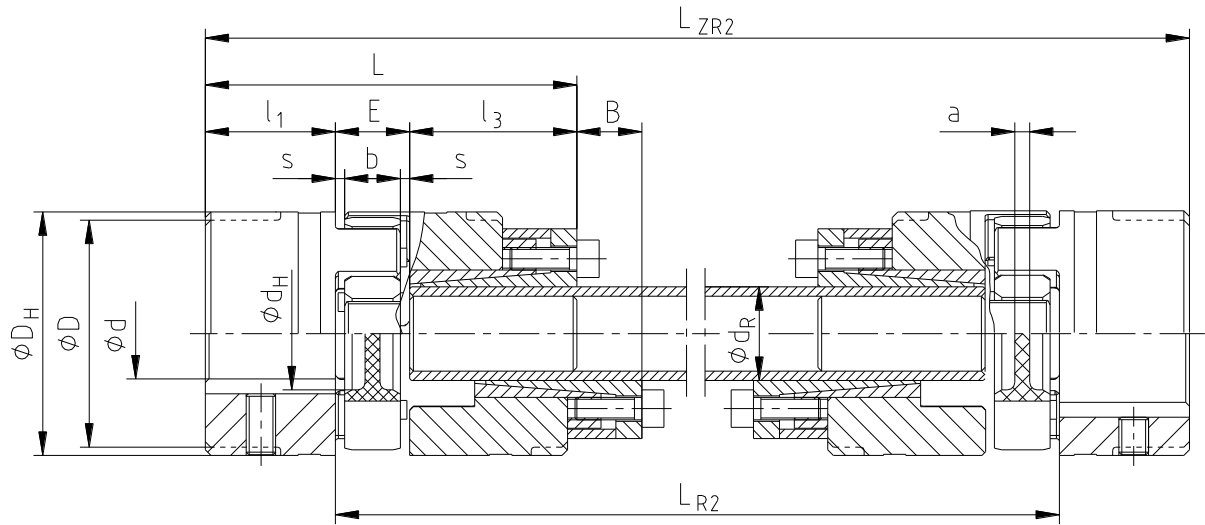

Illustration 2: ROTEX® GS, type ZR2

Table 3: Dimensions

Size	Dimensions [mm]									
	D _H	D	d _H	L	l ₁ ; l ₂	E	b	s	a	B
14	30	–	10.5	35	11	13	10	1.5	2.0	11.5
19	40	–	18	66	25	16	12	2.0	3.0	14.0
24	55	–	27	78	30	18	14	2.0	3.0	16.0
28	65	–	30	90	35	20	15	2.5	4.0	17.5
38	80	–	38	114	45	24	18	3.0	4.0	21.0
42	95	85	46	126	50	26	20	3.0	4.0	23.0
48	105	95	51	140	56	28	21	3.5	4.0	24.5
55	120	110	60	160	65	30	22	4.0	4.5	26.0
65	135	115	68	185	75	35	26	4.5	4.5	30.5

Size	Dimensions [mm] intermediate pipe			Clamping set KTR 250			
	d _R	L _{R2}	L _{ZR2}	Size dxD	Cap screw DIN EN ISO 4762 12.9	Tightening torque [Nm]	Friction torque [Nm]
14	10x2.0	According to customer specification	L _{R2} +22	10x16	M4x10	5.2	46
19	12x2.0		L _{R2} +50	12x18	M4x10	5.2	55
24	20x3.0		L _{R2} +60	20x28	M6x18	17	222
28	25x2.5		L _{R2} +70	25x34	M6x18	17	277
38	32x3.5		L _{R2} +90	32x43	M6x18	17	689
42	40x4.0		L _{R2} +100	40x53	M6x18	17	886
48	45x4.0		L _{R2} +112	45x59	M8x22	41	1842
55	55x4.0		L _{R2} +130	55x71	M8x22	41	2815
65	60x4.0		L _{R2} +150	60x77	M8x22	41	3070

2 Assembly

The coupling is generally supplied in individual parts. Before starting with the assembly, please inspect the coupling for completeness and dimensional accuracy.



With vertical assembly of the intermediate shaft couplings a special distance washer of KTR has to be inserted between the coupling hub at the bottom and the spider at the bottom.

Please observe protection note ISO 16016.	Drawn:	02.01.17 Shg/Rt	Replaced for:	KTR-N dated 08.09.2014
	Verified:	02.01.17 Shg	Replaced by:	



2 Assembly

2.1 Components of the couplings

Components of ROTEX® GS, intermediate shaft coupling type ZR1

Component	Quantity	Description
1	2	Hub (design 1.0, 1.1, 1.2, 2.0, 2.1, 2.5, 2.6, 2.8, 2.9, 6.0, 6.0 steel or 6.0 light)
2	2	Spider
3		Setscrew DIN EN ISO 4029 (for hub design 1.0 or 1.1) Cap screw DIN EN ISO 4762 (for hub design 2.0, 2.1, 2.5, 2.6, 2.8, 2.9, 6.0, 6.0 steel or 6.0 light)
4	1	Intermediate pipe
5	2	ZR clamping hub
6	2	Cap screw DIN EN ISO 4762

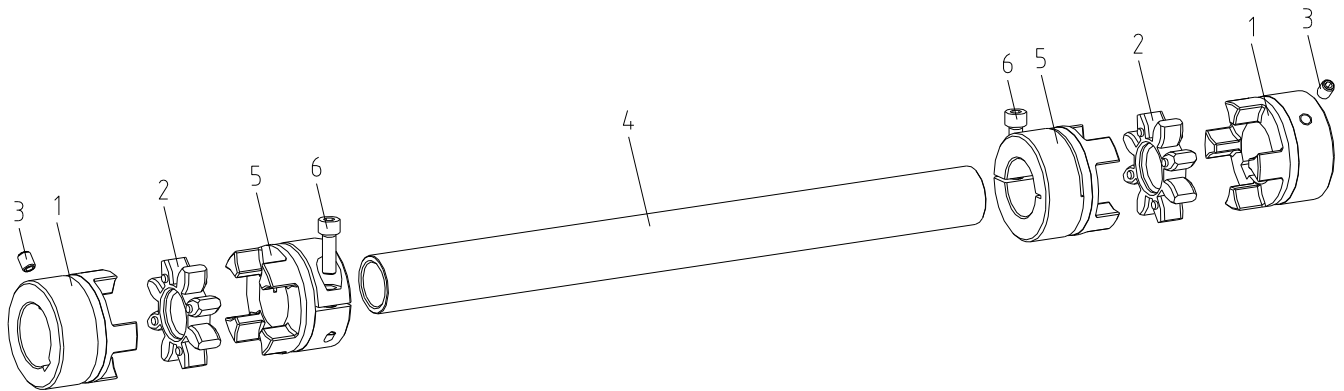

Illustration 3: ROTEX® GS ZR1, size 14 - 38

Components of ROTEX® GS, intermediate shaft coupling type ZR2

Component	Quantity	Description
1	2	Hub (design 1.0, 1.1, 1.2, 2.0, 2.1, 2.5, 2.6, 2.8, 2.9, 6.0, 6.0 steel or 6.0 light)
2	2	Spider
3		Setscrew DIN EN ISO 4029 (for hub design 1.0 or 1.1) Cap screw DIN EN ISO 4762 (for hub design 2.0, 2.1, 2.5, 2.6, 2.8, 2.9, 6.0, 6.0 steel or 6.0 light)
4	1	Intermediate shaft or intermediate pipe with spigot
5	2	Hub type 4.2
6	2	CLAMPEX® KTR 250

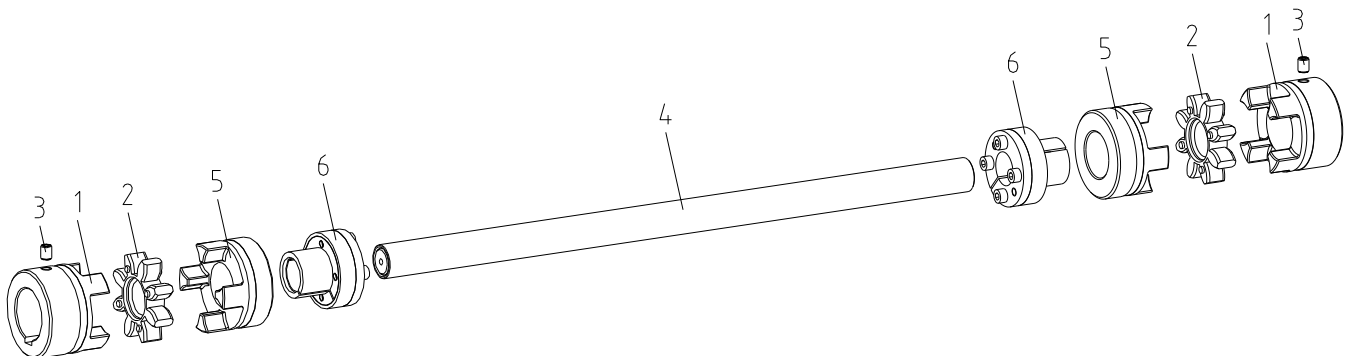

Illustration 4: ROTEX® GS ZR2, size 14 - 65

Please observe protection note ISO 16016.	Drawn: 02.01.17 Shg/Rt	Replaced for: KTR-N dated 08.09.2014
	Verified: 02.01.17 Shg	Replaced by:

**2 Assembly****2.2 Assembly of type ZR1**

- Mount the hubs on the shaft of driving and driven side. For hints regarding assembly of the hubs please refer to KTR-N 45510. The dimension between the cam ground and the cam ground of the hubs should correspond to the shaft distance dimension L_{R1} .
- Insert the spiders into the hubs.
- Shift the ZR clamping hubs onto the intermediate pipe in a way that the jaws do not protrude over the pipe. Here the jaws of the two ZR clamping hubs should be flush. If necessary, the outside diameter of the pipe should be remachined.
- Insert the intermediate pipe along with the ZR clamping hubs between the driving and driven side and consequently between the hubs with the spiders (see illustration 5).
- The distance dimension E (table 1) can be set by shifting the ZR clamping hubs axially on the pipe (see illustration 6).
- Fasten the ZR clamping hubs on the pipe by tightening the cap screws DIN EN ISO 4762 at the tightening torques T_A specified in table 1.
- Fasten the hubs by tightening the setscrews DIN EN ISO 4029 at the tightening torques T_A mentioned in KTR-N 45510.

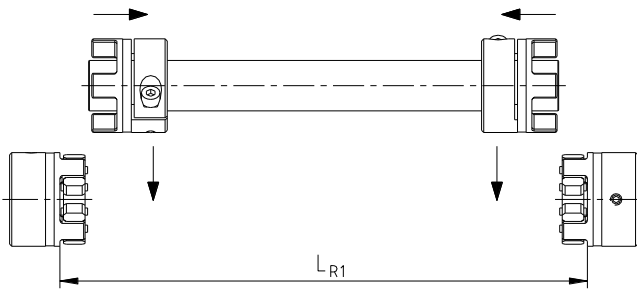

Illustration 5: Assembly of type ZR1

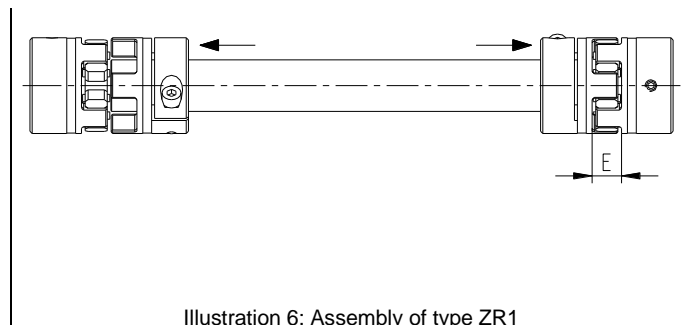

Illustration 6: Assembly of type ZR1

2.3 Assembly of type ZR2

- Mount the hubs on the shaft of driving and driven side. For hints regarding assembly of the hubs please refer to KTR-N 45510. The dimensions between the cam ground and the cam ground of the hubs should correspond to the shaft distance dimension L_{R2} .
- Insert the spiders into the hubs.
- Insert the clamping sets KTR 250 into the hubs to match type 4.2.
- Insert the hub type 4.2 along with the clamping set KTR 250 onto the intermediate shaft in a way that the jaws do not protrude over the shaft. Here the jaws of the two hubs type 4.2 should be flush.
PLEASE NOTE: In case of a long shaft distance dimension an intermediate shaft is not concerned, but an intermediate pipe with spigot. Being pressed into the pipe, the spigots need to be flush.
- Insert the intermediate shaft between the driving and driven side and consequently between the hubs with the spiders (see illustration 7).
- The distance dimension E (table 3) can be set by shifting the hub 4.2 axially along with the clamping set (see picture 8).
- Fasten the hubs type 4.2 and the clamping set on the intermediate shaft by tightening the cap screws DIN EN ISO 4762 at the tightening torques T_A mentioned in table 3.
- Fasten the hubs by tightening the setscrews DIN EN ISO 4029 at the tightening torques T_A mentioned in KTR-N 45510.



2 Assembly

2.3 Assembly of type ZR2

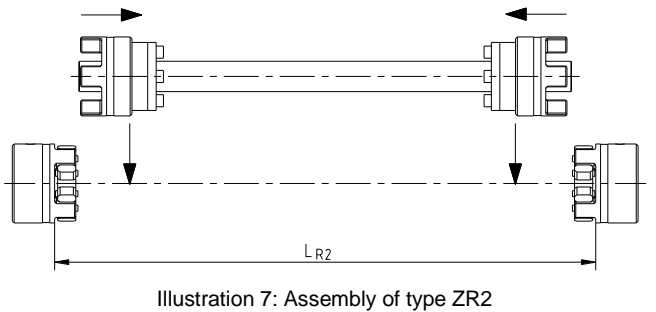

Illustration 7: Assembly of type ZR2

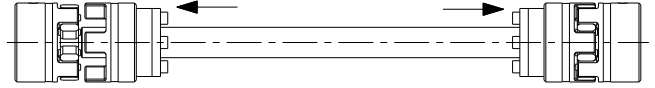

Illustration 8: Assembly of type ZR2

2.4 Displacements - alignment of the couplings

The displacement figures specified in table 4 provide for sufficient safety to compensate for external influences like, for example, thermal expansion or foundation settling.



In order to ensure a long service life of the coupling, the shaft ends have to be accurately aligned. Please absolutely observe the displacement figures specified (see table 4). If the figures are exceeded, the coupling will be damaged. The more accurate the alignment of the coupling, the longer is its service life.

Please note:

- The displacement figures specified in table 4 are maximum figures which must not arise in parallel. If radial and angular displacements arise at the same time, the permissible displacement values may only be used proportionally.
- Please inspect with a dial gauge, ruler or feeler whether the permissible displacement figures specified in table 4 can be observed.

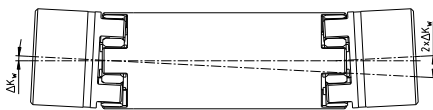

Angular displacements



Radial displacements

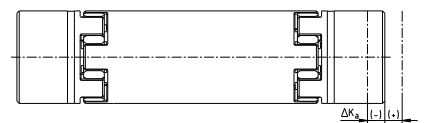

Axial displacements

$$\Delta K_r = (L_{ZR} - 2 \cdot l_1 - E) \cdot \tan \alpha$$

$$L_{max} = L + \Delta K_a$$

Illustration 9: Displacements

Please observe protection note ISO 16016.	Drawn:	02.01.17 Shg/Rt	Replaced for:	KTR-N dated 08.09.2014
	Verified:	02.01.17 Shg	Replaced by:	



2 Assembly

2.4 Displacements - alignment of the couplings

Examples of the displacement combinations specified in illustration 10:

Example 1:
 $\Delta K_r = 30\%$
 $\Delta K_w = 70\%$

Example 2:
 $\Delta K_r = 60\%$
 $\Delta K_w = 40\%$

Illustration 10:
Combinations of displacement

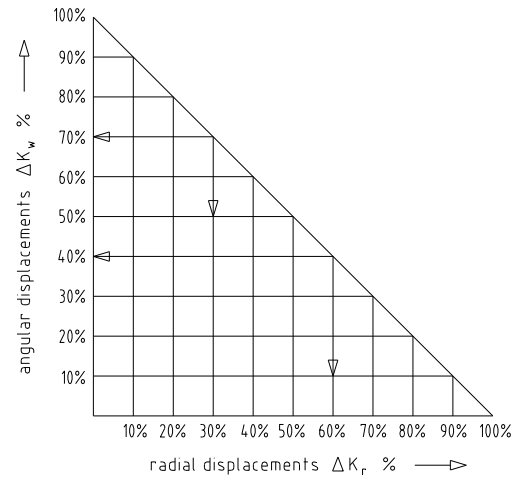

$\Delta K_{total} = \Delta K_r + \Delta K_w \leq 100 \%$

Table 4: Displacement figures – Intermediate shaft coupling

Size	Max. axial displacement ΔK_a [mm]	Max. radial displacement ΔK_r [mm] ¹⁾				Max. angular displacement ΔK_w [degree]			
		92 ShA-GS	98 ShA-GS	64 ShD-GS	72 ShD-GS	92 ShA-GS	98 ShA-GS	64 ShD-GS	72 ShD-GS
14	+1.0 / -1.0	16.8	15.2	13.5	-	1.0	0.9	0.8	-
19	+1.2 / -1.0	16.3	14.7	13.0	-	1.0	0.9	0.8	-
24	+1.4 / -1.0	16.1	14.5	12.9	11.3	1.0	0.9	0.8	0.7
28	+1.5 / -1.4	15.9	14.3	12.7	11.1	1.0	0.9	0.8	0.7
38	+1.8 / -1.4	15.5	13.9	12.4	10.8	1.0	0.9	0.8	0.7
42	+2.0 / -2.0	15.3	13.7	12.2	10.7	1.0	0.9	0.8	0.7
48	+2.1 / -2.0	15.0	13.5	12.0	10.5	1.0	0.9	0.8	0.7
55	+2.2 / -2.0	14.7	13.2	11.7	10.3	1.0	0.9	0.8	0.7
65	+2.6 / -2.0	-	12.8	11.4	-	-	0.9	0.8	-

1) Referring to an overall coupling length of $L_{ZR} = 1000$ mm.

The permissible displacement figures of the flexible ROTEX® GS couplings specified are general standard values taking into account the load of the coupling up to the rated torque T_{KN} of the coupling and an ambient temperature of + 30 °C.



2 Assembly

2.5 Critical whirling speed

Please observe the critical whirling speed of the coupling.

Illustration 11:
Critical whirling
speed of type ZR1

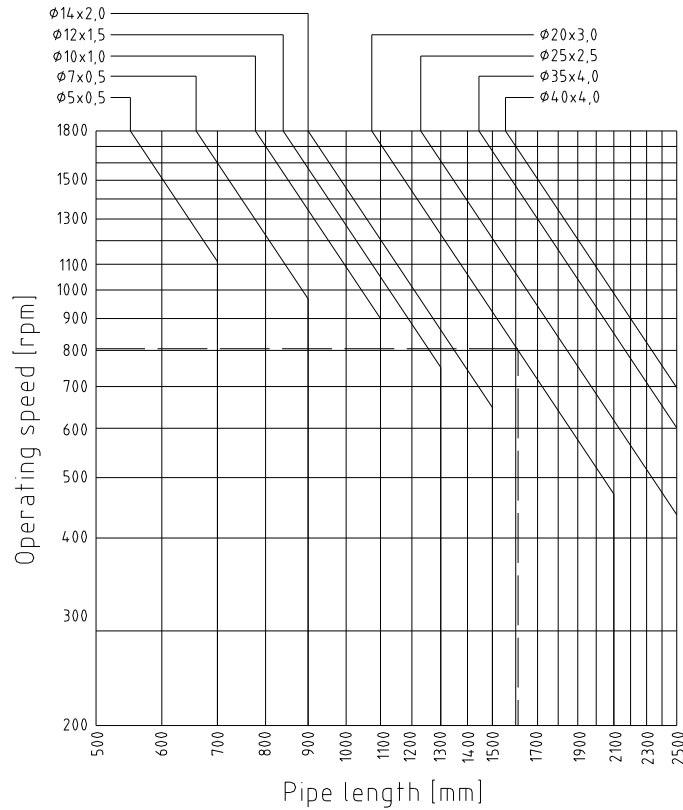

Example ZR1:
Pipe diameter Ø20x3,0
Speed 800 rpm
Max. permissible shaft distance
dimension 1600 mm

Illustration 12:
Critical whirling
speed of type ZR2

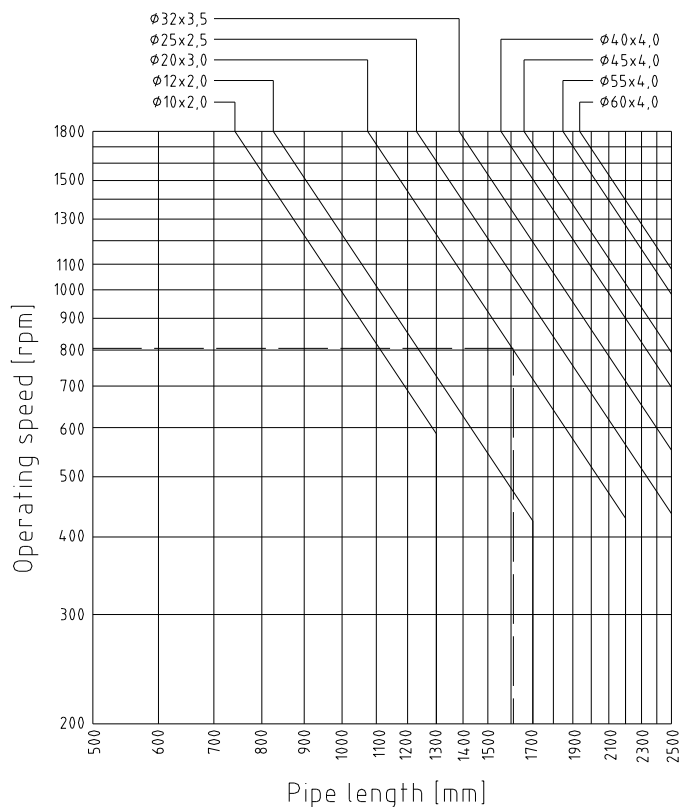

Example ZR2:
Pipe diameter Ø20x3,0
Speed 800 rpm
Max. permissible shaft distance
dimension 1600 mm