



Oil/water cooler - Type TAK/T

The oil/water coolers TAK/T are tube bundle coolers with high efficiency.

Table of contents

1	Technical data	2
2	Advice	4
2.1	General advice	4
2.2	Safety and advice symbols	4
2.3	General hazard warnings	4
2.4	Intended use	5
3	Assembly	5
3.1	Connection of oil/water cooler	5
3.2	Control	6
3.3	Pressure peaks	6
3.4	Water quality	6
4	Disposal	6
5	Cleaning	7
6	Maintenance	7
7	Spares inventory, customer service addresses	7

1 Technical data

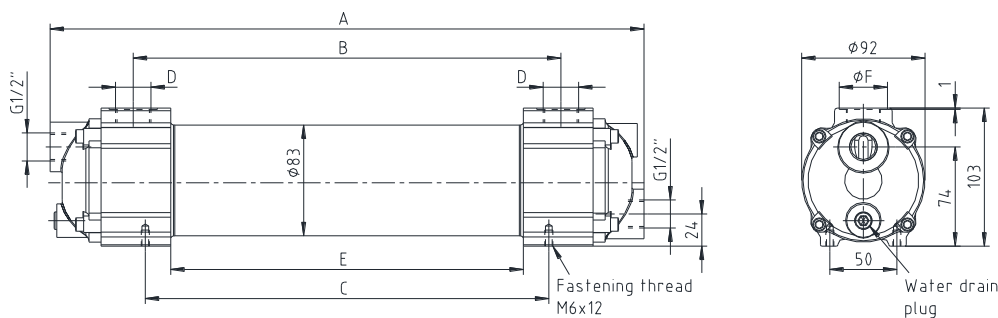

Illustration 1:
Oil/water cooler
type TAK/T series 23

Table 1: Dimensions – TAK/T series 23

Type	Dimensions [mm]						Weight [kg]	Oil capacity [l]	Water capacity [l]
	A	B	C	D [BSP]	E	ØF			
TAK/T 2312	175	59	1)	G ½	-	29.1	3	0.3	0.4
TAK/T 2322	259	135	117	G ¾	-	36	4	0.5	0.5
TAK/T 2332	345	221	203	G ¾	-	36	5	0.7	0.6
TAK/T 2342	443	319	301	G ¾	263	36	5	1.0	0.7
TAK/T 2352	571	447	429	G ¾	391	36	6	1.3	0.9
TAK/T 2362	717	587	575	G1	537	-	7	1.7	1.1
TAK/T 2372	895	765	753	G1	715	-	8	2.2	1.4

1) With model range 2310 only 2 fastening threads M6 x 12 are located centrally below the oil connections.

Max. perm. oil temperature 100 °C. Max. oil pressure 30 bar. Max. water pressure 10 bar.

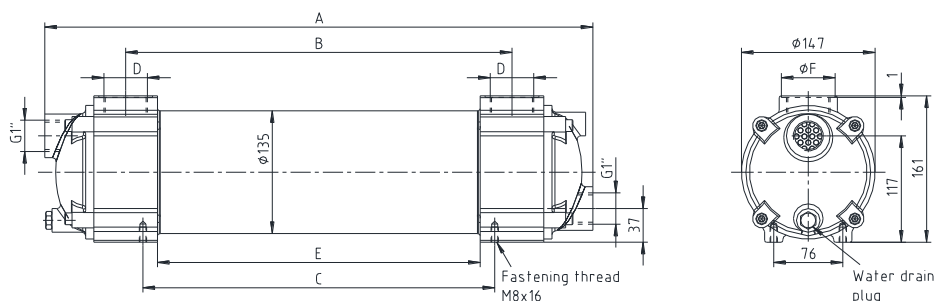

Illustration 2:
Oil/water cooler
type TAK/T series 25

Table 2: Dimensions – TAK/T series 25

Type	Dimensions [mm]						Weight [kg]	Oil capacity [l]	Water capacity [l]
	A	B	C	D [BSP]	E	ØF			
TAK/T 2512	291	129	75	G1	-	45	10	1.4	1.4
TAK/T 2522	377	199	161	G1 ¼	-	53	12	1.9	1.7
TAK/T 2532	475	297	259	G1 ¼	-	53	13	2.5	2.1
TAK/T 2542	603	425	387	G1 ¼	333	53	14	3.5	2.6
TAK/T 2552	749	571	533	G1 ½	479	59	17	4.5	3.2
TAK/T 2562	927	749	711	G1 ½	657	59	20	5.8	3.9
TAK/T 2572	1129	951	913	G1 ½	859	59	23	7.3	4.8
TAK/T 2582	1381	1203	1165	G1 ½	1111	59	27	9.0	5.8
TAK/T 2592	1727	1549	1511	G1 ½	1457	59	32	11.5	7.2

Max. perm. oil temperature 100 °C. Max. oil pressure 30 bar. Max. water pressure 10 bar.

Please observe protection note ISO 16016.	Drawn:	2017-01-02 Sho/Pz	Replacing:	KTR-N dated 2014-09-26
	Verified:	2017-01-02 Pz	Replaced by:	



1 Technical data

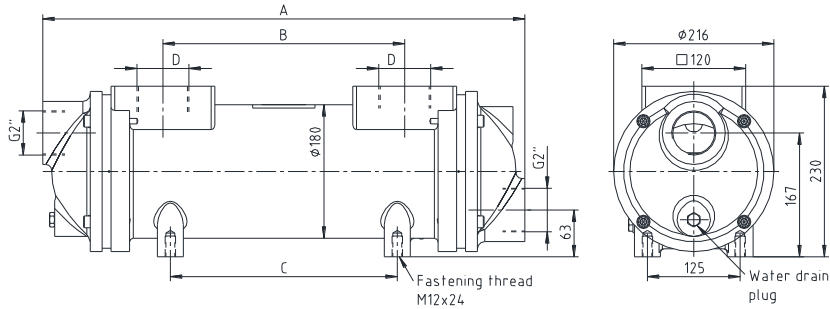

Illustration 3:
Oil/water cooler
type TAK/T series 27

Table 3: Dimensions – TAK/T series 27

Type	Dimensions [mm]				Weight [kg]	Oil capacity [l]	Water capacity [l]
	A	B	C	D [BSP]			
TAK/T 2712	650	326	306	G2	38	5.5	5.0
TAK/T 2722	796	472	452	G2	43	7.0	6.0
TAK/T 2732	974	650	630	G2	48	9.0	7.5
TAK/T 2742	1176	852	832	G2	55	11.0	9.0
TAK/T 2752	1428	1104	1084	G2	63	14.0	10.5
TAK/T 2762	1777	1453	1433	G2	74	17.5	13.0

Max. perm. oil temperature 100 °C. Max. oil pressure 20 bar. Max. water pressure 10 bar.

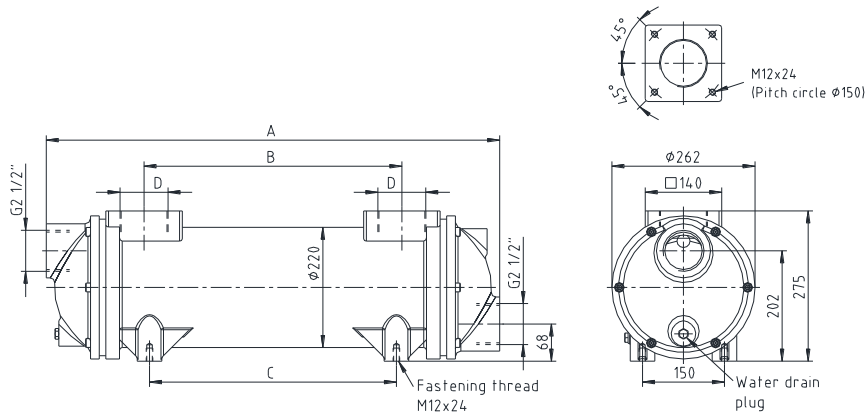

Illustration 4:
Oil/water cooler
type TAK/T series 28

Table 4: Dimensions – TAK/T series 28

Type	Dimensions [mm]				Weight [kg]	Oil capacity [l]	Water capacity [l]
	A	B	C	D [BSP]			
TAK/T 2812	684	326	306	G3	48	9.0	7.5
TAK/T 2822	830	472	452	G3	54	11.5	9.0
TAK/T 2832	1008	650	630	G3	62	15.0	10.5
TAK/T 2842	1210	852	832	G3	71	18.5	13.0
TAK/T 2852	1462	1104	1084	G3	82	23.0	15.5
TAK/T 2862	1811	1453	1433	G3	97	29.5	19.0

Max. perm. oil temperature 100 °C. Max. oil pressure 20 bar. Max. water pressure 10 bar.

Please observe protection note ISO 16016.	Drawn:	2017-01-02 Sho/Pz	Replacing:	KTR-N dated 2014-09-26
	Verified:	2017-01-02 Pz	Replaced by:	



2 Advice

2.1 General advice

Please read through these operating/assembly instructions carefully before you start up the oil/water cooler. Please pay special attention to the safety instructions!
The operating/assembly instructions are part of your product. Please store them carefully and close to the oil/water cooler. The copyright for these operating/assembly instructions remains with KTR.

2.2 Safety and advice symbols



Warning of personal injury

This symbol indicates notes which may contribute to preventing bodily injuries or serious bodily injuries that may result in death.



Warning of product damages

This symbol indicates notes which may contribute to preventing material or machine damage.



General advice

This symbol indicates notes which may contribute to preventing adverse results or conditions.



Warning of hot surfaces

This symbol indicates notes which may contribute to preventing burns with hot surfaces resulting in light to serious bodily injuries.

2.3 General hazard warnings



With assembly, operation and maintenance of the oil/water cooler it has to be made sure that the entire drive train is secured against accidental switch-on and the plant is unpressurized. You may be seriously hurt by hot or pressurized hydraulic oil or water. Please make absolutely sure to read through and observe the following safety indications.

- All operations on and with the oil/water cooler have to be performed taking into account "safety first".
- Please make sure to switch off the oil supply and water supply as well as the power pack before you perform your work on the oil/water cooler.
- Secure the power pack, oil and water supply against accidental switch-on, e. g. by providing warning signs at the place of switch-on or removing the fuse for current supply as well as the switch-on valve levers for oil and water.
- Do not reach into the operation area of the machine as long as it is in operation.
- Please secure the oil/water cooler against accidental contact (risk of burns). Please provide for the necessary protection devices and covers.

Please observe protection note ISO 16016.	Drawn: 2017-01-02 Sho/Pz	Replacing: KTR-N dated 2014-09-26
	Verified: 2017-01-02 Pz	Replaced by:



2 Advice

2.4 Intended use

You may only assemble, operate and maintain the oil/water cooler if you

- have carefully read through the operating/assembly instructions and understood them
- had technical training
- are authorized by your company

The oil/water cooler may only be used in accordance with the technical data (see chapter 1). Unauthorized modifications on the cooler are not admissible. We will not assume liability for any damage that may arise. In the interest of further development we reserve the right for technical modifications.

The **oil/water coolers TAK/T** described in here correspond to the technical status at the time of printing of these assembly/operating instructions.

3 Assembly

3.1 Connection of oil/water cooler



The pipework of the cooler has to be designed such that any external forces cannot apply on the heat exchanger.

- The oil/water cooler needs to be connected in the respective locations by means of pipework or tubes, respectively (see illustration 5 or 6).

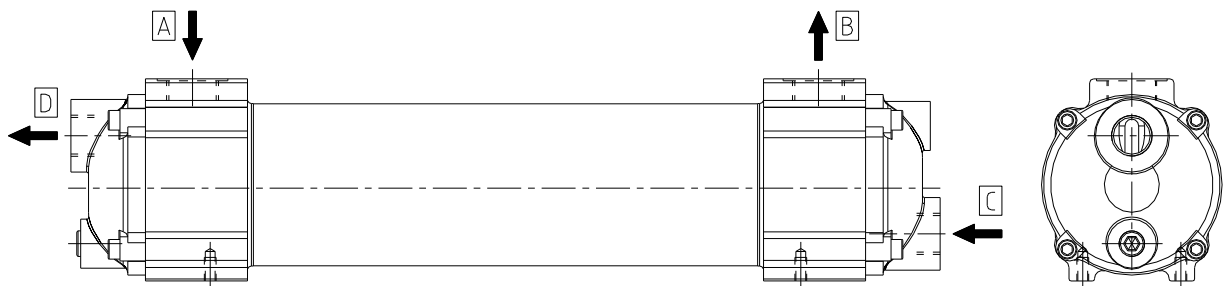

Illustration 5: Oil/water cooler type TAK/T series 23 and 25

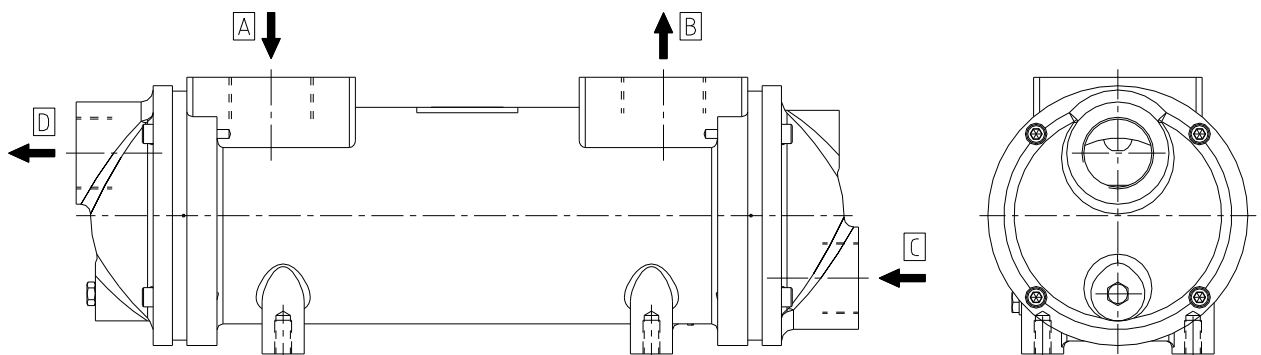

Illustration 6: Oil/water cooler type TAK/T series 27 and 28

A - medium to be cooled	C - cooling water „ON“
B - medium cooled	D - cooling water „OFF“

- Iron particles which may be generated with the assembly of pipework have to be removed. Before start-up the heat exchanger needs to be flushed carefully.

Please observe protection note ISO 16016.	Drawn: 2017-01-02 Sho/Pz	Replacing: KTR-N dated 2014-09-26
	Verified: 2017-01-02 Pz	Replaced by:

**3 Assembly****3.2 Control**

On/off control of the cooling water via magnetic valve should be preferred to proportional control.

If dirty water is controlled proportionally, floating particles are stored in the partial load range due to low water speeds causing corrosion.

If dirty cooling water is used, a dirt trap having a mesh width of about 0.5 mm has to be installed in the pipework. Dirt in the cooling water may result in plugging of the water-bearing pipes of the heat exchanger preventing sufficient cooling.

3.3 Pressure peaks

Pressure peaks in the return pipe should be avoided, since they may result in destruction of the heat exchanger.

If volume flow peaks arise, please protect the oil/water cooler by means of a fast opening bypass valve.

3.4 Water quality

Requirement 1: The water needs to be clean, i. e. without any pollutions.

Requirement 2: The content of hardness producers should be low. Higher amounts of furring reduce the thermal output of cooling systems considerably.
A light amount of furring protects the material against corrosion.

Requirement 3: The content of free carbon dioxide should correspond to zero, since such waters (rainwater, surface water) are aggressive against nonferrous heavy metals and do not produce any protective layer

Requirement 4: The water must not contain any ammonia. The chloride content should be less than 100 mg/l. River waters, sea waters and stream waters along with some well waters are excluded.
The safest way how to prevent larger amounts of furring or corrosion is to use desalinated water or condensate having the following properties:

- Carbonate hardness 4°dH
- Chloride content < 100 mg/l

4 Disposal

In respect of environmental protection we would ask you to dispose of the packaging or products on termination of their service life in accordance with the legal regulations and standards that apply, respectively.

- **Metal**
Any metal components have to be cleaned and disposed of by scrap metal.
- **Gaskets**
Gaskets can be disposed of by residual waste.
- **Nylon materials**
Nylon materials have to be collected and disposed of by a waste disposal company.



5 Cleaning

After an operating period of about half a year the condition of the inner surfaces of the pipes should be inspected. The future cleaning intervals have to be specified depending on the degree of dirt.



Before cleaning please make sure that the oil/water cooler has cooled down. Touching the heated components causes burns.

Cleaning is effected either chemically or by means of brushes with nylon handle, do not use any wire brushes. A residual layer of furring is welcome.

6 Maintenance

Preventive maintenance operations have to be performed by the user regularly.

The maintenance intervals mainly depend on the operating period and the water speed reached. In case of frequent standstill and low water quality short maintenance intervals are necessary.

- Inspect the oil/water cooler for leakages.



Leakages have to be eliminated immediately. Oil which has escaped has to be removed properly, since oil residues may vaporize on hot components and ignite.

7 Spares inventory, customer service addresses

A basic requirement to ensure the operational readiness of the oil/water cooler is a stock of the most important spare parts on site.

Contact addresses of the KTR partners for spare parts and orders can be obtained from the KTR homepage at www.ktr.com.



KTR does not assume any liability or warranty for the use of spare parts and accessories which are not provided by KTR and for the damages which may incur as a result.

Please observe protection note ISO 16016.	Drawn: 2017-01-02 Sho/Pz	Replacing: KTR-N dated 2014-09-26
	Verified: 2017-01-02 Pz	Replaced by: