

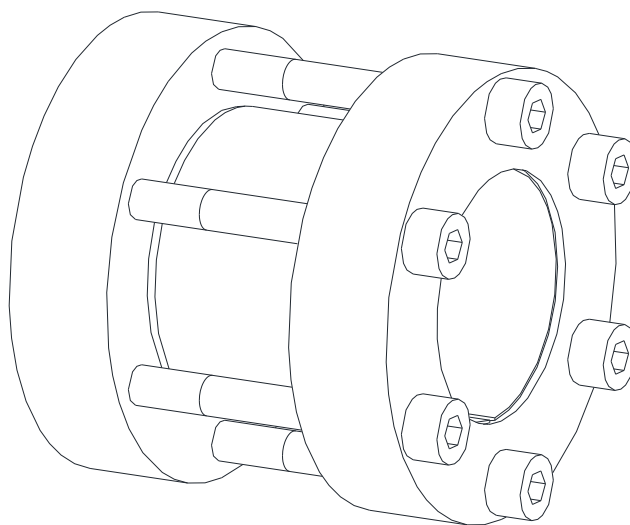

CLAMPEX® KTR 700



The **CLAMPEX® clamping set** is a frictionally engaged, detachable shaft-to-shaft connection for cylindrical shafts without feather key.

Table of contents

1	Technical data	2
2	Advice	3
2.1	General advice	3
2.2	Safety and advice symbols	3
2.3	General hazard warnings	3
2.4	Intended use	4
3	Storage, transport and packaging	4
3.1	Storage	4
3.2	Transport and packaging	4
4	Assembly	4
4.1	Components of clamping set	5
4.2	Assembly of clamping set	5
4.3	Disassembly of clamping set	6
5	Disposal	6
6	Spares inventory, customer service addresses	6
7	Advice regarding the use in  potentially explosive atmospheres according to EU directive 2014/34/EU	6

1 Technical data

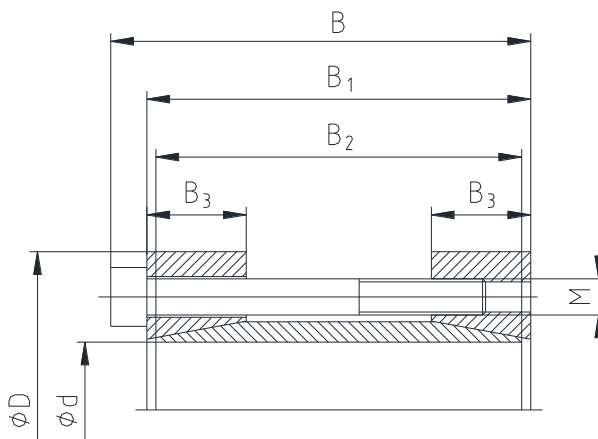

Illustration 1: CLAMPEX® KTR 700

Table 1: Technical data

Dimensions [mm]					Clamping screws DIN EN ISO 4762 – 12.9; $\mu_{total} = 0,14$				Transmittable torque or axial force		Surface pressure between shaft of clamping set P_w [N/mm ²]	Weight ~ kg
d x D	B	B ₁	B ₂	B ₃	M	Length	z quant ity	T _A [Nm]	T [Nm]	F _{ax.} [kN]		
10 x 35	42	38	36	15	M4	30	6	5.5	62	12	219	0.2
11 x 35	42	38	36	15	M4	30	6	5.5	66	12	193	0.2
12 x 35	42	38	36	15	M4	30	6	5.5	72	12	177	0.2
14 x 45	42	38	36	15	M4	30	6	5	76	11	137	0.2
15 x 45	56	50	47	15	M6	45	4	17	160	21	252	0.4
16 x 45	56	50	47	15	M6	45	4	17	170	21	235	0.4
17 x 45	56	50	47	15	M6	45	4	17	180	21	220	0.4
18 x 50	56	50	47	15	M6	45	4	17	190	21	207	0.5
19 x 50	56	50	47	15	M6	45	4	17	200	21	196	0.4
20 x 50	56	50	47	15	M6	45	4	17	220	22	195	0.4
22 x 55	66	60	57	18	M6	55	6	17	360	33	219	0.5
24 x 55	66	60	57	18	M6	55	6	17	390	33	200	0.6
25 x 55	66	60	57	18	M6	55	6	17	400	32	189	0.6
28 x 60	66	60	57	18	M6	55	6	17	390	28	147	0.8
30 x 60	66	60	57	18	M6	55	6	17	420	28	138	0.7
32 x 75	83	75	72	20	M8	70	4	41	610	38	158	0.1
35 x 75	83	75	72	20	M8	70	4	41	670	38	145	1.3
38 x 75	83	75	72	20	M8	70	4	41	730	38	134	1.2
40 x 75	83	75	72	20	M8	70	4	41	760	38	126	1.2
42 x 85	93	85	81	22	M8	80	6	41	1170	56	160	1.8
45 x 85	93	85	81	22	M8	80	6	41	1260	56	150	1.7
48 x 90	93	85	81	22	M8	80	6	41	1360	57	142	1.9
50 x 90	93	85	81	22	M8	80	6	41	1400	56	135	1.8
55 x 95	93	85	81	22	M8	80	8	41	2000	73	159	2.0
60 x 100	93	85	81	22	M8	80	8	41	2260	75	151	2.2
65 x 105	93	85	81	22	M8	80	8	41	2500	77	143	2.6
70 x 115	110	100	96	35	M10	80	8	83	3300	94	102	4.1
75 x 120	110	100	96	35	M10	80	8	83	3500	93	94	4.3
80 x 125	110	100	96	35	M10	80	7	75	3900	98	92	4.5
90 x 136	110	100	96	35	M10	80	8	75	5100	113	95	5.2
100 x 158	132	120	116	40	M12	100	8	130	8350	167	111	6.0

1 Technical data

Tolerances

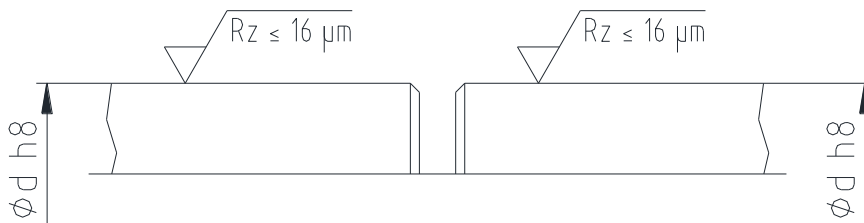

Illustration 3: Tolerances and surfaces (example: CLAMPEX® KTR 700)

- 1) One proper turning process is sufficient ($Rz \leq 16 \mu\text{m}$).
- 2) Maximum permissible tolerance of both shafts

2 Advice

2.1 General advice

Please read through these operating/assembly instructions carefully before you mount the clamping set. Please pay special attention to the safety instructions!
 The operating/assembly instructions are part of your product. Please store them carefully and close to the clamping set.
 The copyright for these operating/assembly instructions remains with KTR.

2.2 Safety and advice symbols



Warning of potentially explosive atmospheres

This symbol indicates notes which may contribute to preventing bodily injuries or serious bodily injuries that may result in death caused by explosion.



Warning of personal injury

This symbol indicates notes which may contribute to preventing bodily injuries or serious bodily injuries that may result in death.



Warning of product damages

This symbol indicates notes which may contribute to preventing material or machine damage.



General advice

This symbol indicates notes which may contribute to preventing adverse results or conditions.

2.3 General hazard warnings



With assembly and disassembly of the clamping set it has to be made sure that the entire drive train is secured against accidental switch-on. You may be seriously hurt by rotating parts. Please make absolutely sure to read through and observe the following safety indications.

- All operations on and with the clamping set have to be performed taking into account "safety first".
- Please make sure to switch off the power pack before you perform your work on the clamping set.
 Secure the power pack against accidental switch-on, e. g. by providing warning signs at the place of switch-on or removing the fuse for current supply.
- Do not reach into the operation area of the machine as long as it is in operation.
- Please secure the rotating drive components against accidental contact. Please provide for the necessary protection devices and covers.

Please observe protection note ISO 16016.	Drawn: 2017-01-04 Shg/Jh	Replacing: KTR-N dated 2004-12-08
	Verified: 2017-01-10 Shg	Replaced by:



2 Advice

2.4 Intended use

You may only assemble and disassemble the clamping set if you

- have carefully read through the operating/assembly instructions and understood them
- had technical training
- are authorized by your company

The clamping set may only be used in accordance with the technical data (see table 1). Unauthorized modifications on the clamping set are not admissible. We will not assume liability for any damage that may arise. In the interest of further development we reserve the right for technical modifications.

The clamping set described in here corresponds to the technical status at the time of printing of these operating/assembly instructions.

3 Storage, transport and packaging

3.1 Storage

The clamping sets are supplied in preserved condition and can be stored at a dry and covered place for 6 - 9 months.



**Humid storage rooms are not suitable.
Please make sure that condensation is not generated.**

3.2 Transport and packaging



In order to avoid any injuries and any kind of damage please always make use of proper transport and lifting equipment.

The clamping sets are packed differently each depending on size, quantity and kind of transport. Unless otherwise contractually agreed, packaging will follow the in-house packaging specifications of KTR.

4 Assembly

Generally the clamping set is supplied in mounted condition. Before assembly the clamping set has to be inspected for completeness.

Please observe protection note ISO 16016.	Drawn: 2017-01-04 Shg/Jh	Replacing: KTR-N dated 2004-12-08
	Verified: 2017-01-10 Shg	Replaced by:



4 Assembly

4.1 Components of clamping set

Components of clamping set CLAMPEX® KTR 700

Component	Quantity	Description
1	1	Front external ring (with through holes)
2	1	Inner ring (slit)
3	1	Rear external ring (with tapped holes)
4	see table 1	Cap screws DIN EN ISO 4762

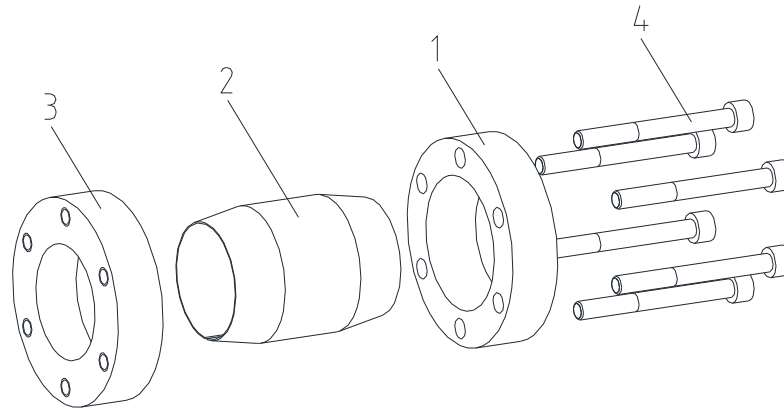

Illustration 2: CLAMPEX® KTR 700



Dirty or used clamping sets have to be disassembled and cleaned before assembly. Afterwards apply thin fluid oil lightly (e. g. Ballistol Universal oil or Klüber Quietsch-Ex).

4.2 Assembly of clamping set

- Please inspect the shaft fit for the tolerance specified (h8).
- Please clean and degrease the contact surfaces of the shafts to be combined. Afterwards apply thin fluid oil lightly (e. g. Ballistol Universal oil or Klüber Quietsch-Ex).



Oils and greases with molybdenum disulphide or high-pressure additives, additives of Teflon and silicone as well as internal lubricants reducing the coefficient of friction significantly must not be used. When mounting the tapers of the clamping set free from oil the tabular and calculated parameters deviate.

- Unscrew the clamping screws (do not fully unscrew) and fit the clamping set KTR 700 spec. (rigid shaft coupling) on the shaft ends to be connected.
- Lightly tighten the clamping screws manually and align clamping set and shafts (see illustration 3).

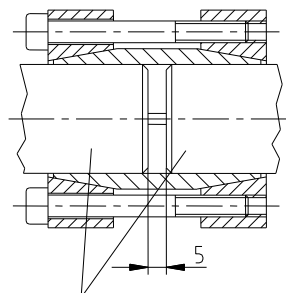

Shaft ends must be flush with each other.

Illustration 3: Alignment of clamping set

Please observe protection note ISO 16016.	Drawn:	2017-01-04 Shg/Jh	Replacing:	KTR-N dated 2004-12-08
	Verified:	2017-01-10 Shg	Replaced by:	

**4 Assembly****4.2 Assembly of clamping set**

- Tighten the clamping screws evenly crosswise step by step to the tightening torque specified in table 1. The process needs to be repeated until the tightening torque has been achieved with all screws.

4.3 Disassembly of clamping set

**Driving components released or falling down may cause injury to persons or damage on the machine.
Secure the driving components before disassembly.**

- Unscrew the clamping screws evenly one after another. Do not fully unscrew the clamping screws out of the thread.
- The clamping sets are not self-locking. If the front and rear external taper ring cannot be released, the process of releasing should be initiated by putting some pressure on the front and rear external taper ring in several positions on the circumference.
- Pull the shaft ends out of the clamping set KTR 700.



If these hints are not observed or operating conditions are not taken into account with the selection of the clamping set, the operation of the clamping set may be affected.

5 Disposal

In respect of environmental protection we would ask you to dispose of the packaging or products on termination of their service life in accordance with the legal regulations and standards that apply, respectively.
All clamping sets consist of metal. Any metal components have to be cleaned and disposed of by scrap metal.

6 Spares inventory, customer service addresses

A basic requirement to ensure the readiness for use of the drive components is a stock of some clamping sets on site.

Contact addresses of the KTR partners for spare parts and orders can be obtained from the KTR homepage at www.ktr.com.



KTR does not assume any liability or warranty for the use of spare parts and accessories which are not provided by KTR and for the damages which may incur as a result.

7 Advice regarding the use in  potentially explosive atmospheres according to EU directive 2014/34/EU

If used in potentially explosive atmospheres, the type and size of clamping set (for category 3 only) has to be selected such that the difference between the peak torque of the machine including all operating parameters and the rated torque of the clamping hub at least corresponds to a safety factor of $s = 2$.

CLAMPEX® clamping sets are not part of EU directive 2014/34/EU, since

- this product is a torsionally rigid, backlash-free, frictionally engaged connection with one or more taper clamping ring(s) by means of several screws.
(Clamping screws have to be secured, e. g. by means of a medium strength adhesive.)
- due to the design of clamping sets a fracture/failure is not likely (frictional heat is only caused by improper assembly/tightening torques, i. e. not with intended use).