

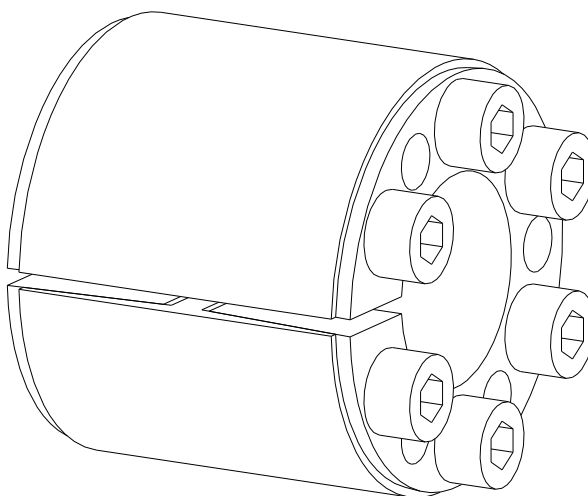

CLAMPEX® KTR 400



The **CLAMPEX® clamping set** is a frictionally engaged, detachable shaft-to-shaft connection for cylindrical shafts and bores without feather key.

Table of contents

1	Technical data	2
2	Advice	5
	2.1 General advice	5
	2.2 Safety and advice symbols	6
	2.3 General hazard warnings	6
	2.4 Intended use	6
3	Storage, transport and packaging	7
	3.1 Storage	7
	3.2 Transport and packaging	7
4	Assembly	7
	4.1 Components of clamping set	7
	4.2 Advice on clamping set	8
	4.3 Assembly of the clamping set	8
	4.4 Disassembly of clamping set	9
5	Disposal	9
6	Spares inventory, customer service addresses	10
7	Advice regarding the use in  hazardous locations according to EU directive 2014/34/EU.	10

1 Technical data

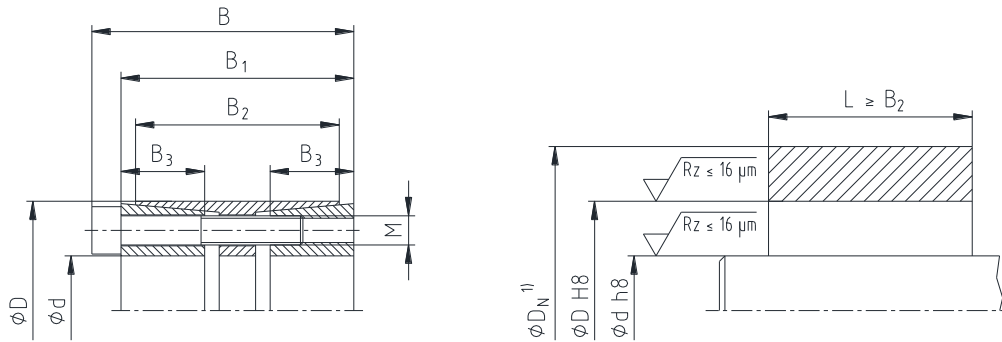

1) Dimension D_N : For calculation of hub see catalogue "Drive Technology"

Illustration 1: CLAMPEX® KTR 400

Table 1: Standard applications in industry

Dimensions [mm]					Clamping screws DIN EN ISO 4762 - 12.9 $\mu_{total} = 0.14$				Transmittable torque or axial force		Surface pressure between clamping set [N/mm ²]		Weight [-kg]
d x D	B	B1	B2	B3	M	Z Quantity	Length	$T_A^{1)}$ [Nm]	T [Nm]	F_{ax} [kN]	Shaft P_W	Hub P_N	
24 x 50	51	45	41	16	M6	6	35	17	700	58	202	92	0.5
25 x 50	51	45	41	16	M6	6	35	17	730	58	194	92	0.5
28 x 55	51	45	41	16	M6	8	35	17	1100	79	233	112	0.5
30 x 55	51	45	41	16	M6	8	35	17	1180	79	217	112	0.5
32 x 60	51	45	41	16	M6	8	35	17	1270	79	206	103	0.8
35 x 60	51	45	41	16	M6	8	35	17	1390	79	188	104	0.7
38 x 65	51	45	41	16	M6	10	35	17	1880	99	216	119	1.1
40 x 65	51	45	41	16	M6	10	35	17	1980	99	205	119	1.1
40 x 75	51	45	41	16	M8	8	35	41	2850	143	296	149	1.1
42 x 75	51	45	41	16	M8	8	35	41	3000	143	282	149	1.2
45 x 75	51	45	41	16	M8	8	35	41	3250	144	266	151	1.1
48 x 80	70	62	58	23	M8	8	55	41	3450	144	173	98	1.5
50 x 80	70	62	58	23	M8	8	55	41	3600	144	166	98	1.4
55 x 85	70	62	58	23	M8	8	55	41	3950	144	151	92	1.5
60 x 90	70	62	58	23	M8	10	55	41	5400	180	173	109	1.6
65 x 95	70	62	58	23	M8	10	55	41	5850	180	160	103	1.7
70 x 110	86	76	70	28	M10	10	60	83	10200	291	197	118	3.1
75 x 115	86	76	70	28	M10	10	60	83	10950	292	184	113	3.3
80 x 120	86	76	70	28	M10	12	60	83	14000	350	207	130	3.5
85 x 125	86	76	70	28	M10	12	60	83	15000	353	197	126	3.6
90 x 130	86	76	70	28	M10	12	60	83	15800	351	185	121	3.8
95 x 135	86	76	70	28	M10	12	60	83	16800	354	176	117	4.0
100 x 145	110	98	92	35	M12	12	80	145	26000	520	197	121	6.1
110 x 155	110	98	92	35	M12	12	80	145	28600	520	179	114	6.6
120 x 165	110	98	92	35	M12	14	80	145	36300	605	191	124	7.1
130 x 180	128	114	108	41	M14	12	90	230	46000	708	176	114	10.0
140 x 190	128	114	108	41	M14	14	90	230	57800	826	191	126	10.6
150 x 200	128	114	108	41	M14	16	90	230	70800	944	204	136	11.2
160 x 210	128	114	108	41	M14	16	90	230	75500	944	191	130	11.9
170 x 225	162	146	136	52	M16	14	110	355	95900	1128	169	114	17.6
180 x 235	162	146	136	52	M16	15	110	355	108800	1209	171	117	18.5
190 x 250	162	146	136	52	M16	16	110	355	122500	1289	173	117	21.4
200 x 260	162	146	136	52	M16	16	110	355	128900	1289	164	113	22.4
220 x 285	162	146	136	52	M16	18	110	355	171800	1562	181	120	26.6
240 x 305	162	146	136	52	M16	20	110	355	208000	1733	184	125	28.7
260 x 325	166	150	134	55	M16	21	110	355	237000	1823	169	117	31.2
280 x 355	197	177	165	66	M20	18	130	690	340000	2429	174	119	46.8
300 x 375	197	177	165	66	M20	20	130	690	405000	2700	181	125	69.7
320 x 405	197	177	165	66	M20	21	130	690	453000	2831	178	121	60.5
340 x 425	197	177	165	66	M20	22	130	690	504900	2970	176	121	63.9

1) These are the maximum screw tightening torques. They can be reduced by a maximum of 40 % of the figures specified, with T, F_{ax} , P_W and P_N declining proportionally.

1 Technical data

Page 2 continued:

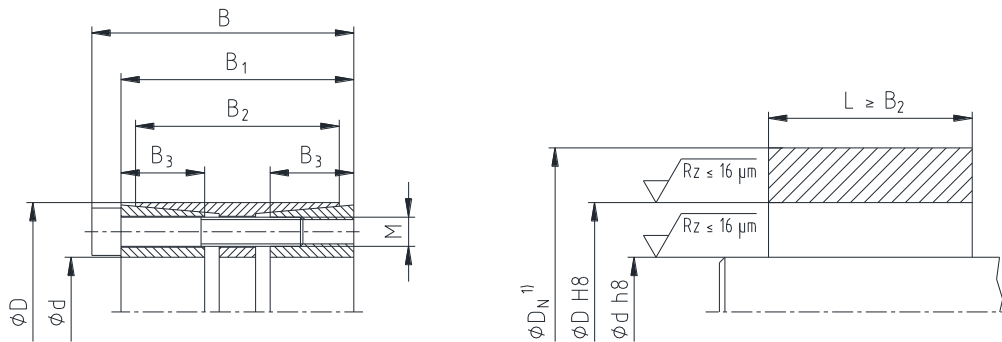

1) Dimension D_N : For calculation of hub see catalogue "Drive Technology"

Illustration 1: CLAMPEX® KTR 400

Table 1: Standard applications in industry

Dimensions [mm]					Clamping screws DIN EN ISO 4762 - 12.9 $\mu_{total} = 0.14$				Transmittable torque or axial force		Surface pressure between clamping set [N/mm ²]		Weight [-kg]
d x D	B	B1	B2	B3	M	Z Quantity	Length	$T_A^{1)}$ [Nm]	T [Nm]	F_{ax} [kN]	Shaft P_W	Hub P_N	
360 x 455	224	203	190	76	M22	21	150	930	626000	3478	169	115	86.8
380 x 475	224	203	190	76	M22	22	150	930	692000	3642	167	115	91.0
400 x 495	224	203	190	76	M22	24	150	930	795000	3975	173	121	95.3
420 x 515	224	203	190	76	M22	24	150	930	835000	3976	165	116	100
440 x 535	224	203	190	76	M22	24	150	930	875000	3977	158	112	105
460 x 555	224	203	190	76	M22	24	150	930	914000	3974	151	108	109
480 x 575	224	203	190	76	M22	28	150	930	1113000	4638	169	121	114
500 x 595	224	203	190	76	M22	28	150	930	1160000	4640	162	117	119
520 x 615	224	203	190	76	M22	30	150	930	1292000	4969	167	122	122.5
540 x 635	224	203	190	76	M22	30	150	930	1342000	4970	161	118	128
560 x 655	224	203	190	76	M22	32	150	930	1484000	5300	165	122	131
580 x 675	224	203	190	76	M22	32	150	930	1537000	5300	159	118	136
600 x 695	224	203	190	76	M22	33	150	930	1640000	5467	159	118	139

1) These are the maximum screw tightening torques. They can be reduced by a maximum of 40 % of the figures specified, with T, F_{ax} , P_W and P_N declining proportionally.

1 Technical data

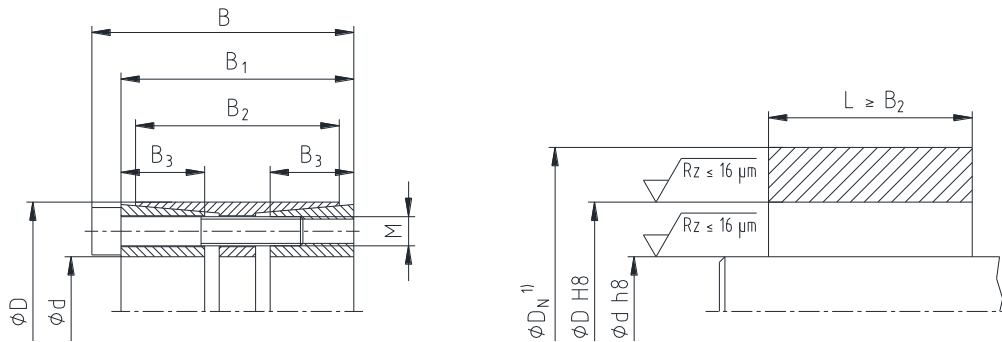

1) Dimension DN: For calculation of hub see catalogue "Drive Technology"

Illustration 1: CLAMPEX® KTR 400

Table 2: Applications with components subject to bending load and torsional stress

Dimensions [mm]					Clamping screws DIN EN ISO 4762 - 12.9 $\mu_{total} = 0.14$				Transmittable torque or axial force			Transmittable bending torque		Surface pressure between clamping set [N/mm ²]		Weight [-kg]
d x D	B	B1	B2	B3	M	z Quantity	Length	T _A [Nm]	T [Nm]	F _{ax} [kN]	Mb _{perm.} [Nm]	Shaft P _w	Hub P _N			
24 x 50	51	45	41	16	M6	6	35	14	460	38	420	230	93	0.5		
25 x 50	51	45	41	16	M6	6	35	14	470	38	430	222	94	0.5		
28 x 55	51	45	41	16	M6	8	35	14	740	53	490	257	110	0.5		
30 x 55	51	45	41	16	M6	8	35	14	790	53	520	243	112	0.5		
32 x 60	51	45	41	16	M6	8	35	14	830	52	560	230	104	0.8		
35 x 60	51	45	41	16	M6	8	35	14	890	51	610	214	106	0.7		
38 x 65	51	45	41	16	M6	10	35	14	1250	66	660	240	119	1.1		
40 x 65	51	45	41	16	M6	10	35	14	1300	65	700	230	120	1.1		
40 x 75	51	45	41	16	M8	8	35	35	2030	102	700	320	142	1.1		
42 x 75	51	45	41	16	M8	8	35	35	2120	101	730	307	142	1.2		
45 x 75	51	45	41	16	M8	8	35	35	2260	100	780	289	145	1.1		
48 x 80	70	62	58	23	M8	8	55	35	2160	90	1700	202	101	1.5		
50 x 80	70	62	58	23	M8	8	55	35	2220	89	1770	196	102	1.4		
55 x 85	70	62	58	23	M8	8	55	35	2350	85	1950	182	98	1.5		
60 x 90	70	62	58	23	M8	10	55	35	3380	113	2130	202	113	1.6		
65 x 95	70	62	58	23	M8	10	55	35	3560	110	2310	190	109	1.7		
70 x 110	86	76	70	28	M10	10	60	69	6620	189	3650	222	120	3.1		
75 x 115	86	76	70	28	M10	10	60	69	6970	186	3920	210	117	3.3		
80 x 120	86	76	70	28	M10	12	60	69	9210	230	4180	231	131	3.5		
85 x 125	86	76	70	28	M10	12	60	69	9710	228	4440	220	129	3.6		
90 x 130	86	76	70	28	M10	12	60	69	10000	222	4700	210	124	3.8		
95 x 135	86	76	70	28	M10	12	60	69	10500	221	4960	201	122	4.0		
100 x 145	110	98	92	35	M12	12	80	120	16850	337	8580	219	124	6.1		
110 x 155	110	98	92	35	M12	12	80	120	18000	327	9440	203	118	6.6		
120 x 165	110	98	92	35	M12	14	80	120	23350	389	10300	214	128	7.1		
130 x 180	128	114	108	41	M14	12	90	190	29950	461	15300	201	119	10.0		
140 x 190	128	114	108	41	M14	14	90	190	37200	531	16500	214	129	10.6		
150 x 200	128	114	108	41	M14	16	90	190	46400	619	17700	226	139	11.2		
160 x 210	128	114	108	41	M14	16	90	190	48600	608	18800	214	133	11.9		
170 x 225	162	146	136	52	M16	14	110	295	59100	695	32000	196	119	17.6		
180 x 235	162	146	136	52	M16	15	110	295	67500	750	33900	198	122	18.5		
190 x 250	162	146	136	52	M16	16	110	295	76100	801	35800	199	122	21.4		
200 x 260	162	146	136	52	M16	16	110	295	78600	786	37700	192	118	22.4		
220 x 285	162	146	136	52	M16	18	110	295	105000	955	41400	195	126	26.6		
240 x 305	162	146	136	52	M16	20	110	295	128000	1067	45200	198	130	28.7		
260 x 325	166	150	134	55	M16	21	110	295	142000	1092	51000	187	123	31.2		
280 x 355	197	177	165	66	M20	18	130	580	208000	1486	81300	192	125	46.8		
300 x 375	197	177	165	66	M20	20	130	580	252000	1680	87100	198	130	69.7		
320 x 405	197	177	165	66	M20	21	130	580	280000	1750	92900	196	127	60.5		
340 x 425	197	177	165	66	M20	22	130	580	311000	1829	98700	193	127	63.9		

1 Technical data

Page 4 continued:

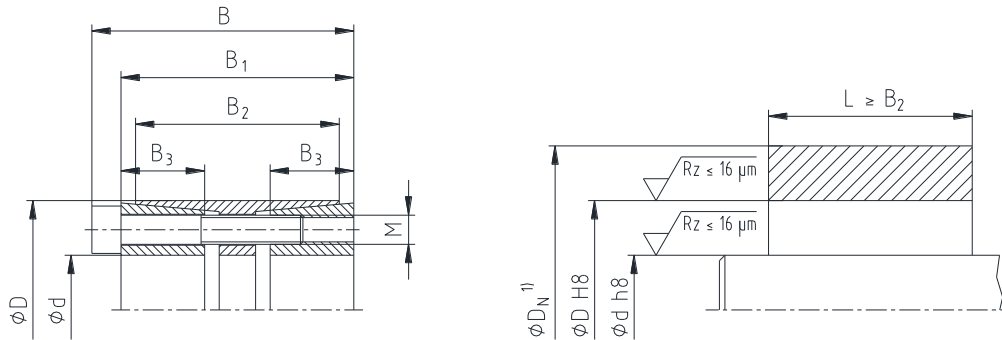

1) Dimension D_N : For calculation of hub see catalogue "Drive Technology"

Illustration 1: CLAMPEX® KTR 400

Table 2: Applications with components subject to bending load and torsional stress

Dimensions [mm]					Clamping screws DIN EN ISO 4762 - 12.9 $\mu_{total} = 0.14$				Transmittable torque or axial force		Transmittable bending torque $M_{bperm.}$ [Nm]	Surface pressure between clamping set [N/mm ²]		Weight [-kg]
d x D	B	B1	B2	B3	M	Z Quantity	Length	T_A [Nm]	T [Nm]	F_{ax} [kN]		Shaft P_W	Hub P_N	
360 x 455	224	203	190	76	M22	21	150	780	381000	2117	138500	189	121	86.8
380 x 475	224	203	190	76	M22	22	150	780	420000	2211	146000	188	122	91.0
400 x 495	224	203	190	76	M22	24	150	780	489000	2445	154000	194	127	95.3
420 x 515	224	203	190	76	M22	24	150	780	505000	2405	161500	186	123	100
440 x 535	224	203	190	76	M22	24	150	780	517000	2350	169000	178	120	105
460 x 555	224	203	190	76	M22	24	150	780	530000	2304	177000	172	117	109
480 x 575	224	203	190	76	M22	28	150	780	678000	2825	184500	189	128	114
500 x 595	224	203	190	76	M22	28	150	780	692000	2768	192000	182	125	119
520 x 615	224	203	190	76	M22	30	150	780	780000	3000	200000	186	129	122.5
540 x 635	224	203	190	76	M22	30	150	780	799000	2959	207500	180	126	128
560 x 655	224	203	190	76	M22	32	150	780	893000	3189	215500	184	129	131
580 x 675	224	203	190	76	M22	32	150	780	912000	3145	223000	179	127	136
600 x 695	224	203	190	76	M22	33	150	780	972000	3240	231000	179	127	139

Tolerances, surfaces

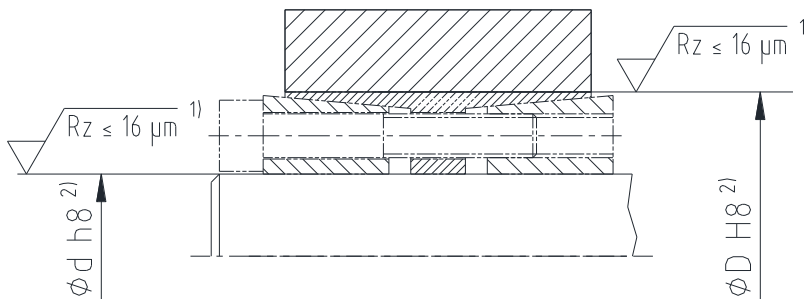

Illustration 2: Tolerances and surfaces

- 1) One proper turning process is sufficient ($R_z \leq 16 \mu\text{m}$).
- 2) Highest permissible tolerance of the hub or shaft.

2 Advice

2.1 General advice

Please read through these operating/assembly instructions carefully before you mount the clamping set. Please pay special attention to the safety instructions!
The operating/assembly instructions are part of your product. Please store them carefully and close to the clamping set. The copyright for these operating/assembly instructions remains with KTR.

Please observe protection note ISO 16016.	Drawn: 2016-07-21 Pz	Replacing: KTR-N dated 2015-09-16
	Verified: 2016-07-26 Pz	Replaced by:

**2 Advice****2.2 Safety and advice symbols****Warning of potentially explosive atmospheres**

This symbol indicates notes which may contribute to preventing bodily injuries or serious bodily injuries that may result in death caused by explosion.

**Warning of personal injury**

This symbol indicates notes which may contribute to preventing bodily injuries or serious bodily injuries that may result in death.

**Warning of product damages**

This symbol indicates notes which may contribute to preventing material or machine damage.

**General advice**

This symbol indicates notes which may contribute to preventing adverse results or conditions.

2.3 General hazard warnings**With assembly and disassembly of the clamping set it has to be made sure that the entire drive train is secured against accidental switch-on. You may be seriously hurt by rotating parts. Please make absolutely sure to read through and observe the following safety indications.**

- All operations on and with the clamping set have to be performed taking into account "safety first".
- Please make sure to switch off the power pack before you perform your work on the clamping set.
- Secure the power pack against accidental switch-on, e. g. by providing warning signs at the place of switch-on or removing the fuse for current supply.
- Do not reach into the operation area of the machine as long as it is in operation.
- Please secure the rotating drive components against accidental contact. Please provide for the necessary protection devices and covers.

2.4 Intended use

You may only assemble and disassemble the clamping set if you

- have carefully read through the operating/assembly instructions and understood them
- had technical training
- are authorized by your company

The clamping set may only be used in accordance with the technical data (see chapter 1). Unauthorized modifications on the clamping set are not admissible. We will not assume liability for any damage that may arise. In the interest of further development we reserve the right for technical modifications.

The clamping set described in here corresponds to the technical status at the time of printing of these operating/assembly instructions.



3 Storage, transport and packaging

3.1 Storage

The clamping sets are supplied in preserved condition and can be stored at a dry and roofed place for 6 - 9 months.



**Humid storage rooms are not suitable.
Please make sure that condensation is not generated.**

3.2 Transport and packaging



In order to avoid any injuries and any kind of damage please always make use of proper transport and lifting equipment.

The clamping sets are packed differently each depending on size, quantity and kind of transport. Unless otherwise contractually agreed, packaging will follow the in-house packaging specifications of KTR.

4 Assembly

Generally the clamping set is supplied in mounted condition. Before assembly the clamping set has to be inspected for completeness.

4.1 Components of clamping set

Components of clamping set CLAMPEX® KTR 400

Component	Quantity	Description
1	1	Front pressure ring (slit with tapping and through hole)
2	1	Rear pressure ring (slit with tapping)
3	1	Outer ring (slit) ¹⁾
4	see table 1 and 2	Cap screw DIN EN ISO 4762

¹⁾ Outer ring from size 420 x 515 not slit.

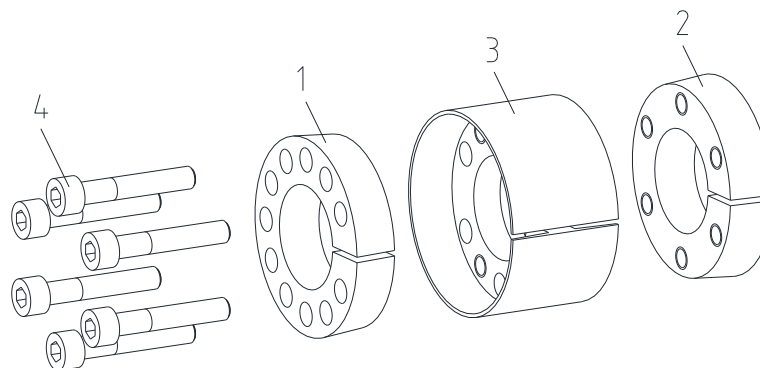

Illustration 3: CLAMPEX® KTR 400



Before assembly of the clamping set make sure that the slots of components 1, 2 and 3 are flush.

Please observe protection note ISO 16016.	Drawn:	2016-07-21 Pz	Replacing:	KTR-N dated 2015-09-16
	Verified:	2016-07-26 Pz	Replaced by:	



4 Assembly

4.2 Advice on clamping set



Provide for some space between the rear pressure ring and shaft/hub for reason of subsequent disassembly.

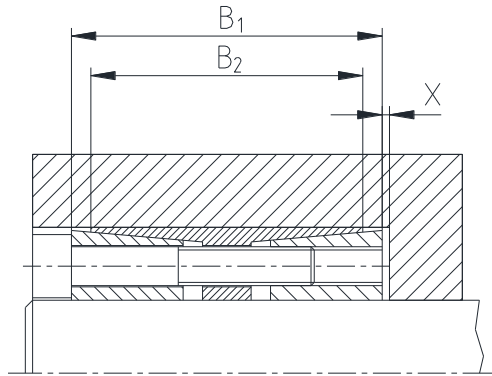

Illustration 4:
Space for
disassembly

Formula to calculate the space x for
disassembly:

$$x = \frac{(B_1 - B_2)}{2}$$

Figures for B₁ and B₂ see table 1
and 2.

4.3 Assembly of the clamping set

- Inspect the fit of shaft and hub for the tolerance specified (illustration 2).
- Clean the surfaces of the clamping set marked in illustration 5 as well as of shaft and hub and afterwards apply thin fluid oil lightly (e. g. Ballistol Universal oil or Klüber Quietsch-Ex).

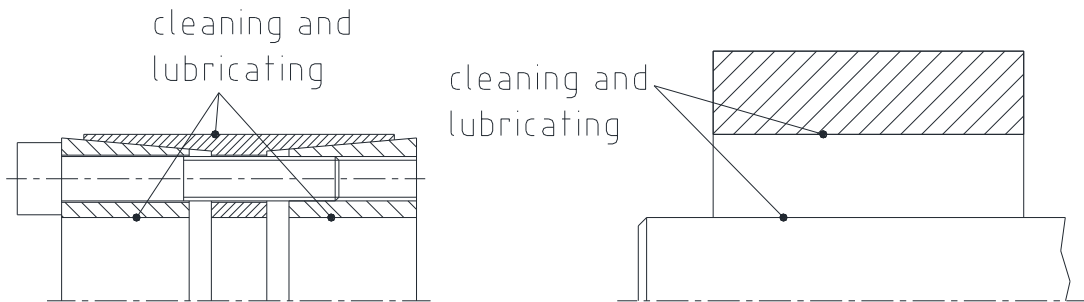

Illustration 5: Cleaning and lubricating the surfaces



Oils and greases with molybdenum disulphide or other high-pressure additives, additives of Teflon and silicone as well as internal lubricants reducing the coefficient of friction significantly must not be used. When mounting the tapers of the clamping set free from oil the tabular and calculated parameters deviate.

- Unscrew the clamping screws by several revolutions so that the pressure rings lightly detach from the external ring.
- To facilitate the assembly fasten the front and rear pressure ring by two clamping screws each via the pull-off threads (see illustration 6 and 7). Afterwards insert the clamping set KTR 400 between shaft and hub.

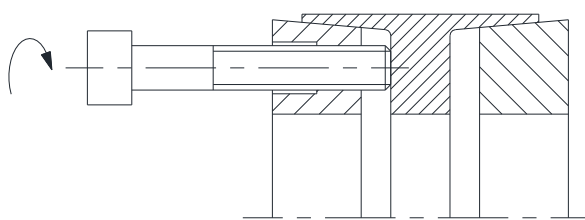

Illustration 6: Fastening the front pressure ring

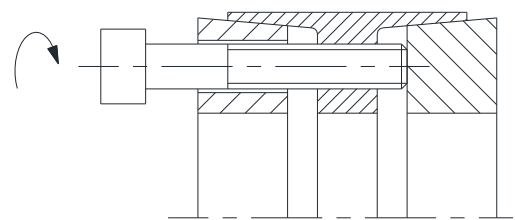

Illustration 7: Fastening the rear pressure ring

4 Assembly

4.3 Assembly of the clamping set

- Remove the pressure screws used for fastening and screw them into the thread of the rear pressure ring (component 2).
- Hand-tighten the clamping screws for the time being and align the internal clamping ring along with the hub.
- With KTR 400 make sure that the pressure rings are in parallel with one another and have an angle of 90° versus the shaft/hub.
- Tighten the clamping screws evenly crosswise step by step to the tightening torque specified in table 1 or 2. Repeat this process until all clamping screws have reached the tightening torque.



During assembly the hub is lightly displaced axially versus the shaft.

4.4 Disassembly of clamping set



**Driving components released or falling down may cause injury to persons or damage on the machine.
 Secure the driving components before disassembly.**

- Untighten and unscrew all clamping screws evenly and one after another.
- Screw the clamping screws into the pull-off threads of the front pressure ring (component 1) and the pull-off threads of the external ring (component 3) (see illustration 8 and 9).
- Tighten the clamping screws evenly crosswise. Increase the pull-off torque stepwise until the front pressure ring (component 1) and external ring (component 3) as well as the rear pressure ring (component 2) and external ring are separated.
- Take out the clamping set released between shaft and hub.

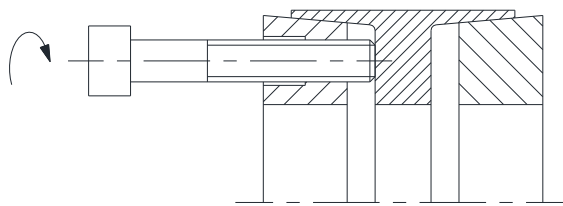

Illustration 8: Unscrewing the front pressure ring

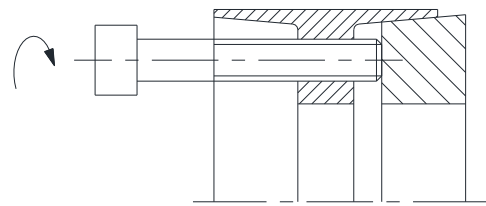

Illustration 9: Unscrewing the rear pressure ring



If these hints are not observed or operating conditions are not taken into account with the selection of the clamping set, the operation of the clamping set may be affected.



Used clamping sets have to be disassembled and cleaned before assembly. Afterwards apply thin fluid oil lightly (e. g. Ballistol Universal oil or Klüber Quietsch-Ex).

5 Disposal

In respect of environmental protection we would ask you to dispose of the packaging or products on termination of their service life in accordance with the legal regulations and standards that apply, respectively.
 All clamping sets consist of metal. Any metal components have to be cleaned and disposed of by scrap metal.



6 Spares inventory, customer service addresses

A basic requirement to ensure the operational readiness of the drive components is a stock of some clamping sets on site.

Contact addresses of the KTR partners for spare parts and orders can be obtained from the KTR homepage at www.ktr.com.



KTR does not assume any liability or warranty for the use of spare parts and accessories which are not provided by KTR and for the damages which may incur as a result.

7 Advice regarding the use in  hazardous locations according to EU directive 2014/34/EU.

If used in hazardous locations the type and size of the clamping set (for category 3 only) has to be selected such that the difference between the peak torque of the machine including all operating parameters and the rated torque of the clamping hub at least corresponds to a safety factor of $s = 2$.

CLAMPEX® clamping sets are not part of directive 2014/34/EU, since

- this product is a torsionally rigid, backlash-free, frictionally engaged connection with one or more taper clamping ring(s) by means of several screws.
(Clamping screws have to be secured, e. g. by means of a medium strength adhesive.)
- due to the design of clamping sets a fracture/failure is not likely (frictional heat is only caused by improper assembly/tightening torques, i. e. not with intended use).

Please observe protection note ISO 16016.	Drawn: 2016-07-21 Pz	Replacing: KTR-N dated 2015-09-16
	Verified: 2016-07-26 Pz	Replaced by: