

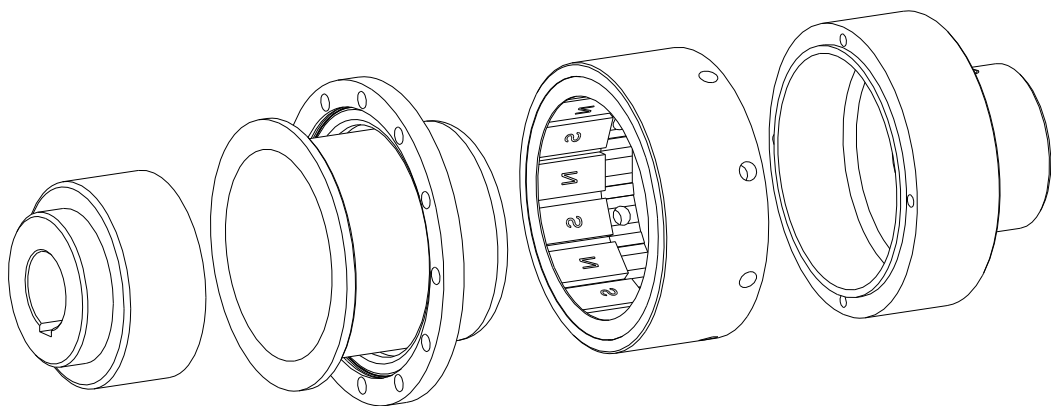

The present operating/assembly instructions exclusively apply for MINEX®-S types with carbon fibre reinforced PEEK containment shroud.

MINEX®-S Permanent-magnetic coupling with containment shroud made of PEEK CFK

according to directive 2014/34/EU



Size SA 110/16 to SE 165/24

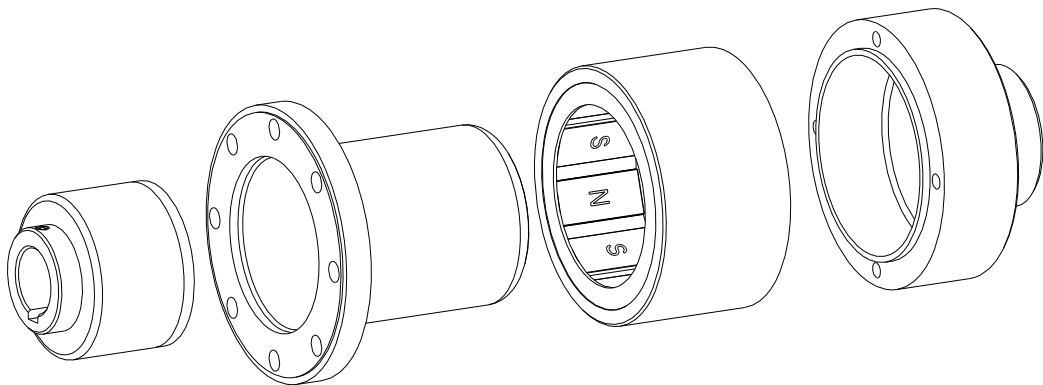





Size SA 75/10 to SC 75/10 with one-piece containment shroud

MINEX®-S is a permanent-magnetic synchronous coupling which is able to transmit torques without contact through magnetic forces. Being used in pumps and agitators, it separates the product space reliably from the atmosphere.

Please observe protection note ISO 16016.	Drawn: 2020-08-24 Pz/Wb	Replacing: KTR-N dated 2019-10-11
	Verified: 2020-09-01 Pz	Replaced by:

Table of contents

1	Technical data	3
1.1	Sizes and dimensions	3
1.2	Selection data	4
2	Advice	5
2.1	General advice	5
2.2	Safety and advice symbols	5
2.3	General hazard warnings	5
2.4	Intended use	6
2.5	Reference to EC Machinery Directive 2006/42/EC	6
2.6	Hints on couplings	7
3	Storage, transport and packaging	7
3.1	Storage	7
3.2	Transport and packaging	7
4	Assembly	8
4.1	Components of MINEX®-S	8
4.2	Advice for finish bore	9
4.3	Advice on driving and driven shaft	10
4.4	Assembly of internal and external rotor	10
4.5	Assembly of containment shroud	11
4.6	Displacements - alignment of the couplings	12
4.7	Disassembly	13
5	Start-up	13
6	Breakdowns, causes and elimination	15
7	Environment and disposal	16
7.1	Environment	16
7.2	Disposal	16
8	Maintenance and service	16
9	Spares inventory, customer service addresses	16
10	Enclosure A	
	Advice and instructions regarding the use in  potentially explosive atmospheres	17
10.1	Intended use in  potentially explosive atmospheres	17
10.2	Inspection intervals for couplings in  potentially explosive atmospheres	17
10.3	Permissible coupling materials in  potentially explosive atmospheres	17
10.4	 marking of coupling for potentially explosive atmospheres	18
10.5	Certificate of conformity	19



1 Technical data

1.1 Sizes and dimensions

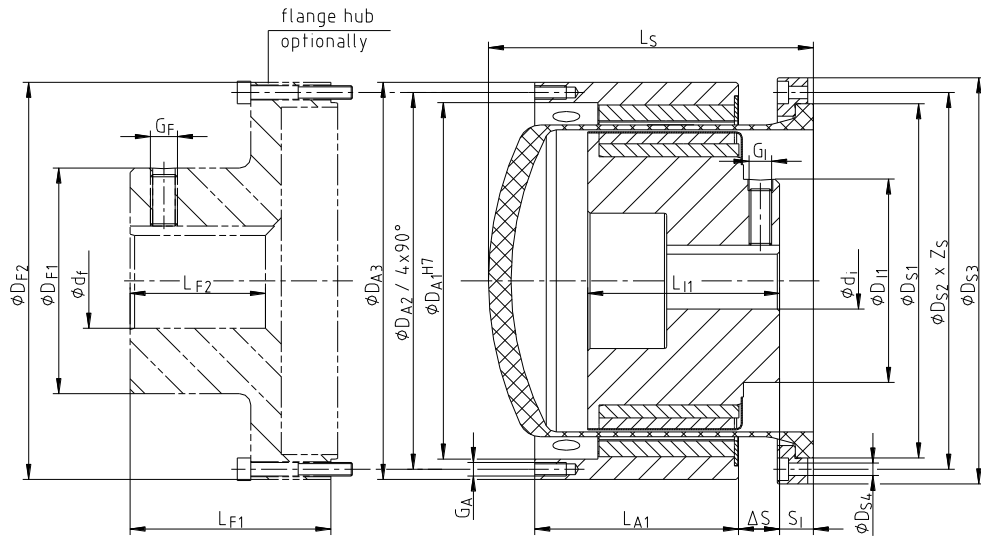

Illustration 1: MINEX®-S SA 110/16- SE 165/24

Table 1: Dimensions - SA 110/16 to SE 165/24

Size	TK max. [Nm] with -20 °C	Dimensions [mm]												
		Internal rotor							Containment shroud					
		Finish bore ¹⁾ di		Di1	Li1	Si		Gi	Ds1	Ds2	Ds3	Ds4	Zs	Ls = Ltotal ²⁾
Min.	Max.	Min.	Max.											
SA 110/16	30	14	55	80	45	4	46.0	M8	140	151	168	9.0	12	115
SB 110/16	70				65		26.0							
SC 110/16	100				85		6.0							
SB 135/20	110	20	70	90	65	4	48.0	M10	157	167	180	6.6	12	144
SC 135/20	155				85		28.0							
SD 135/20	210				110		4.0							
SC 165/24	220	24	80	110	85	4	32.0	M12	196	210	228	9.0	12	156
SD 165/24	300				110		8.0							
SE 165/24	390				130		-5							-5.0

Size	Dimensions [mm]														
	External rotor					Flange hub						General			
	DA1	DA2	DA3	GA	LA1	Finish bore df ¹⁾	DF1	DF2	LF1	LF2	GF	ΔS	Total length ³⁾		
													Min.	Max.	
SA 110/16	130	138	150	M6	41.3	55	85	153	87.5	45.5	M10	18.7	165.5	193.5	
SB 110/16					61.3								172.5	193.5	
SC 110/16					81.3								191.5	193.5	
SB 135/20	158	167	176	M6	70.3	70	100	176	89	67	M12	18.2	216	225.5	
SC 135/20					90.3								216	225.5	
SD 135/20					110.3								20.7	224	224
SC 165/24	186	195	204	M6	90.3	75	110	204	94	70	M16	18.5	231	234.8	
SD 165/24					110.3								21	231	233.3
SE 165/24					130.3								21	254.3	254.3

- 1) Bores H7 with keyway to DIN 6885 sheet 1 [JS9] and setscrew
- 2) Total length without flange hub
- 3) Total length with flange hub

Please observe protection note ISO 16016.	Drawn:	2020-08-24 Pz/Wb	Replacing:	KTR-N dated 2019-10-11
	Verified:	2020-09-01 Pz	Replaced by:	



1 Technical data

1.1 Sizes and dimensions

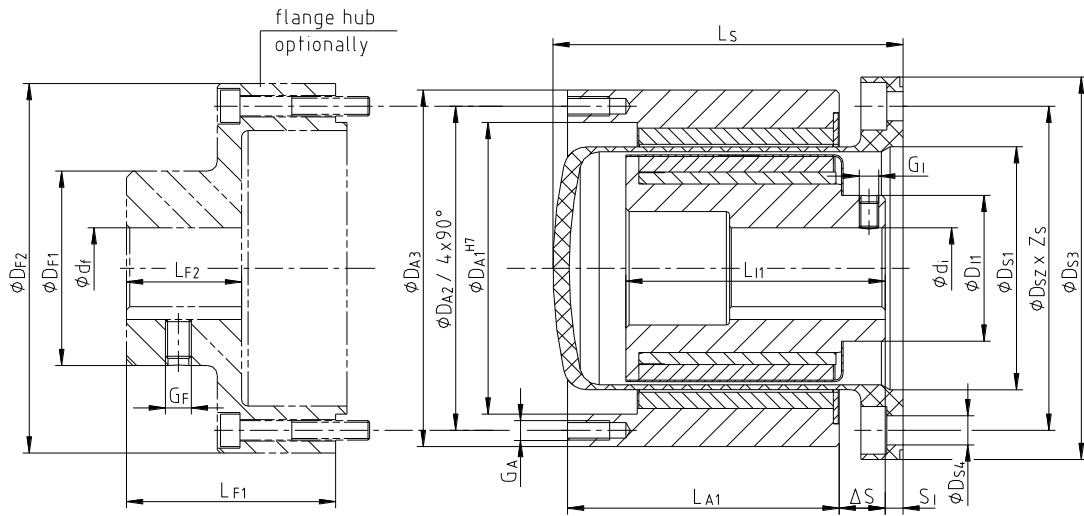

Illustration 2: MINEX®-S SA 75/10 - SC 75/10 with one-piece containment shroud

Table 2: Dimensions - SA 75/10 to SC 75/10 with one-piece containment shroud

Size	TK max. [Nm] with ~20 °C	Dimensions [mm]												
		Internal rotor						Containment shroud						
		Finish bore ¹⁾ di		D _{I1}	L _{I1}	S _I		G _I	D _{S1}	D _{S2}	D _{S3}	D _{S4}	Z _S	L _S = L _{total} ²⁾
Min.	Max.	Min.	Max.											
SA 75/10	10	12	28	45	39.5	5	54.5	M6	75	100	118	9	8	108
SB 75/10	24				58		34.5							
SC 75/10	40				80		10.0							

Size	Dimensions [mm]													
	External rotor					Flange hub					General			
	DA1	DA2	DA3	GA	LA1	Finish bore d _f ¹⁾	DF1	DF2	LF1	LF2	GF	ΔS	Total length ³⁾	
													Min.	Max.
SA 75/10	90	100	110	M6	41.3	42	60	114	64.5	35.5	M8	12.2	148.5	172.5
SB 75/10					61.3								162.5	
SC 75/10					83.8								167.5	

1) Bores H7 with keyway to DIN 6885 sheet 1 [JS9] and setscrew

2) Total length without flange hub

3) Total length with flange hub

1.2 Selection data

Table 3: Permissible operating pressure

Max. operating temperature [°C]	Max. operating pressure P _{max} [bar]	Max. speed [rpm]
130	16	3600

The materials of the magnetic coupling result from the application and are bound to the order.

Please observe protection note ISO 16016.	Drawn:	2020-08-24 Pz/Wb	Replacing:	KTR-N dated 2019-10-11
	Verified:	2020-09-01 Pz	Replaced by:	



2 Advice

2.1 General advice

Please read through these operating/assembly instructions carefully before you start up the coupling. Please pay special attention to the safety instructions!



The **MINEX®-S** coupling is suitable and approved for the use in hazardous locations. When using the coupling in potentially explosive atmospheres, observe the special advice and instructions regarding safety in enclosure A.

The operating/assembly instructions are part of your product. Please store them carefully and close to the coupling. The copyright for these operating/assembly instructions remains with KTR.

2.2 Safety and advice symbols



Warning of potentially explosive atmospheres

This symbol indicates notes which may contribute to preventing bodily injuries or serious bodily injuries that may result in death caused by explosion.



Warning of personal injury

This symbol indicates notes which may contribute to preventing bodily injuries or serious bodily injuries that may result in death.



Warning of product damages

This symbol indicates notes which may contribute to preventing material or machine damage.



General advice

This symbol indicates notes which may contribute to preventing adverse results or conditions.



Warning of hot surfaces

This symbol indicates notes which may contribute to preventing burns with hot surfaces resulting in light to serious bodily injuries.

2.3 General hazard warnings



For people with pacemakers the handling of MINEX®-S is dangerous. In this case it is compulsory to meet the following measures:

- A safety distance of 2 m must be kept towards the non-assembled components of the coupling.
- For assembled couplings with magnetic robots aligned in axial position to each other and with an ambient housing of the coupling (bellhousing) a minimum safety distance of 0.5 m applies.
A crane should be used for handling assembled drive units.

With assembly, operation and maintenance of the coupling it has to be made sure that the entire drive train is secured against accidental switch-on. You may be seriously hurt by rotating parts. Please make absolutely sure to read through and observe the following safety indications.

Please observe protection note ISO 16016.	Drawn: 2020-08-24 Pz/Wb	Replacing: KTR-N dated 2019-10-11
	Verified: 2020-09-01 Pz	Replaced by:



2 Advice

2.3 General hazard warnings



A distance of 1 m between MINEX®-S and magnetic data carriers (bank cards, disks, etc.) must be observed. The internal and the external rotor have a **strong magnetic field**. Within a distance of 0.5 m around the MINEX®-S uncontrolled handling close to metallic components, sudden mutual attraction of the rotors or magnetizable components may cause injuries or damages on the parts.

- Operations on the MINEX®-S are generally only permitted at standstill and with unpressurized condition.
- All operations on and with the coupling have to be performed taking into account "safety first".
- Please make sure to switch off the power pack before you perform your work on the coupling.
- Secure the power pack against accidental switch-on, e. g. by providing warning signs at the place of switch-on or removing the fuse for current supply.
- Do not reach into the operating area of the coupling as long as it is in operation.
- Please secure the coupling against accidental contact. Please provide for the necessary protection devices and covers.

The operator is asked to check within the scope of his safety concept as to which impacts on the environment may be associated with a failure of the magnetic coupling and which additional safety measures protecting people must be taken.

In addition to the advice given in this safety data sheet the general instructions for operational safety and accident prevention must be observed.

2.4 Intended use

You may only assemble, operate and maintain the coupling if you

- have carefully read through the operating/assembly instructions and understood them
- are technically qualified and specifically trained (e. g. safety, environment, logistics)
- are authorized by your company

The coupling may only be used in accordance with the technical data (see chapter 1). Unauthorized modifications on the coupling design are not admissible. We will not assume liability for any damage that may arise. In the interest of further development we reserve the right for technical modifications.

The **MINEX®-S** described in here corresponds to the technical status at the time of printing of these operating/assembly instructions.

2.5 Reference to EC Machinery Directive 2006/42/EC

The couplings supplied by KTR should be considered as components, not machines or partly completed machines according to EC Machinery Directive 2006/42/EC. Consequently KTR does not have to issue a declaration of incorporation. For details about safe assembly, start-up and safe operation refer to the present operating/assembly instructions considering the warnings.

Please observe protection note ISO 16016.	Drawn: 2020-08-24 Pz/Wb	Replacing: KTR-N dated 2019-10-11
	Verified: 2020-09-01 Pz	Replaced by:



2 Advice

2.6 Hints on couplings

With applications for sealing liquids we recommend circulation of the medium inside the containment shroud.
For dirty media containing abrasive or magnetic particles a separation in the circulation is recommended.

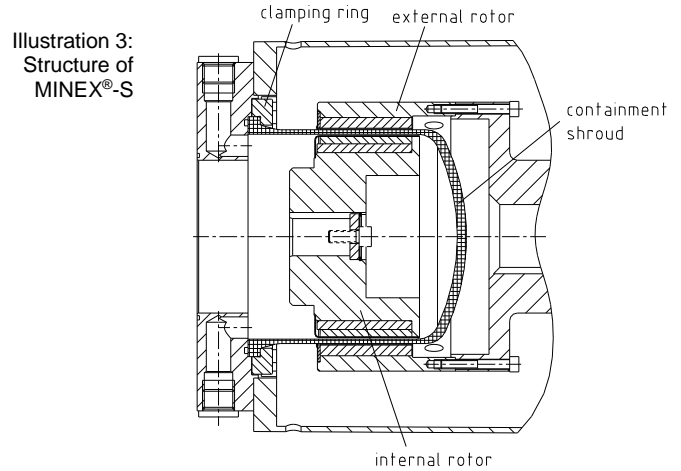

3 Storage, transport and packaging

3.1 Storage

The coupling hubs are supplied in preserved condition and can be stored at a dry and covered place for 2 years.



The storage rooms must not include any ozone-generating devices like e. g. fluorescent light sources, mercury-vapour lamps or electrical high-voltage appliances. Humid storage rooms are not suitable. Please make sure that condensation is not generated. The best relative air humidity is less than 65 %. A direct contact with metallic components must be avoided. Direct heat exposure (sun, heating) on the MINEX®-S must be avoided.

With the conservation of all units having a MINEX®-S installed, the compatibility of the preservative selected with MINEX®-S materials must be checked.

3.2 Transport and packaging



In order to avoid any injuries and any kind of damage please always make use of proper transport and lifting equipment.

The couplings are packed differently each depending on size, number and kind of transport. Unless otherwise contractually agreed, packaging will follow the in-house packaging specifications of KTR.

Please observe protection note ISO 16016.	Drawn: 2020-08-24 Pz/Wb	Replacing: KTR-N dated 2019-10-11
	Verified: 2020-09-01 Pz	Replaced by:



4 Assembly

The coupling is generally supplied in individual parts. Before assembly the coupling has to be inspected for completeness.



Please make sure that the coupling components are not damaged when being unpacked. The coupling components have a strong magnetic field.

4.1 Components of MINEX®-S

Components of the MINEX®-S, size SA 110/16 to SE 165/24

Component	Quantity	Description
1	1	External rotor
2	1	Containment shroud with clamping ring
3	1	Internal rotor
4	1	Setscrew DIN EN ISO 4029 ¹⁾
5 ²⁾	1	Flange hub with setscrew DIN EN ISO 4029 ¹⁾ and cap screws DIN EN ISO 4762 or hexagon screw DIN EN ISO 4017

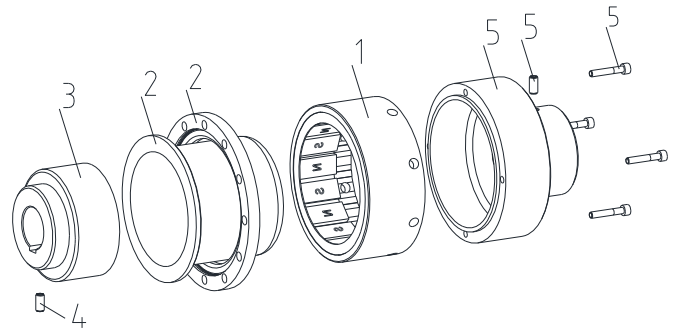

Illustration 4: MINEX®-S, size SA 110/16 to SE 165/24

- 1) with finish bored type only
- 2) only on request

Components of MINEX®-S, size SA 75/10 to SC 75/10 with one-piece containment shroud

Component	Quantity	Description
1	1	External rotor
2	1	Containment shroud
3	1	Internal rotor
4	2	Setscrew DIN EN ISO 4029 ¹⁾
5 ²⁾	1	Flange hub with setscrew DIN EN ISO 4029 ¹⁾ and cap screws DIN EN ISO 4762 or hexagon screw DIN EN ISO 4017

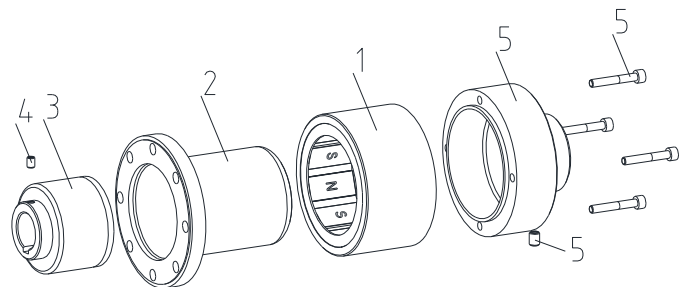

Illustration 5: MINEX®-S, size SA 75/10 to SC 75/10 with one-piece containment shroud

- 1) with finish bored type only
- 2) only on request



If KTR also supplies component 5, the following tightening torques must be considered when screwing the hub to the external rotor. The screws to be used are also part of the scope of delivery of KTR.

Table 4: Tightening torques of the cap screws or hexagon screws

Size	75/10	110/16	135/20	165/24
Cap screw acc. to DIN EN ISO 4762 ¹⁾ or hexagon screw DIN EN ISO 4017 ¹⁾	M6			
Tightening torque T _A [Nm]	14			

1) min. property class 10.9

Please observe protection note ISO 16016.	Drawn:	2020-08-24 Pz/Wb	Replacing:	KTR-N dated 2019-10-11
	Verified:	2020-09-01 Pz	Replaced by:	



4 Assembly

4.2 Advice for finish bore



The maximum permissible bore diameters d (see chapter 1 - technical data) must not be exceeded. If these figures are disregarded, the coupling may tear. Rotating particles may cause danger to life.

- Hub bores machined by the customer have to observe concentricity or axial runout, respectively (see illustration 6 and 7).
- Please make absolutely sure to observe the figures for $\varnothing d_{max}$.
- Carefully align the hubs when the finish bores are drilled.
- Please provide for a setscrew according to DIN EN ISO 4029 with a cup point or an end plate to fasten the hubs axially.

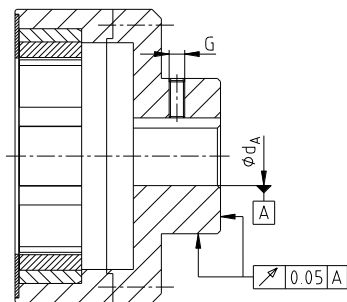

Illustration 6: Concentricity and axial runout on the flange hub

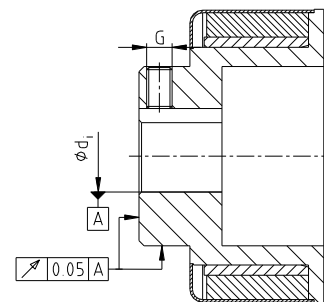

Illustration 7: Concentricity and axial runout on internal rotor



The customer bears the sole responsibility for all machining processes performed subsequently on unbored or pilot bored as well as finish machined coupling components and spare parts. KTR does not assume any warranty claims resulting from insufficient remachining.



KTR supplies unbored or pilot bored coupling components and spare parts only upon explicit request of the customer. These parts are additionally marked with the symbol Ⓢ .

Reference to unbored resp. pilot bored coupling components with explosion protection marking:

Basically the company KTR supplies couplings resp. coupling hubs with explosion protection marking as an unbored or pilot bored type only on explicit request of the customer. The prerequisite is a declaration of exemption submitted by the customer assuming any responsibility and liability for remachining performed properly.

Table 5: Setscrew DIN EN ISO 4029

Size	75/10	110/16	135/20	165/24	75/10	110/16	135/20	165/24
	Internal rotor				Flange hub ¹⁾			
Dimension G	M6	M8	M10	M12	M8	M10	M12	M12
Tightening torque T_A [Nm]	4.8	10	17	40	10	17	40	40

1) if the flange hub is supplied by KTR

Please observe protection note ISO 16016.	Drawn:	2020-08-24 Pz/Wb	Replacing:	KTR-N dated 2019-10-11
	Verified:	2020-09-01 Pz	Replaced by:	



4 Assembly

4.3 Advice on driving and driven shaft

- When manufacturing the pump shaft and the adapter plate for the containment shroud, the concentricity and the axial runout (see illustration 8) must be observed.
- If using the containment shroud with clamping ring:
Please use tolerance H7 for centering the containment shroud (see illustration 8, on the left).
- If using the one-piece containment shroud (size 75):
Please use tolerance f7 for centering the containment shroud (see illustration 8, on the right).
- Tolerance fits and surfaces for O-rings:
finely finished Rz 6.3 µm.

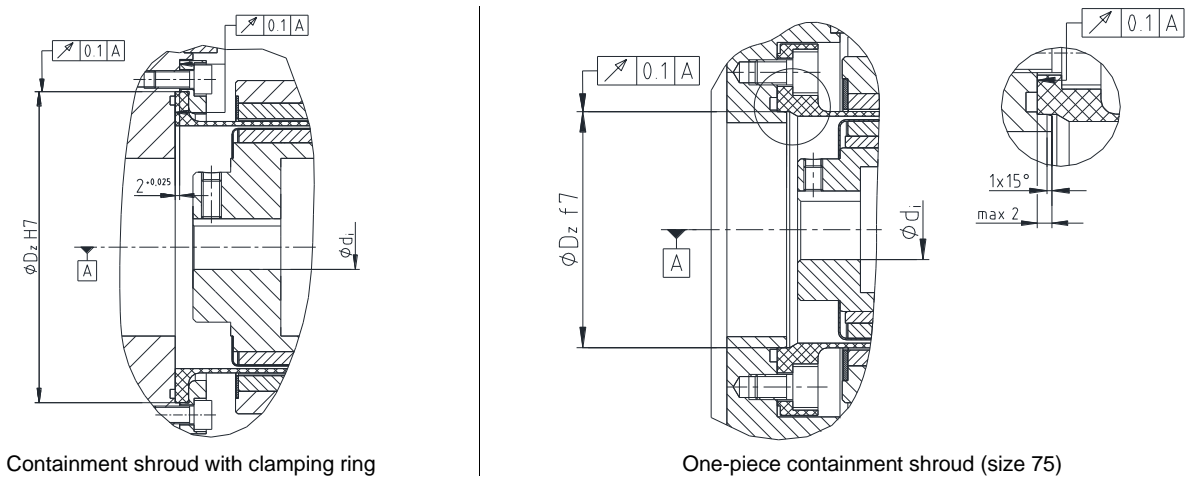

Illustration 8: Tolerances of connection components on driven side

4.4 Assembly of internal and external rotor



For the assembly we recommend to have the data sheet of the magnetic coupling available. Specifications entered in the dimensional drawing have to be primarily observed.



Impacts and shocks on the coupling components are not permissible. They may cause damages on the components.



We recommend to inspect bores, shaft, keyway and feather key for dimensional accuracy before assembly.

- Before assembly the internal and external rotor must be cleaned from magnetic dust. Recommended utilities are: Propyl alcohol and cellulose cloths (no cleaning rags).
- Screw the external rotor with the flange hub. Tighten the screws at the tightening torque specified in table 4.
- Mount the internal rotor and the external rotor on the shaft of driving and driven side.



Heating the internal rotor and the flange hub lightly (approx. 80 °C) allows for an easier mounting on the shaft.



Touching the heated hubs causes burns. Please wear safety gloves.

Please observe protection note ISO 16016.	Drawn: 2020-08-24 Pz/Wb	Replacing: KTR-N dated 2019-10-11
	Verified: 2020-09-01 Pz	Replaced by:



4 Assembly

4.4 Assembly of internal and external rotor

- Observe the distance dimension between internal rotor (Si) and sealing surface of the containment shroud specified in table 1 respectively 2.



The user must ensure correct alignment of the internal rotor and the containment shroud.

- Secure the rotors by tightening the setscrews acc. to DIN EN ISO 4029 (see table 5) or by using an end plate and end screw.

4.5 Assembly of containment shroud

- Put the O-ring or the flat seal - each depending on the design - into the adapter flange or the mounting groove of the containment shroud.



The material must be resistant to the intended operating conditions (medium, temperature).

- With use of the containment shroud with clamping ring:
Push the containment shroud over the internal rotor and center it on the adapter or pump flange. Shift the containment shroud above the internal rotor and screw it to the adaptor or pump flange via suitable screws (not included in the scope of delivery).
- With use of the one-piece containment shroud (size 75):
Shift the containment shroud above the internal rotor and screw it to the adaptor or pump flange via suitable screws (not included in the scope of delivery).



For fastening the containment shroud to the adapter or pump flange use cap screws according to table 5 and tighten at the tightening torques specified.

- Tighten the cap screws evenly crosswise gradually in several revolutions to the tightening torque specified in table 6. Repeat this process until the full tightening torque has been achieved with all cap screws.

Table 6: Tightening torques for cap screws

Size	Cap screw	Thread	z = number	T _A [Nm]
75/10	DIN EN ISO 4762 - 12.9	M8	8	12
110/16	DIN EN ISO 4762 - 12.9	M8	12	25
135/20	DIN 6912 - 10.9	M6	12	14
165/24	DIN 6912 - 10.9	M8	12	25

- The user has to ensure venting or draining of the internal space of the containment shroud himself.
- Please make sure that driving and driven side are slowly connected to prevent the external rotor from striking against the containment shroud.



There is the danger of squeezing if the magnets of internal and external rotor are tightened suddenly.

Please observe protection note ISO 16016.	Drawn: 2020-08-24 Pz/Wb	Replacing: KTR-N dated 2019-10-11
	Verified: 2020-09-01 Pz	Replaced by:



4 Assembly

4.5 Assembly of containment shroud

- Please make sure that there is a radial direction with the assembly because the external rotor must not touch the containment shroud.



Do not damage the external rotor and the containment shroud during the assembly.

- Observe the distance dimension between external rotor ($S_1 + \Delta S$) and sealing surface of the containment shroud specified in table 1 respectively 2. Hereby you ensure that the outer and the inner magnets are flush above each other.
- Fill the machine and containment shroud fully with one medium during standstill.
- Please carefully vent the containment shroud and the circulation cycle.

4.6 Displacements - alignment of the couplings

The displacement figures specified in table 7 provide for sufficient safety to compensate for external influences like, for example, thermal expansion or foundation settling.



In order to ensure a long service life of the coupling and avoid dangers with the use in potentially explosive atmospheres, the shaft ends must be accurately aligned. Please absolutely observe the displacement figures specified (see table 7). If the figures are exceeded, the coupling will be damaged.



The more accurate the alignment of the coupling, the longer is its service life. If used in potentially explosive atmospheres for explosion group IIC, only half of the displacement figures (see table 7) are permissible.

Please note:

- The displacement figures specified in table 7 are maximum figures which must not arise in parallel. If radial and angular displacements arise at the same time, the permissible displacement values may only be used proportionally (see illustration 10).
- Please inspect with a dial gauge, ruler or feeler gauge whether the permissible displacement figures of table 7 can be observed.

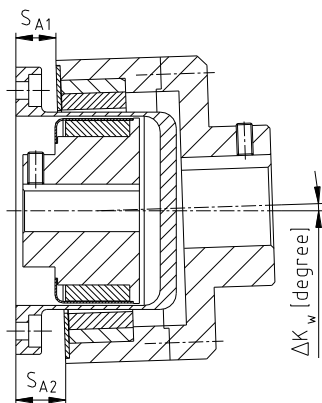

Angular displacement

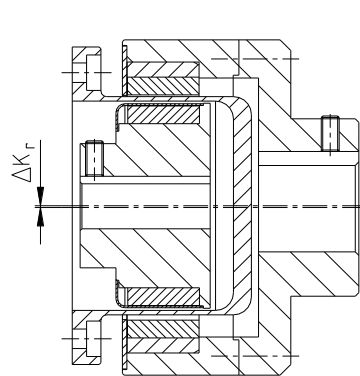

Radial displacement

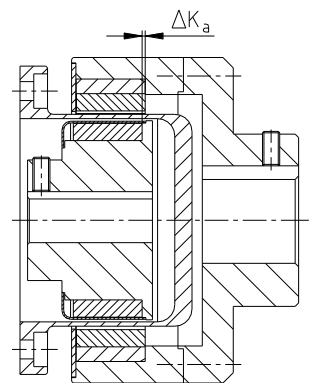

Axial displacement

$\Delta K_w = S_{A2} - S_{A1} \text{ [mm]}$

Illustration 9: Displacements

Please observe protection note ISO 16016.	Drawn: 2020-08-24 Pz/Wb	Replacing: KTR-N dated 2019-10-11
	Verified: 2020-09-01 Pz	Replaced by:



4 Assembly

4.6 Displacements - alignment of the couplings

Examples of the displacement combinations specified in illustration 10:

Example 1:
 $\Delta K_r = 30\%$
 $\Delta K_w = 70\%$

Example 2:
 $\Delta K_r = 60\%$
 $\Delta K_w = 40\%$

Illustration 10:
Combinations of displacement

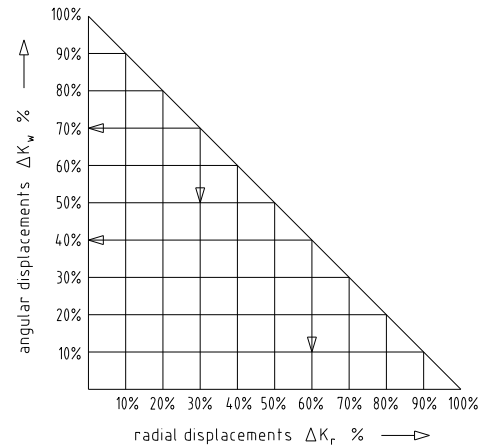

$\Delta K_{total} = \Delta K_r + \Delta K_w \leq 100\%$

Table 7: Displacement figures

Size	Max. angular displacement		Max. radial displacement ΔK_r [mm]	Max. axial displacement ΔK_a [mm]
	ΔK_w [degree]	ΔK_w [mm]		
SA 75/10	1.6	3.07	0.40	± 1
SB 75/10	0.8	1.54		
SC 75/10	0.56	1.08		
SA 110/16	1.28	3.24	0.32	
SB 110/16	0.64	1.62		
SC 110/16	0.48	1.21		
SB 135/20	0.88	2.61	0.42	
SC 135/20	0.56	1.66		
SD 135/20	0.40	1.19		
SC 165/24	0.48	1.66	0.37	
SD 165/24	0.40	1.38		
SE 165/24	0.32	1.11		

4.7 Disassembly

If you disassemble the magnetic coupling, please absolutely observe the instructions that apply for handling hazardous substances and the accident prevention regulations. In case of doubt, please gather the necessary information before disassembly.



Please observe the warnings and safety instructions.

The disassembly of the magnetic coupling is made in the reverse order of the assembly.

5 Start-up

Before start-up of the coupling, inspect tightening of the setscrews in the hubs, the alignment and adjust, if necessary, and also inspect all screw connections for the tightening torques specified.



If used in potentially explosive atmospheres the setscrews to fasten the hubs as well as all screw connections must be secured against working loose additionally, e. g. conglutinating with Loctite (average strength).

Please observe protection note ISO 16016.	Drawn: 2020-08-24 Pz/Wb	Replacing: KTR-N dated 2019-10-11
	Verified: 2020-09-01 Pz	Replaced by:

**5 Start-up**

Finally the coupling protection against accidental contact must be fitted. It is required in accordance with DIN EN ISO 12100 (Safety of Machinery) and directive 2014/34/EU and must protect against

- access with a little finger
- falling down of solid foreign objects.

The cover may provide for openings intended for necessary heat dissipation. These openings have to comply with DIN EN ISO 13857.

The cover and the containment shroud must be electrically conductive and included in the equipotential bonding. Bellhousings (magnesium share below 7.5 %) made of aluminium and damping rings (NBR) can be used as connecting element between pump and electric motor. The cover may only be taken off with standstill of the unit.

- With start-up and after a longer period of standstill it must be tested (by rotating the driving shaft manually) if coupling and power pack can easily be rotated.
- After a short initial operation the venting process must be repeated several times with standstill of the machine.

Please note:

In general the internal and the external rotor of the magnetic coupling must always run synchronously. The operation in a „torn condition " over a longer period of time must be avoided. After switching off the engine the coupling synchronizes again and is able to transmit the full power.

Before longer periods of standstill liquids tending to solidification, efflorescence, polymerization etc. must be drained from the machine and the containment shroud. If necessary, they must be flushed with a suitable liquid.

A troublefree operation of the MINEX[®]-S can be expected if you observe the maximum ratings of operation and the hints given in these instructions.



For covers with unlocked openings on the top face no light metals must be used if the couplings are used as equipment of equipment group II (*if possible, from stainless steel*).

During operation of the coupling, please pay attention to

- different operating noise
- vibrations occurring.



If you note any irregularities with the coupling during operation, the drive unit must be switched off immediately. The cause of the breakdown must be specified by means of the table „Breakdowns“ and, if possible, be eliminated according to the proposals. The potential breakdowns specified can be hints only. To find out the cause all operating factors and machine components must be considered.

Coating of coupling:

If coated (priming, paintings, etc.) couplings are used in potentially explosive atmospheres, the requirements on conductivity and coating thickness must be considered. With paintings up to 200 µm electrostatic load does not have to be expected. Paintings and coatings exceeding a thickness of 200 µm are generally impermissible for potentially explosive atmospheres. It also applies for multiple coatings exceeding an overall thickness of 200 µm. Make sure with painting or coating that the coupling components are conductively connected with the device/devices to be connected so that the equipotential bonding is not impeded by the paint or coat applied. In addition, make sure that the marking of the coupling remains legible. Painting or coating of the containment shroud is generally not admitted.



6 Breakdowns, causes and elimination

The below-mentioned failures can result in a use of the **MINEX®-S** coupling other than intended. In addition to the specifications given in these operating/assembly instructions make sure to avoid such failures. The errors listed can only be clues to search for the failures. When searching for the failure the adjacent components must generally be considered.



**If used other than intended the coupling can become a source of ignition.
EU directive 2014/34/EU requires special care by the manufacturer and the user.**

General failures with use other than intended:

- Important data for the coupling selection are not forwarded.
- The calculation of the shaft-hub-connection is not considered.
- Coupling components with damage occurred during transport are assembled.
- If the heated hubs are assembled, the permissible temperature is exceeded.
- The clearance of the components to be assembled is not coordinated with one another.
- Tightening torques have been fallen below/exceeded.
- Components are mixed up by mistake/assembled incorrectly.
- No original **KTR** components (purchased parts) are used.
- Maintenance intervals are not observed.

Breakdowns	Causes	Hazard notes for potentially explosive atmospheres	Elimination
Different operating noise and/ or vibrations occurring	Misalignment	Increased temperature on the surface of the containment shroud and the rotors. Increased danger of ignition by hot surfaces.	<ol style="list-style-type: none"> 1) Set the unit out of operation 2) Eliminate the reason for the misalignment (check the centering of the internal and the external rotor in the containment shroud and re-align, if necessary) 3) Check the wear and remove the magnetic chippings completely, if required
	Tearing of magnetic forces	Heating of the coupling due to a lack of heat dissipation, danger of ignition due to hot surfaces	<ol style="list-style-type: none"> 1) Set the unit out of operation 2) Eliminate the reason for tearing (blocking of the pump by particles in the conveyed medium, damage on the bearing, too high starting torque of the engine, „docking“ of the internal or external rotor to the containment shroud subject to bad alignment => see above) 3) Re-synchronize the coupling components at standstill 4) Start the drive again 5) Please check for perfect operation
	Damaged external magnets due to errors in assembly (contact of the external rotor with the containment shroud)		<ol style="list-style-type: none"> 1) Check the external rotor for damages on the magnet 2) Replace the external rotor and assemble it carefully. Please make sure that there is a radial direction to exclude contact with the containment shroud.
Repeated tearing of the magnetic forces	Operating parameters do not meet with the performance of the coupling	Danger of ignition due to hot surfaces	<ol style="list-style-type: none"> 1) Set the unit out of operation 2) Inspect operation parameters 3) If there is tearing during the starting process, reduce the starting torque and/or select a bigger coupling size (considering the installation space), if necessary. 4) Assemble new coupling size, inspect alignment
	Abrasive particles in the conveying medium blocking the pump		<ol style="list-style-type: none"> 1) Inspect the internal rotor and the containment shroud for friction and replace them, if necessary 2) Drain and clean the inside of the containment shroud 3) Use suitable filters recreating the purity of the medium.



When operating with a worn/defective coupling component proper operation is not assured.

Please observe protection note ISO 16016.	Drawn: 2020-08-24 Pz/Wb	Replacing: KTR-N dated 2019-10-11
	Verified: 2020-09-01 Pz	Replaced by:



7 Environment and disposal

7.1 Environment

In the interest of the environment our products comply with directive EC 1907/2006 (REACH). Any substances specified in the REACH SVHC list in an impermissible concentration are not used.

7.2 Disposal

In respect of environmental protection we would ask you to dispose of the packaging or products on termination of their service life in accordance with the legal regulations and standards that apply, respectively.

- **Metal**
Any metal components have to be cleaned and disposed of by scrap metal.
- **Nylon materials**
Nylon materials have to be collected and disposed of by a waste disposal company.

8 Maintenance and service

MINEX®-S is a low-maintenance coupling. We recommend to perform a visual inspection on the coupling at least once a year. Please pay special attention to the condition of the components in the tight air gap between the magnet rotors and the containment shroud.

- Since the flexible machine bearings of the driving and driven side settle during the course of load, inspect the alignment of the coupling and re-align the coupling, if necessary.
- The coupling components have to be inspected for damages.
- The screw connections have to be inspected visually.



Having started up the coupling the tightening torques of the screws have to be inspected during the usual inspection intervals.



With the use in potentially explosive atmospheres observe chapter 10.2 "Inspection intervals for couplings in  potentially explosive atmospheres".

9 Spares inventory, customer service addresses

We recommend to store major spare parts on site to ensure the readiness for use of the machine in case if a coupling fails.

Contact addresses of the KTR partners for spare parts and orders can be obtained from the KTR homepage at www.ktr.com.



KTR does not assume any liability or warranty for the use of spare parts and accessories which are not provided by KTR and for the damages which may incur as a result.

Please observe protection note ISO 16016.	Drawn: 2020-08-24 Pz/Wb	Replacing: KTR-N dated 2019-10-11
	Verified: 2020-09-01 Pz	Replaced by:



10 Enclosure A

Advice and instructions regarding the use in  potentially explosive atmospheres

MINEX®-S coupling with carbon fibre reinforced PEEK containment shrouds are electrically conductive. The components that are conductive or electrically conductive must be included in the equipotential bonding of magnetic couplings.

10.1 Intended use in  potentially explosive atmospheres

Conditions of operation in  potentially explosive atmospheres

MINEX®-S couplings are suitable for the use according to EU directive 2014/34/EU.

Temperature class:

Temperature class	Ambient or operating temperature T _a ¹⁾	Max. surface temperature
T4 (≤ 135 °C)	-40 °C to +110 °C	+130 °C
T5 (≤ 100 °C)	-40 °C to +75 °C	+95 °C
T6 (≤ 85 °C)	-40 °C to +60 °C	+80 °C

Explanation:

The maximum surface temperatures each result from the maximum permissible ambient or operating temperature T_a plus the maximum temperature increase ΔT of 20 K to be considered. For the temperature class a safety margin subject to standard of 5 K is added.

1) The ambient or operating temperature T_a is limited to +130 °C due to the permissible permanent operating temperature (surface temperature).

10.2 Inspection intervals for couplings in  potentially explosive atmospheres

Equipment category	Inspection intervals
all	If the MINEX®-S magnetic coupling is duly operated, maintenance is not required during the complete operating time. An inspection of the coupling, the shaft bearings and the auxiliary seals should be made by suitable specialized staff within the scope of the revision of the unit, but at the latest after 2.5 years.

10.3 Permissible coupling materials in  potentially explosive atmospheres

The materials available for the **MINEX®-S** coupling are basically approved for use in potentially explosive atmospheres, since exclusively components made of steel (external rotor), stainless steel (internal rotor) and carbon fibre reinforced PEEK (containment shroud) are concerned.

Please observe protection note ISO 16016.	Drawn: 2020-08-24 Pz/Wb	Replacing: KTR-N dated 2019-10-11
	Verified: 2020-09-01 Pz	Replaced by:



10 Enclosure A

Advice and instructions regarding the use in  potentially explosive atmospheres

10.4  marking of coupling for potentially explosive atmospheres

The ATEX marking of the MINEX®-S permanent magnetic coupling is made on a coupling component.
For the complete marking refer to the operating/assembly instructions and/or the delivery note/package.

Marking is as follows:

MINEX®-S
<Year>



II 2G Ex h IIC T6 ... T4 Gb
-40 °C ≤ T_a ≤ +60 °C ... +110 °C

KTR Systems GmbH, Carl-Zeiss-Straße 25, D-48432 Rheine

Short marking:

(A short marking is only made if not possible differently for reason of space or functioning.)

MINEX®-S
<Year>



Deviating marking applies until 31st October 2019:



Short marking:



II 2GD c IIC T X

Substance group - gases:

The marking with explosion group IIC includes the explosion groups IIA and IIB.

If the symbol  was punched in addition to marking , the coupling component was supplied by KTR as an unbored or pilot bored version (see chapter 4.2 of the present operating/assembly instructions).

Please observe protection note ISO 16016.	Drawn: 2020-08-24 Pz/Wb	Replacing: KTR-N dated 2019-10-11
	Verified: 2020-09-01 Pz	Replaced by:



10 Enclosure A

Advice and instructions regarding the use in  potentially explosive atmospheres

10.5 Certificate of conformity

Certificate of conformity

corresponding to EU directive 2014/34/EU dated 26 February 2014
and to the legal regulations

The manufacturer - KTR Systems GmbH, D-48432 Rheine - states that the

MINEX®-S Magnetic coupling

in an explosion-proof design described in these assembly instructions are components corresponding to article 2, 3. of directive 2014/34/EU and comply with the general safety and health requirements according to enclosure II of directive 2014/34/EU.

This declaration of conformity is issued under the sole responsibility of the manufacturers KTR Systems GmbH.

The coupling described in here complies with the specifications of the following standards/rules:

- DIN EN ISO 80079-36:2016-12
- DIN EN ISO 80079-37:2016-12
- DIN EN ISO 80079-38:2017-10
- IEC/TS 60079-32-1:2020-01-24

The MINEX®-S is in accordance with the specifications of directive 2014/34/EU.

According to article 13 (3) of directive 2014/34/EU the technical documentation is deposited with the notified body (type examination certificate IBExU04ATEXB023 X):

IBExU
 Institut für Sicherheitstechnik GmbH
 Fuchsmühlenweg 7
 09599 Freiberg

Rheine, 2020-08-24
Date

 i. V.
 Reinhard Wibbeling
 Engineering/R&D

 i. A.
 Marco Vorholt
 Product Manager