

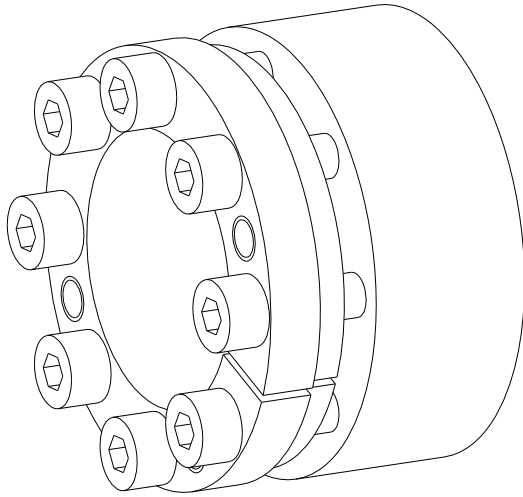

CLAMPEX® KTR 200

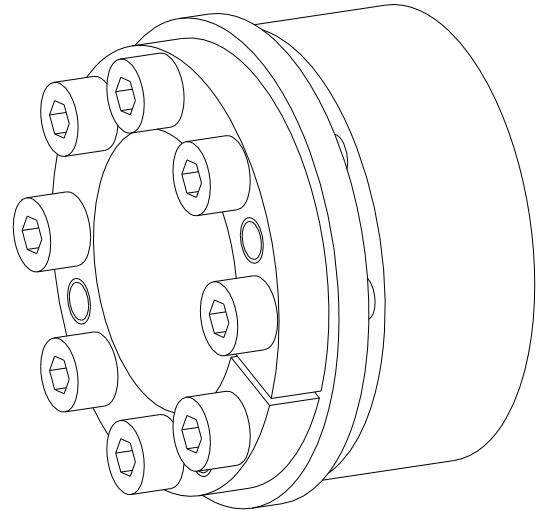

CLAMPEX® KTR 201



The **CLAMPEX® clamping set** is a frictionally engaged, detachable shaft-hub-connection for cylindrical shafts and bores without feather key.

Table of contents

1	Technical data	2
2	Advice	4
2.1	General advice	4
2.2	Safety and advice symbols	4
2.3	General hazard warnings	5
2.4	Intended use	5
3	Storage, transport and packaging	5
3.1	Storage	5
3.2	Transport and packaging	5
4	Assembly	6
4.1	Components of clamping set CLAMPEX® KTR 200 / KTR 201	6
4.2	Assembly of the clamping set	7
4.3	Disassembly of clamping set	8
5	Disposal	8
6	Spares inventory, customer service addresses	9
7	Advice regarding the use in  potentially explosive atmospheres according to EU directive 2014/34/EU	9

1 Technical data

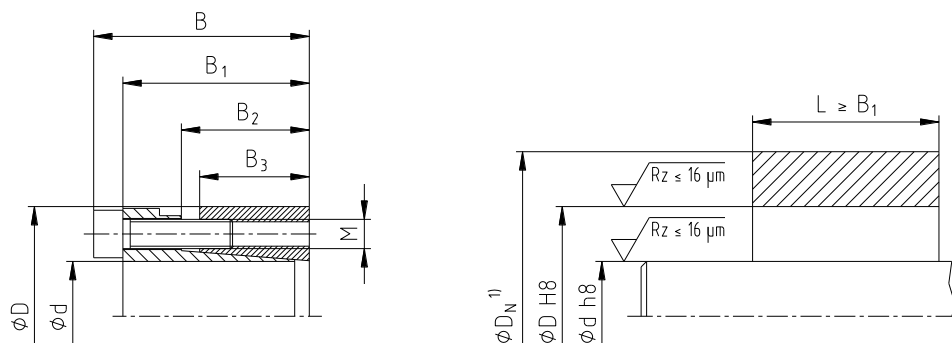

Illustration 1: CLAMPEX® KTR 200

- 1) Dimension D_N : For calculation of hub see catalogue "Drive Technology"
- 2) These are the maximum screw tightening torques. They can be reduced by a maximum of 40 % of the figures specified, with T , F_{ax} , P_W and P_N declining proportionally.

Table 1: CLAMPEX® KTR 200

Dimensions [mm]						Clamping screws DIN EN ISO 4762 - 12.9 $\mu_{total} = 0.14$				Transmittable torque or axial force		Surface pressure between clamping set [N/mm ²]		Weight ~ kg
d x D	B	B ₁	B ₂	B ₃	D ₁	M	Length h	z No.	T _A ²⁾ [Nm]	T [Nm]	F _{ax} [kN]	Shaft P _W	Hub P _N	
20 x 47	48	42	31	26	53	M6	25	6	17	530	53	270	115	0.4
22 x 47	48	42	31	26	53	M6	25	6	17	580	53	245	114	0.4
24 x 50	48	42	31	26	56	M6	25	6	17	630	53	223	107	0.4
25 x 50	48	42	31	26	56	M6	25	6	17	660	53	215	108	0.4
28 x 55	48	42	31	26	61	M6	25	6	17	740	53	193	98	0.5
30 x 55	48	42	31	26	61	M6	25	6	17	790	53	179	98	0.5
32 x 60	48	42	31	26	66	M6	25	8	17	1150	72	229	122	0.6
35 x 60	48	42	31	26	66	M6	25	8	17	1300	74	217	126	0.5
38 x 65	48	42	31	26	71	M6	25	8	17	1300	68	184	107	0.6
40 x 65	48	42	31	26	71	M6	25	8	17	1400	70	179	110	0.6
42 x 75	59	51	35	30	81	M8	30	6	41	2000	95	200	112	1.0
45 x 75	59	51	35	30	81	M8	30	6	41	2200	98	192	115	1.0
48 x 80	59	51	35	30	86	M8	30	8	41	3200	133	246	147	1.1
50 x 80	59	51	35	30	86	M8	30	8	41	3300	132	233	146	1.1
55 x 85	59	51	35	30	91	M8	30	8	41	3600	131	210	136	1.2
60 x 90	59	51	35	30	96	M8	30	8	41	3900	130	192	128	1.2
65 x 95	59	51	35	30	101	M8	30	8	41	4300	132	180	123	1.3
70 x 110	71	61	46	40	119	M10	30	8	83	7500	214	203	129	2.2
75 x 115	71	61	46	40	124	M10	30	8	83	8000	213	189	123	2.3
80 x 120	71	61	46	40	129	M10	30	8	83	8500	213	176	117	2.4
85 x 125	71	61	46	40	134	M10	30	10	83	11400	268	209	142	2.6
90 x 130	71	61	46	40	139	M10	30	10	83	12000	267	196	136	2.7
95 x 135	71	61	46	40	144	M10	30	10	83	12600	265	185	130	2.8
100 x 145	80	68	52	45	155	M12	35	8	145	15000	300	177	122	3.9
110 x 155	80	68	52	45	165	M12	35	8	145	16500	300	161	114	4.2
120 x 165	80	68	52	45	175	M12	35	10	145	22500	375	184	134	4.5
130 x 180	80	68	52	45	188	M12	35	12	145	29000	446	202	146	5.5
140 x 190	90	76	58	50	199	M14	40	10	210	32000	457	173	128	6.6
150 x 200	90	76	58	50	209	M14	40	12	210	41000	547	193	145	6.9
160 x 210	90	76	58	50	219	M14	40	12	210	44000	550	182	139	7.4
170 x 225	90	76	58	50	234	M14	40	14	210	54500	641	200	151	8.6
180 x 235	90	76	58	50	244	M14	40	14	210	57500	639	188	144	9.1
190 x 250	90	76	58	50	259	M14	40	15	210	65000	684	191	145	10.6
200 x 260	90	76	58	50	269	M14	40	15	210	68000	680	180	139	11.2

1 Technical data

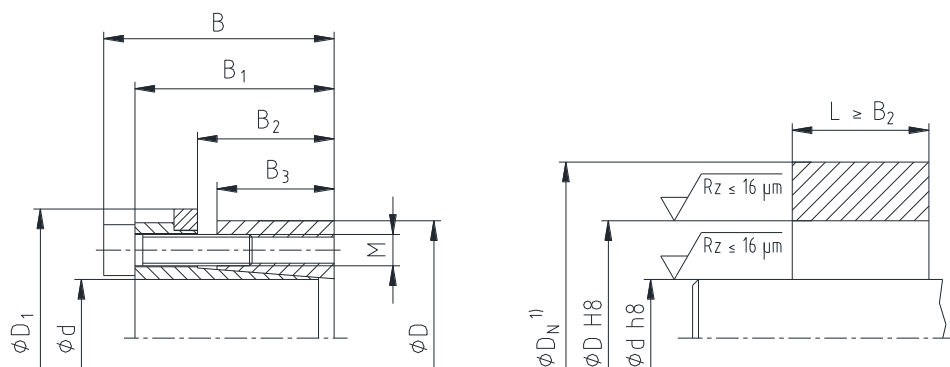

Illustration 2: CLAMPEX® KTR 201

- 1) Dimension D_N : For calculation of hub see catalogue "Drive Technology"
- 2) These are the maximum screw tightening torques. They can be reduced by a maximum of 40 % of the figures specified, with T , F_{ax} , P_W and P_N declining proportionally.

Table 2: CLAMPEX® KTR 201

Dimensions [mm]						Clamping screws DIN EN ISO 4762 - 12.9 $\mu_{total} = 0.14$				Transmittable torque or axial force		Surface pressure between clamping set [N/mm ²]		Weight ~ kg
d x D	B	B ₁	B ₂	B ₃	D ₁	M	Lengt h	z No.	T _A ²⁾ [Nm]	T [Nm]	F _{ax} [kN]	Shaft P _W	Hub P _N	
20 x 47	48	42	31	26	53	M6	25	6	17	320	32	163	69	0.4
22 x 47	48	42	31	26	53	M6	25	6	17	360	33	152	71	0.4
24 x 50	48	42	31	26	56	M6	25	6	17	390	33	138	66	0.4
25 x 50	48	42	31	26	56	M6	25	6	17	400	32	131	65	0.4
28 x 55	48	42	31	26	61	M6	25	6	17	450	32	117	60	0.5
30 x 55	48	42	31	26	61	M6	25	6	17	490	33	111	61	0.5
32 x 60	48	42	31	26	66	M6	25	8	17	690	43	137	73	0.6
35 x 60	48	42	31	26	66	M6	25	8	17	750	43	125	73	0.5
38 x 65	48	42	31	26	71	M6	25	8	17	820	43	116	68	0.6
40 x 65	48	42	31	26	71	M6	25	8	17	860	43	110	67	0.6
42 x 75	59	51	35	30	81	M8	30	6	41	1300	62	130	73	1.0
45 x 75	59	51	35	30	81	M8	30	6	41	1400	62	122	73	1.0
48 x 80	59	51	35	30	86	M8	30	8	41	1900	79	146	87	1.1
50 x 80	59	51	35	30	86	M8	30	8	41	2000	80	141	88	1.1
55 x 85	59	51	35	30	91	M8	30	8	41	2200	80	129	83	1.2
60 x 90	59	51	35	30	96	M8	30	8	41	2400	80	118	79	1.2
65 x 95	59	51	35	30	101	M8	30	8	41	2600	80	109	74	1.3
70 x 110	71	61	46	40	119	M10	30	8	83	4600	131	125	79	2.3
75 x 115	71	61	46	40	124	M10	30	8	83	5000	133	118	77	2.4
80 x 120	71	61	46	40	129	M10	30	8	83	5200	130	108	72	2.6
85 x 125	71	61	46	40	134	M10	30	10	83	7000	165	128	87	2.7
90 x 130	71	61	46	40	139	M10	30	10	83	7400	164	121	84	2.8
95 x 135	71	61	46	40	144	M10	30	10	83	7800	164	115	81	2.9
100 x 145	80	68	52	45	155	M12	35	8	145	9800	196	116	80	4.1
110 x 155	80	68	52	45	165	M12	35	8	145	10700	195	104	74	4.4
120 x 165	80	68	52	45	175	M12	35	10	145	14600	243	120	87	4.7
130 x 180	80	68	52	45	188	M12	35	12	145	19000	292	133	96	5.7
140 x 190	90	76	58	50	199	M14	40	10	230	23000	329	125	92	6.9
150 x 200	90	76	58	50	209	M14	40	12	230	30000	400	141	106	7.2
160 x 210	90	76	58	50	219	M14	40	12	230	32000	400	133	101	7.8
170 x 225	90	76	58	50	234	M14	40	14	230	39000	459	143	118	9.0
180 x 235	90	76	58	50	244	M14	40	14	230	41000	456	134	103	9.5
190 x 250	90	76	58	50	259	M14	40	15	230	46400	488	136	104	11.1
200 x 260	90	76	58	50	269	M14	40	15	230	48800	488	129	100	11.7



1 Technical data

Tolerances, surfaces

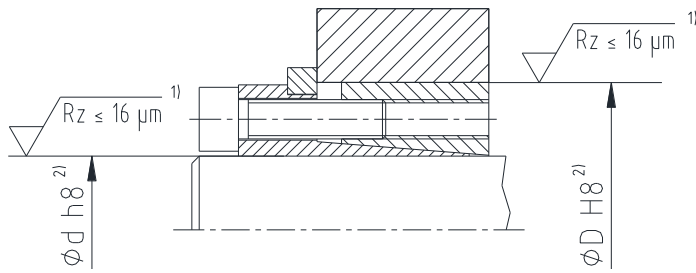

Illustration 3: Tolerances and surfaces (example: CLAMPEX® KTR 201)

- 1) One proper turning process is sufficient ($Rz \le 16 \mu m$).
- 2) Highest permissible tolerance of hub or shaft.

2 Advice

2.1 General advice

Please read through these operating/assembly instructions carefully before you mount the clamping set. Please pay special attention to the safety instructions!
The operating/assembly instructions are part of your product. Please store them carefully and close to the clamping set. The copyright for these operating/assembly instructions remains with KTR.

2.2 Safety and advice symbols

- Warning of potentially explosive atmospheres**

This symbol indicates notes which may contribute to preventing bodily injuries or serious bodily injuries that may result in death caused by explosion.
- Warning of personal injury**

This symbol indicates notes which may contribute to preventing bodily injuries or serious bodily injuries that may result in death.
- Warning of product damages**

This symbol indicates notes which may contribute to preventing material or machine damage.
- General advice**

This symbol indicates notes which may contribute to preventing adverse results or conditions.

Please observe protection note ISO 16016.	Drawn: 2022-05-25 Ka/Jh	Replacing: KTR-N dated 2021-03-16
	Verified: 2022-05-31 Pz	Replaced by:



2 Advice

2.3 General hazard warnings



With assembly and disassembly of the clamping set it has to be made sure that the entire drive train is secured against accidental switch-on. You may be seriously hurt by rotating parts. Please make absolutely sure to read through and observe the following safety indications.

- All operations on and with the clamping set have to be performed taking into account "safety first".
- Please make sure to switch off the power pack before you perform your work on the clamping set.
- Secure the power pack against accidental switch-on, e. g. by providing warning signs at the place of switch-on or removing the fuse for current supply.
- Do not reach into the operation area of the machine as long as it is in operation.
- Please secure the rotating drive components against accidental contact. Please provide for the necessary protection devices and covers.

2.4 Intended use

You may only assemble and disassemble the clamping set if you

- have carefully read through the operating/assembly instructions and understood them
- are technically qualified and specifically trained (e. g. safety, environment, logistics)
- are authorized by your company

The clamping set may only be used in accordance with the technical data (see chapter 1). Unauthorized modifications on the clamping set are not admissible. We will not assume liability for any damage that may arise. In the interest of further development we reserve the right for technical modifications.

The clamping set described in here corresponds to the technical status at the time of printing of these operating/assembly instructions.

3 Storage, transport and packaging

3.1 Storage

The clamping sets are supplied in preserved condition and can be stored at a dry and roofed place for 6 - 9 months.



**Humid storage rooms are not suitable.
Please make sure that condensation is not generated.**

3.2 Transport and packaging



In order to avoid any injuries and any kind of damage please always make use of proper transport and lifting equipment.

The clamping sets are packed differently each depending on size, quantity and kind of transport. Unless otherwise contractually agreed, packaging will follow the in-house packaging specifications of KTR.

Please observe protection note ISO 16016.	Drawn: 2022-05-25 Ka/Jh	Replacing: KTR-N dated 2021-03-16
	Verified: 2022-05-31 Pz	Replaced by:



4 Assembly

Generally the clamping set is supplied in mounted condition. Before assembly the clamping set has to be inspected for completeness.

4.1 Components of clamping set CLAMPEX® KTR 200 / KTR 201

Component	Quantity	Description
1	1	Outer ring (slit)
2	1	Inner ring (slit)
3	1	Axial ring (only with KTR 201)
4	see table 1 and 2	Cap screw DIN EN ISO 4762

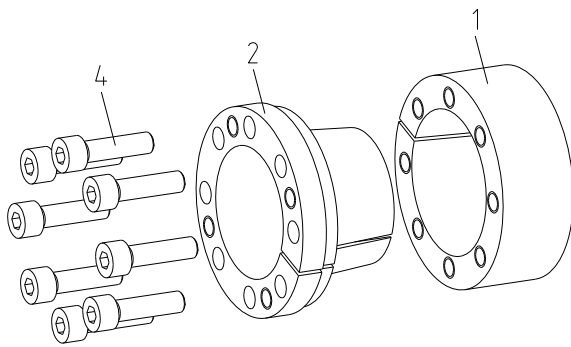

Illustration 4: CLAMPEX® KTR 200

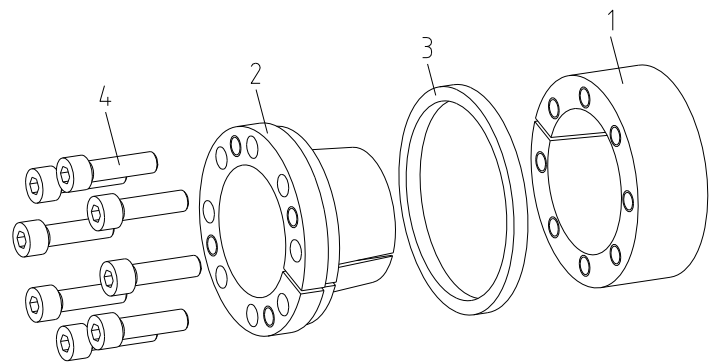

Illustration 5: CLAMPEX® KTR 201



With assembly none of the extraction threads of the internal ring (component 2) must be congruent with the slot of the external ring (component 1).



Dirty or used clamping sets have to be disassembled and cleaned before assembly. Afterwards apply thin oil lightly (e. g. Ballistol Universal oil or Klüber Quietsch-Ex).

**4 Assembly****4.2 Assembly of the clamping set**

- Inspect the fit of shaft and hub for the tolerance specified (see illustration 3).
- Clean the surfaces of the clamping set marked in illustration 6 as well as of shaft and hub and afterwards apply thin oil lightly (e. g. Ballistol Universal oil or Klüber Quietsch-Ex).

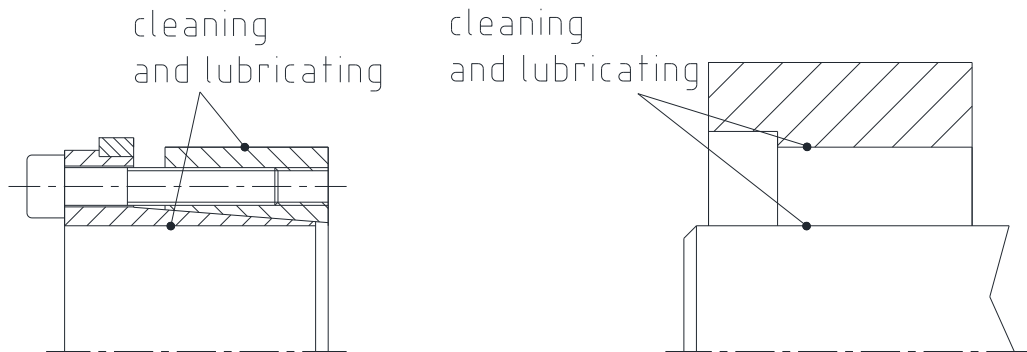

Illustration 6: Cleaning and lubricating the contact surfaces (example: CLAMPEX® KTR 201)



Oils and greases with molybdenum disulphide or other high-pressure additives, additives of Teflon and silicone as well as internal lubricants reducing the coefficient of friction significantly must not be used. When mounting the tapers of the clamping set free from oil the tabular and calculated parameters deviate.

- Unscrew the clamping screws by several revolutions so that the external ring detaches slightly from the internal ring.
- To facilitate the assembly fasten the internal and external ring by two clamping screws via the extraction threads (see illustration 7). Afterwards insert the clamping set KTR 200 / KTR 201 between shaft and hub.

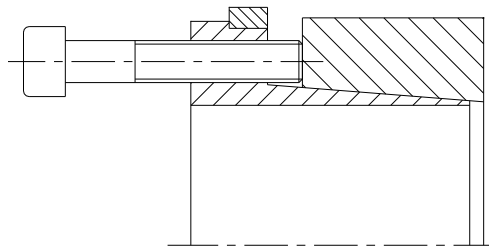

Illustration 7: Fastening the clamping set (example: CLAMPEX® KTR 201)

- Remove the clamping screws used for fastening and screw them into the thread of the external ring.
- Hand-tighten the clamping screws first and align the internal clamping ring with the hub.
- Please make sure with KTR 201 that the axial back-up ring (component 3) for axial fastening fits the hub evenly.
- Tighten the clamping screws evenly crosswise gradually to the tightening torque specified in table 1 or 2. Repeat this process until all clamping screws have reached the tightening torque.



During assembly the hub is displaced axially to the shaft with KTR 200.



4 Assembly

4.3 Disassembly of clamping set



**Driving components released or falling down may cause injury to persons or damage on the machine.
Secure the driving components before disassembly.**

- Untighten and unscrew all clamping screws evenly one after another.
- Screw the clamping screws into the extraction threads of the internal ring (component 2) (see illustration 8 and 9).
- Tighten the clamping screws evenly crosswise by 1/4 revolution. Increase the extraction torque gradually until the external ring (component 1) and internal ring (component 2) are separated.
- Take out the clamping set released between shaft and hub.

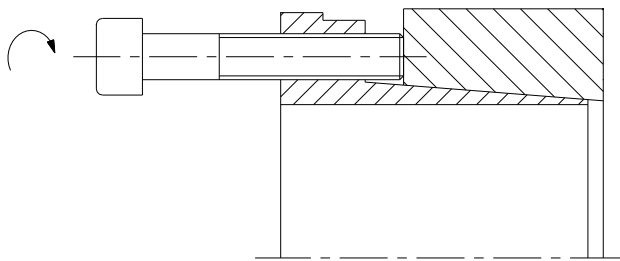

Illustration 8: Releasing the clamping set KTR 200

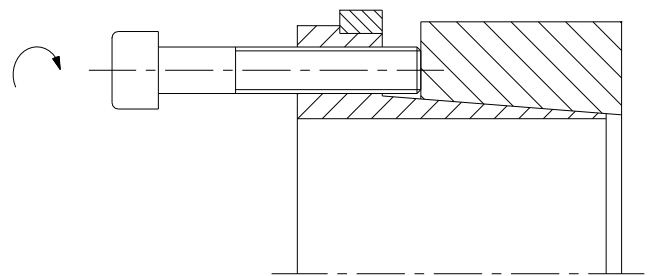

Illustration 9: Releasing the clamping set KTR 201



If these hints are not observed or operating conditions are not taken into account with the selection of the clamping set, the operation of the clamping set may be affected.



Used clamping sets have to be disassembled and cleaned before assembly. Afterwards apply thin oil lightly (e. g. Ballistol Universal oil or Klüber Quietsch-Ex).

5 Disposal

In respect of environmental protection we would ask you to dispose of the packaging or products on termination of their service life in accordance with the legal regulations and standards that apply, respectively.
All clamping sets consist of metal. Any metal components have to be cleaned and disposed of by scrap metal.

Please observe protection note ISO 16016.	Drawn: 2022-05-25 Ka/Jh	Replacing: KTR-N dated 2021-03-16
	Verified: 2022-05-31 Pz	Replaced by:

6 Spares inventory, customer service addresses

A basic requirement to ensure the readiness for use of the drive components is a stock of some clamping sets on site.

Contact addresses of the KTR partners for spare parts and orders can be obtained from the KTR homepage at www.ktr.com.



KTR does not assume any liability or warranty for the use of spare parts and accessories which are not provided by KTR and for the damages which may incur as a result.

7 Advice regarding the use in  potentially explosive atmospheres according to EU directive 2014/34/EU

If used in potentially explosive atmospheres the type and size of clamping set (for category 3 only) has to be selected in that the difference between the peak torque of the machine including all operating parameters and the rated torque of the clamping hub at least corresponds to a safety factor of $s = 2.0$.

CLAMPEX® clamping sets are not part of directive 2014/34/EU, since

- this product is a torsionally rigid, backlash-free, frictionally engaged connection with one or more taper clamping ring(s) ensured by several screws.
(Clamping screws have to be secured, e. g. by means of a medium strength adhesive.)
- due to the design of clamping sets a fracture/failure is not likely (frictional heat is only generated by improper assembly/tightening torques, i. e. with use other than for intended purpose).