

Reliable performance in sophisticated areas.

Hydraulic components



Made for Motion





KTR Systems – Solutions across industries for a global market.

As a progressive and innovative knowledge partner for our customers, we actively shape the technological future. By consciously responding to the needs of our customers and having a deep understanding of their technology, it is possible for us to develop cross-industry solutions. In doing so, we always strive for excellence and optimise existing approaches. And this has been the case since 1959.

PART OF EXCELLENCE

Our philosophy of PART OF EXCELLENCE is reflected in every single component and service we provide. With our expertise and innovation, we achieve top performance together with our customers. KTR is at home in industrial markets on all continents with more than 500 employees at its headquarters in Rheine, more than 1,200 employees worldwide, 24 subsidiaries and over 90 sales partners. As a **leading manufacturer of high-quality drive technology, braking and cooling systems and hydraulic components** KTR is a reliable partner for all companies that want to keep moving. As a leading expert in these fields, we take pride in offering our versatile solutions in the following industry:

→ Hydraulics

Drive technology and shaft connections

Brake systems

Cooling systems

Hydraulic components



KTR worldwide – Our locations for quality and service.

○ Headquarters (Rheine / Germany)

● 24 subsidiaries

90 sales partners

More than 1,200 employees worldwide



Our components for hydraulics

Hydraulics is facing a growing competition with other technologies, specifically electromechanical drive technology. For that reason the trend is clearly towards servo hydraulics, the high power density of which is combined with high accuracy, good controllability and high efficiency.

Another current subject is the users' request for low-noise hydraulic systems. Apart from that hydraulic systems are increasingly integrated in superordinate systems in terms of control and data processing technology for the purpose of Industry 4.0 (energy and thermo management, condition monitoring...).

For almost 50 years our business unit of hydraulics has provided a continuously growing portfolio of high-quality hydraulic components originating from in-house development and production. It includes sophisticated system modules for thermo management such as coolers and tank heaters. This means that we are a "full liner" providing the hydraulics industry with bellhousings, foot flanges, damping elements, coolers and oil tanks working in a close cooperation with our customers. It starts with projecting: here we are working with 3D models which are integrated in the customers' data records. The complete power packs can be assessed and optimized via virtual reality, if necessary.



On our website www.ktr.com/en



Industries you can find more information.

BELLOUSINGS

DAMPING ELEMENTS

FOOT FLANGES

Page 06

1

Bellhousings made of aluminium
Circular and rectangular type

Page 06

2

Bellhousing PG
made of cast iron

Page 06

3

Bellhousings PSG
for servo hydraulics

Page 07

4

Bellhousings PS
made of steel for IEC and servo motors

Page 07

5

Damping rings DT/DTV/DTSV
for structure-borne noise separation

Page 07

6

Damping ring type D
for noise reduction

Page 07

7

Damping rod
for structure-borne noise separation

Page 08

8

Foot flanges type PTFL
in light type

Page 08

9

Foot flanges type PTFS
made of aluminium or nodular iron

COOLING SYSTEMS

TANKS

Page 09

10

OAC
Oil-air cooler

Page 09

11

OPC
Oil-air OPC cooler with integrated pump

Page 09

12

OPC2
Oil-air cooler with separately switchable cooler motor

Page 09

13

PIK
Bellhousing with integrated oil/air cooler

Page 10

14

PHE
Oil-water cooler with plate heat exchanger

Page 10

15

TAK/TP
Oil-water cooler with bundle of pipes heat exchanger

Page 11

16

BAK
Aluminium tanks

Page 11

17

BSK
Steel tanks

TEMPERATURE CONTROL AND MONITORING

Page 11

18

NVT
Level temperature switch

Page 11

19

NVT-E
Electronic level temperature switch

Page 12

20

TEHM
Tank heater with magnetic clamp

Page 12

21

EH Tank heater
Immersion heater

Page 12

22

EHP Tank heater
Inserted heating cartridges with temperature control

KTR SYSTEMS

You can also find more components in our comprehensive four product catalogues in the download area:

↓

www.ktr.com

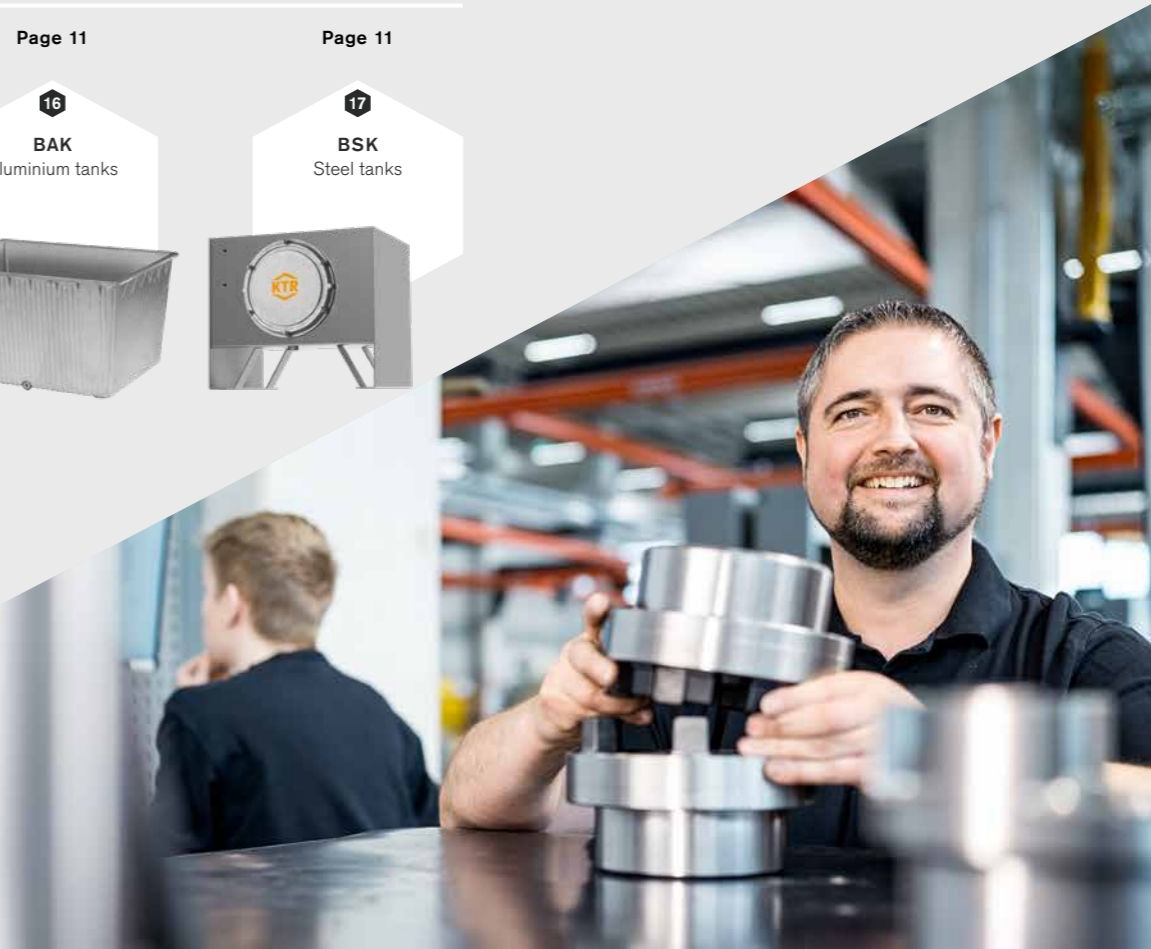

◊ We provide the industry with a continuously growing range of **hydraulic components** from our in-house development. The advantages: Accurate selection, high-quality processing, short-term availability and low prices. We make our contribution with passion and creativity, true to our motto **PART OF EXCELLENCE**.



Bellhousings PS
made of steel for IEC
and servo motors

4

Our **bellhousings made of steel** are suitable for extreme requirements. Up to size 300 they are turned from the bar stock, from size 350 they are welded. Our bellhousings made of steel can be manufactured in almost every length and version.

Bellhousings for IEC and servo motors
Special lengths and special versions available
33.1 Certificates
Available in stainless steel

BELLHOUSINGS

Aluminium-bellhousings is a circular and rectangular type on the pump side. The material aluminium enweight while maintaining high strength. If used inside buildings, protective coat is not necessary.

Motor side for electric motors according to IEC
Available in different versions
Bellhousings according to VDMA standard 24561
Low weight



Size
160 – 800

Bellhousings Aluminium

1

DAMPING ELEMENTS

For structure-borne noise separation of the motor- / pump-unit with vertical mounting. The **damping rings DT/DTV** are a reasonable measure or structure-borne noise separation with vertical mounting generating a similar effect as damping rods. The DT/DTV rings stabilise the adjacent components like, as an example, the tank cover, too.

DT for horizontal and vertical design
DTV for vertical assembly only
Vulcanized sealing lips for sealing to tank and bellhousing
DTSV for servo-hydraulic applications, V1
DT is protected against tearing off by technical design



Size
160 – 800

Damping rings DT / DTV / DTSV
for structure-borne noise separation

5



Bellhousing PG
Cast iron

2

Size
200 – 1.000

Bellhousings PG made of cast or nodular iron for applications with special requirements, such as high weight loads and operational shocks, but also for maritime use (salt water) and underground. Type PG was developed for heavy pump combinations such as mobile, offshore and underground applications.

Cast iron – higher strength compared to aluminium
Good noise damping properties
Horizontal mounting in combination with KTR foot flanges possible
Bellhousing with venting hole and leakage oil bore available on request



Damping rod D
for noise reduction

6

Size
Ø 150 – Ø 350 mm

With increasing power density and lighter components, the noise level increases. KTR offers effective secondary damping measures in this regard, in particular the **Damping Ring D** between the pump and the bellhousing. Due to its locking mechanism it has twice the effective surface, accepts more weight and noticeably reduces noise.

D150 to D330 with particularly strong locking mechanism
Serves for structure-borne noise paration between pump and drive unit
Noise reduction by reflection of structure-borne noise vibrations

Bellhousings made of cast or nodular iron for servo-hydraulic drives, particularly in servo hydraulics. Suitable for heavy loads, shocks and use in maritime and underground applications. The **PSG bellhousing** with rectangular flange is specially designed for servo motors.

Flange dimensions suitable for rectangular connection diagrammes of servo motors (type PSG)
Good noise damping properties
Horizontal mounting in combination with KTR foot flanges possible
Bellhousing with venting hole and oil bleed available on request



Size
200 – 350

Bellhousings PSG
for servo hydraulics

3

Our **damping rods** are an effective structure-borne noise separation of the motor-pump-unit with horizontal mounting on the tank. The structure-borne noise is effectively damped by the combination of metal and natural rubber. Moreover, the damping rods reinforce the adjacent structure such as seams or welded reinforcement sheets which has a positive effect on structure-borne noise separation.

No metallic connection between structure and substructure
Reinforce the substructure they are mounted on
Fully machined from stock for motors B3/5 (DSM) or for use with foot flange (DSFL, DSFS) and PIK (DSK)
Reduce the structure-borne noise and lower the sound level
Also available for NEMA motors



Damping rod
for structure-borne noise separation

7

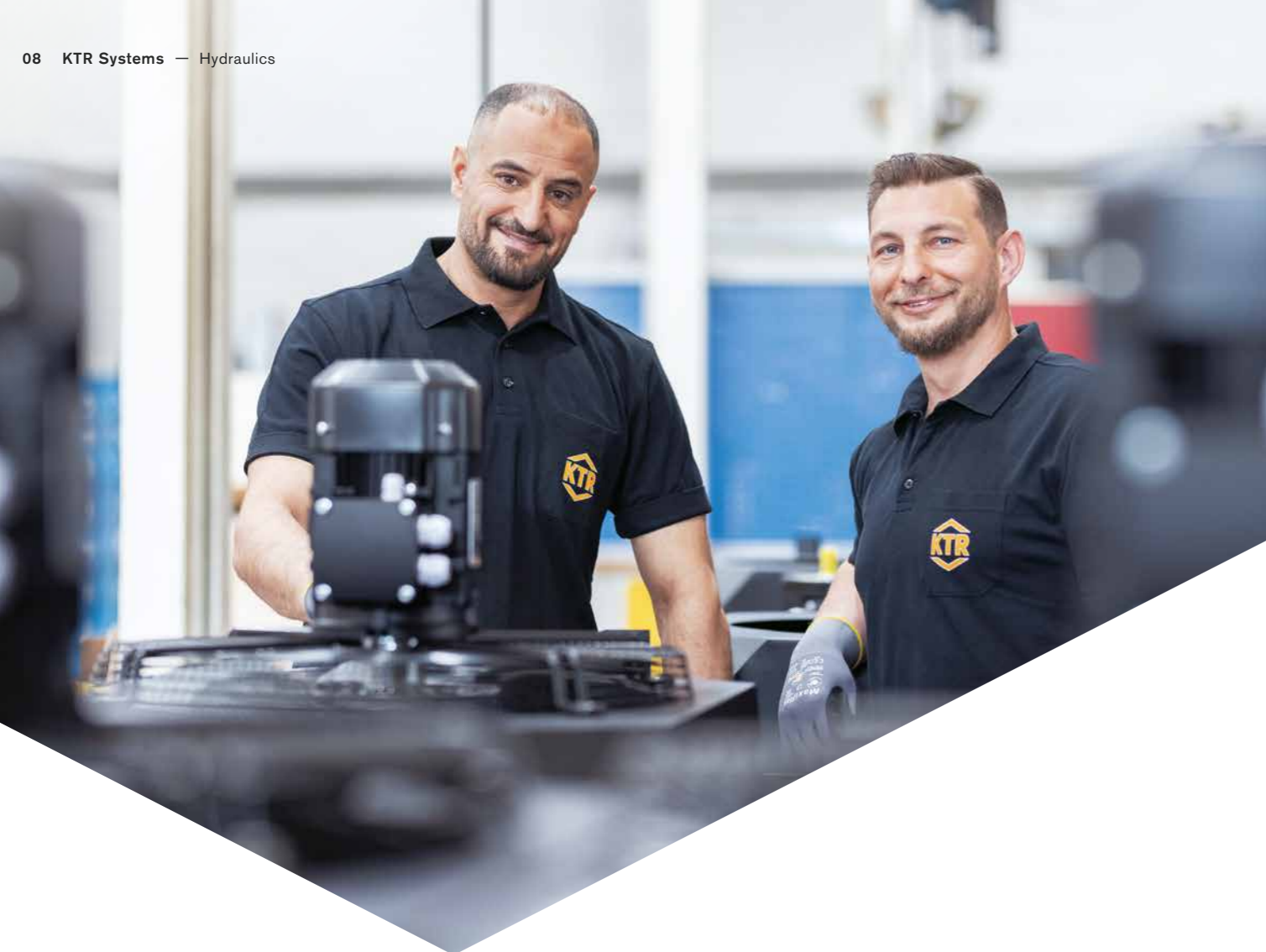

COOLING SYSTEMS

High-performance cooling for stationary hydraulics and mobile machines. Compact and high-performance oil cooler type **OAC**. Standard fan drive for 12V / 24V, 230 V / 400 V or hydraulic operation.

- Available in "maritime" and "ATEX" versions
- Easy to service and good options of cleaning
- Low sound pressure level

10

2 – 350 kW
cooling capacity

OAC
Oil-air coolers



11

2 – 110 kW
cooling capacity

OPC
Oil-air coolers



The powerful bypass flow cooling unit type **OPC** is particularly suitable for gear oil cooling. In addition there are hydraulic and lubricating oils as well as water glycol. The flexible design of the series allows to use different pumps or motors with different voltage ranges, as needed.

- Electric motor specified acc. to protection class IP55
- Marine type available
- Type certified acc. to ATEX available
- Optionally available with filter

FOOT FLANGES

The PTFL foot flange is a compact and space-saving arrangement where the motor may protrude over the tank edge. Additional mounting space is created in this way. Despite their compact design, the PTFL foot flanges are very resilient and suitable for all stationary hydraulic drives.

- Compact, space-saving design
- Materials: aluminium
- Reduces warehousing to one motor only for horizontal and vertical mounting

8

Size
160 – 350

Foot flanges type PTFL in light type



The **OPC2** cooling unit offers flexible combinations of components thanks to its construction kit system. Motor and pump can be operated independently – this means that, provided there is sufficient ambient cooling, only the pump remains active and continues to ensure lubrication. Standard motors ensure fast availability.

- Electric motor specified acc. to protection class IP55
- Marine version available
- Type certified acc. to ATEX available
- Drive motor 230 / 400V 50 Hz and 460V 60 Hz, special voltages on request

12

2 – 110 kW
cooling capacity

OPC2
Oil volume flow with a separately switchable cooler motor

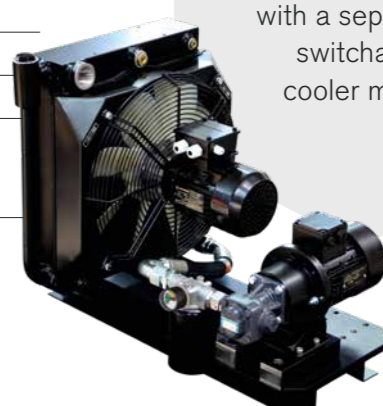

9

Size
200 – 660

Foot flanges PTFS made of aluminium or nodular iron



Horizontal mounting is possible in combination with KTR foot flanges type **PTFS** with all bellhousings. Type PTFS (heavy type compared to PTFL) is available in nodular iron in almost every size.

- Heavy types for higher loads
- Compact, space-saving design
- Materials: aluminium and nodular iron

13

1 – 5,5 kW
cooling capacity

PIK
Bellhousing with integrated oil-air cooler



PIK is a bellhousing with integrated cooler. The compact and low-priced series was designed for cooling leakage oil of hydraulic pumps and lower oil volume flow. The size is defined by the electric motor. Afterwards it can be verified whether the cooling capacity to be reached is sufficient for the drive.

- Compact design
- For IEC motor sizes from 80 – 180 l
- Cooling capacity up to 5,5 kW
- Flow rates up to 80 l/min
- Mountable damping rods
- Also for vertical installation

The **PHE** oil-water cooler is a soldered plate heat exchanger made up of two end plates, specifically corrugated flow plates and four connections. The stamped plates of the plate heat exchanger are made of stainless steel and soldered with copper, they generate high power density in tight spaces.

Operating temperature: -10 °C to +200 °C
 Maximum permissible operating pressure:
 PHE 100: 10 bars / PHE 200 - 500: 30 bars
 Cooling capacity up to 200 kW attainable
 Oil flow: 5 – 450 l/min
 Water flow: 5 bis 250 l/min

1 – 150 kW cooling capacity



PHE
Oil-water cooler with plate heat exchanger

14



BAK
Aluminium tanks

16

TANKS

The **BAK** aluminium tanks are shape bound tanks manufactured by low-pressure diecasting or pressure diecasting, depending on the type. BAK tanks have a good cooling capacity due to high thermal conductivity and large surfaces. The material aluminium makes them lightweight so that they can be delivered in small quantities via parcel service.

Made of aluminium, no extra painting required
 Available with and without oil collecting groove
 Good heat dissipation rate by high thermal conductivity
 For pressureless operation (max. 0.5 bars)
 All tanks 100% leak-proof and stackable

TAK/TP
Oil-water cooler with bundle of pipes heat exchanger

15

3 – 500 kW cooling capacity



The **TAK / TP** cooler ranges were originally designed for hydraulic systems, but are equally suitable for cooling lubricating oils and heat recovery. The tube bundle, which is expandable on both sides, reduces thermal stresses and ensures high reliability. A Seawater version is available.

Easy to clean
 Tube bundle can be replaced
 Oil flow: 0 – 1,300 l/min
 Water flow: 5 – 800 l/min

The **BSK** series offers a cost-effective alternative to DIN containers. Made of quality steel, seal seams are welded twice and inspected for 100% tightness. Blasting SA 2,5 and 2K epoxy resin primer with high resistance to oil
 Optional: Final painting, additional connections and stainless steel design. Easy access due to tank covers.

Tank according to KTR company standard
 With bores for optional filler neck and oil level indicator
 With pre-assembled cleaning cover
 Cover machining according to customer specification possible

40 – 400 litres

BSK
Steel tanks



17

NVT
Level temperature-switch

18



The **NVT** (level temperature switch) serves for monitoring the level and the temperature of simple hydraulic plants. This series comprises simple electrical operating equipment without its own voltage source. In addition this level temperature switch has a powerful float in spite of its small dimensions.

Suitable for mineral oils
 Other lengths on request
 Plug acc. to DIN 43650 (standard)

The **NVT-E** reliably monitors the fill level and temperature in hydraulic and lubricating oil tanks. Filling level and temperature in hydraulic and lubricating oil tanks. Designed for compact tanks, it combines minimal dimensions with high operational density. Programmable switch outputs and a direct status display enable flexible implementation options.

Clearly visible LED display with status indicator – swivelling by 270°
 Type "4": 4 programmable switch outputs to be randomly assigned as level and temperature signal
 Type "2NT": 2 switch terminals to be freely programmed and 2 analogue outputs (level and temp.)

-20 °C up to +80 °C ambient temperature

NVT-E
Electronic level temperature switch

19



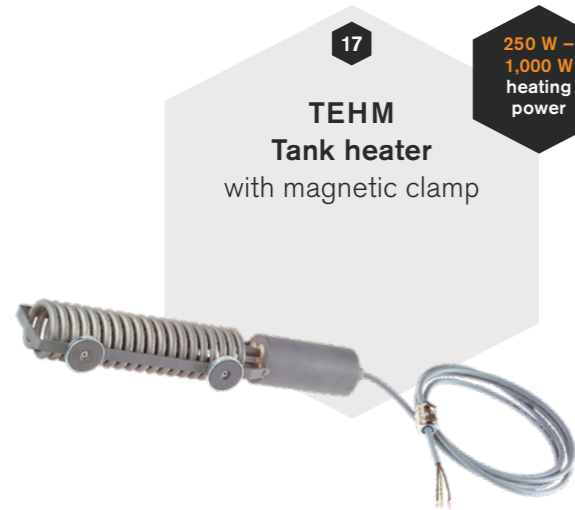

17

TEHM
Tank heater
with magnetic clamp

250 W –
1,000 W
heating
power

Tank heater with magnetic clamps (**TEHM**) are used for heating of oils, for example in hydraulic tanks or gearboxes. They prevent frost damage at low temperatures and keep liquids within the optimum temperature range. Due to their easy mounting process they are ideally suited for retrofitting of plants that have already commenced operation.

- _____ Ideally suitable for retrofitting
- _____ For mounting in the oil tank
- _____ Horizontal mounting on the tank ground or vertical mounting on the tank wall
- _____ Fastening via magnetic clamps

380 W –
2,300 W
heating
power

18

EH
Tank heater
Immersion heater

Inserted heaters (immersion heaters) serve for heating oils in hydraulic tanks or gearboxes. They are made up of U-shaped, curved tubular heaters with welded in threaded nipple and galvanised connection cover. Temperature control can be installed inside and outside.

- _____ Heating power from 380 W to 2,300 W
- _____ Immersion heater

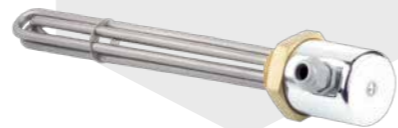

17

EHP
Tank heater
Inserted heating
cartridges with
temperature control

400 W –
4,900 W
heating
power

Cartridge heaters heating lubricating and hydraulic oil in oil tanks and gearboxes. Temperature control can be installed inside and outside. The heating elements can be replaced without draining the medium as the protective pipe of the heating insert remains permanently in the tank. Ideal for containers larger than 200 litres, mounted using threaded nipples and seals.

- _____ Inserted heating cartridges with temperature control for heating cold and viscous oil
- _____ Replacement of ceramic cartridges possible without oil drain
- _____ Horizontal mounting of heating cartridges

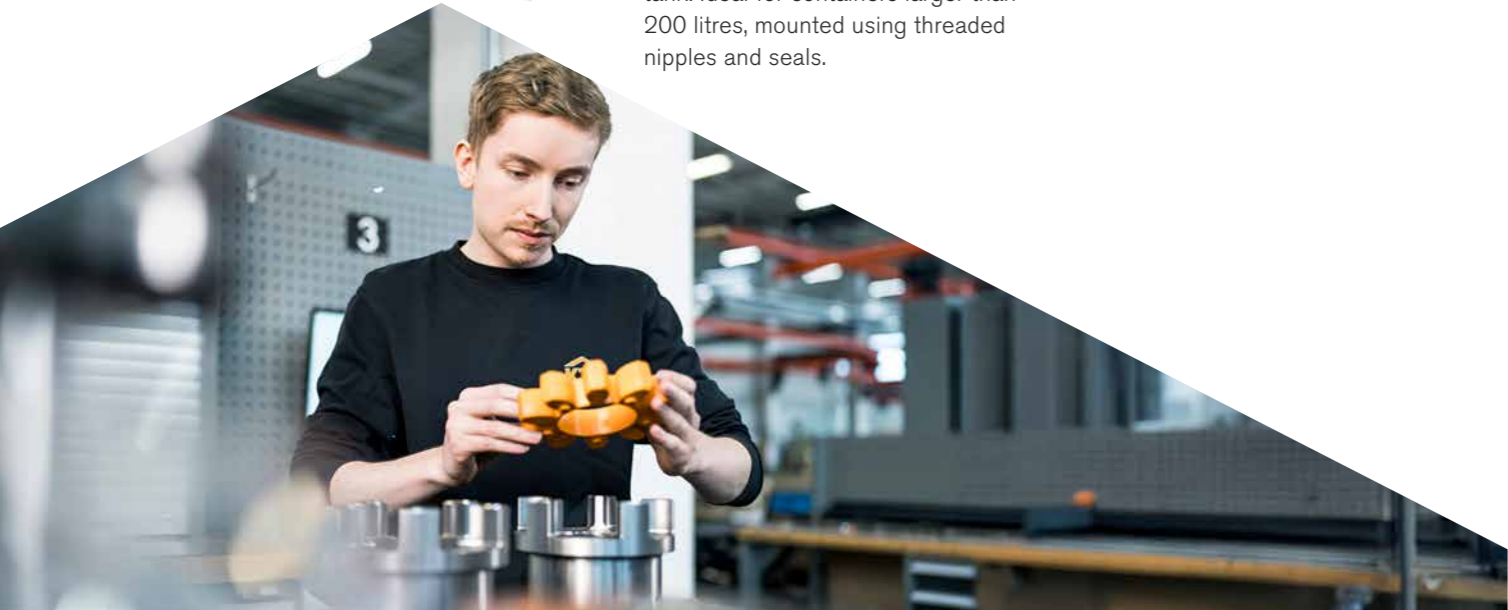
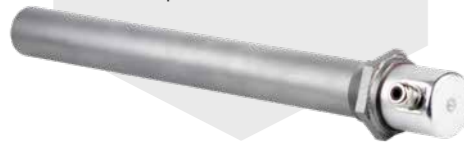

KTR FOCUS

⬡ **Servo hydraulics**

For demanding servo hydraulics, we offer an expanded standard range across the entire spectrum – accurately designed, high-quality processed and quickly available.



**Bellhousings
PSG**
for servo hydraulics

Cast bellhousing that was particularly developed for drives with servo motors which is the reason for the rectangular flange.

- _____ Flange dimensions suitable for rectangular connection diagrams of servo motors
- _____ Good noise damping properties
- _____ Horizontal mounting in combination with KTR foot flanges possible
- _____ Available with venting hole and oil bleed or in oilproof design on request

Foot flange made of aluminium or nodular iron that allows horizontal mounting in combination with all bellhousings.

- _____ For bellhousings size 200 – 660
- _____ Heavy types for higher loads
- _____ Compact, space-saving design
- _____ Reduces warehousing to one motor only for horizontal and vertical mounting



**Foot flange
type PTFS**
made of aluminium
or nodular iron



ROTEX® GS
Backlash-free
servo coupling

Backlash-free servo coupling. The various hub versions and different kinds of Shore hardness provide the optimum coupling for each application in servo hydraulics.

- _____ Hub material made of aluminium or steel
- _____ Modular system with high variability
- _____ Easy assembly

⬡ **Components for noise reduction**
 Extensive tests are carried out in our R&D test centre to test and optimise the effectiveness of the damping elements.

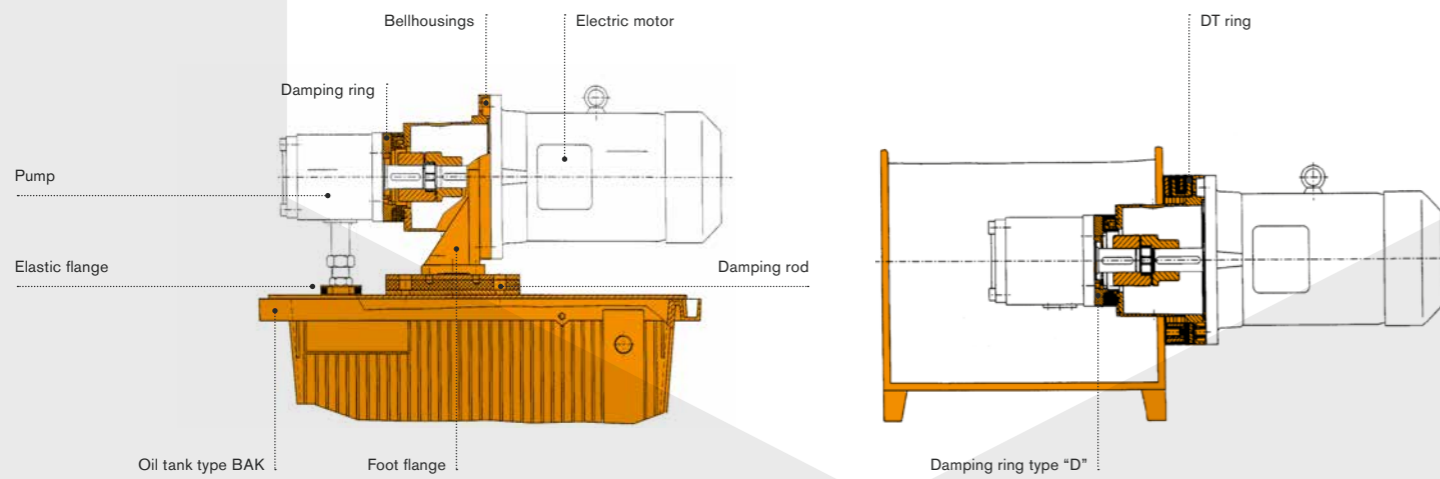

Examples of application: Potential noise reductions compared to the rigid arrangement:

- _ Damping ring only: 3 to 6 dBA
- _ Damping rod only: 3 to 4 dBA
- _ Damping ring and damping rod: 6 to 8 dBA
- _ Damping ring, damping rod and elastic flange: 7 to 10 dBA
- _ Damping ring type DT / DTV: 3 to 6 dBA
- _ Damping ring type DT / DTV and damping ring: 6 to 8 dBA

Damping rings
 for structure-borne noise separation



The damping rings offer a practical measure for structure-borne noise separation of the motor-pump-unit with vertical mounting.

High permissible radial, angular and axial loading capacity

Pressurized elastomer by bayonet inside parts (DT rings)

Integrated sealing lips for sealing to tank and bellhousing

Inner parts made of nodular iron (EN-GJS) for higher tightening torques (DTSV)

Our damping rods are an effective structure-borne noise separation of the motor-pump-unit with horizontal mounting on the tank.

No metallic connection between structure and substructure

Reinforce the substructure they are mounted on

Well-damping natural rubber (60Sh-A)

Reduce the structure-borne noise and lower the sound level

Damping rod
 for structure-borne noise separation



⬡ **Oil-water cooler**

If cooling water is available, the use of an oil-water cooler can have advantages in terms of energy efficiency. Oil-water coolers require much less installation space. They are also quiet because there is no fan running.

Soldered plate heat exchanger with a cooling capacity between 1 and 200 kW, made up of two end plates, specifically corrugated flow plates and four connections.

Operating temperature: -10 °C to +200 °C.
 Maximum permissible operating pressure: 10 bars, 30 bars
 Oil flow: 5 – 450 l/min
 Water flow: 5 – 250 l/min



TAK/TP
Oil-water cooler with tube bundle heat exchanger



Bundle of pipes heat exchanger with replaceable bundles of pipes that was developed for hydraulic systems and gearboxes. Cooling capacity: 3 to 500 kW.

Easy to clean
 Tube bundle can be replaced
 Seawater versions available
 Oil flow: 5 – 1,300 l/min
 Water flow: 5 – 800 l/min

⬡ **Cooling of gear oil**

Due to their compact, robust and flexible design, the OPC and OPC2 series are ideal for cooling and filtering medium-sized and large gearboxes.

OPC
Oil-air coolers



Compact cooling unit with integrated pump. The flexible design of the series allows to use different pumps or motors.

2 to 110 kW cooling capacity
 5 to 170 l/min oil volume flow
 Drive motor 230/400V 50Hz and 460V 60Hz, special voltages on request
 Optionally available with filter
 Pump with pressure relief valve

Efficient gearbox cooling with with a separately switchable cooler motor. The cooling unit is designed as a modular system and offers great freedom in the selection of components.

2 to 110 kW cooling capacity
 5 to 141 l/min oil volume flow
 Drive motor 230 / 400V 50Hz and 460V 60Hz, special voltages on request
 Modular system with high flexibility

OPC2
Oil-air cooler with separately switchable cooler motor

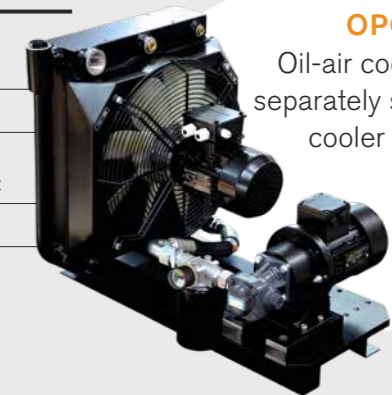

CS-PHE
Oil-water cooler with plate heat exchanger and integrated pump



The modular cooling pump unit consists of a plate heat exchanger, a pump and an electric motor, and is optionally available with filtration.

Plate heat exchanger in four sizes
 Kracht pump in 20 sizes with a flow rate of 5 to 200 litres per minute
 Suitable electric motors with corresponding power output
 Components can be individually customised





On our website
www.ktr.com/en



Products



Cooling systems



Oil-air coolers
you can find more information.

⬡ Cooling for marine applications

Harsh and salty environmental conditions require special preparations for painting, connecting elements, seals, etc.

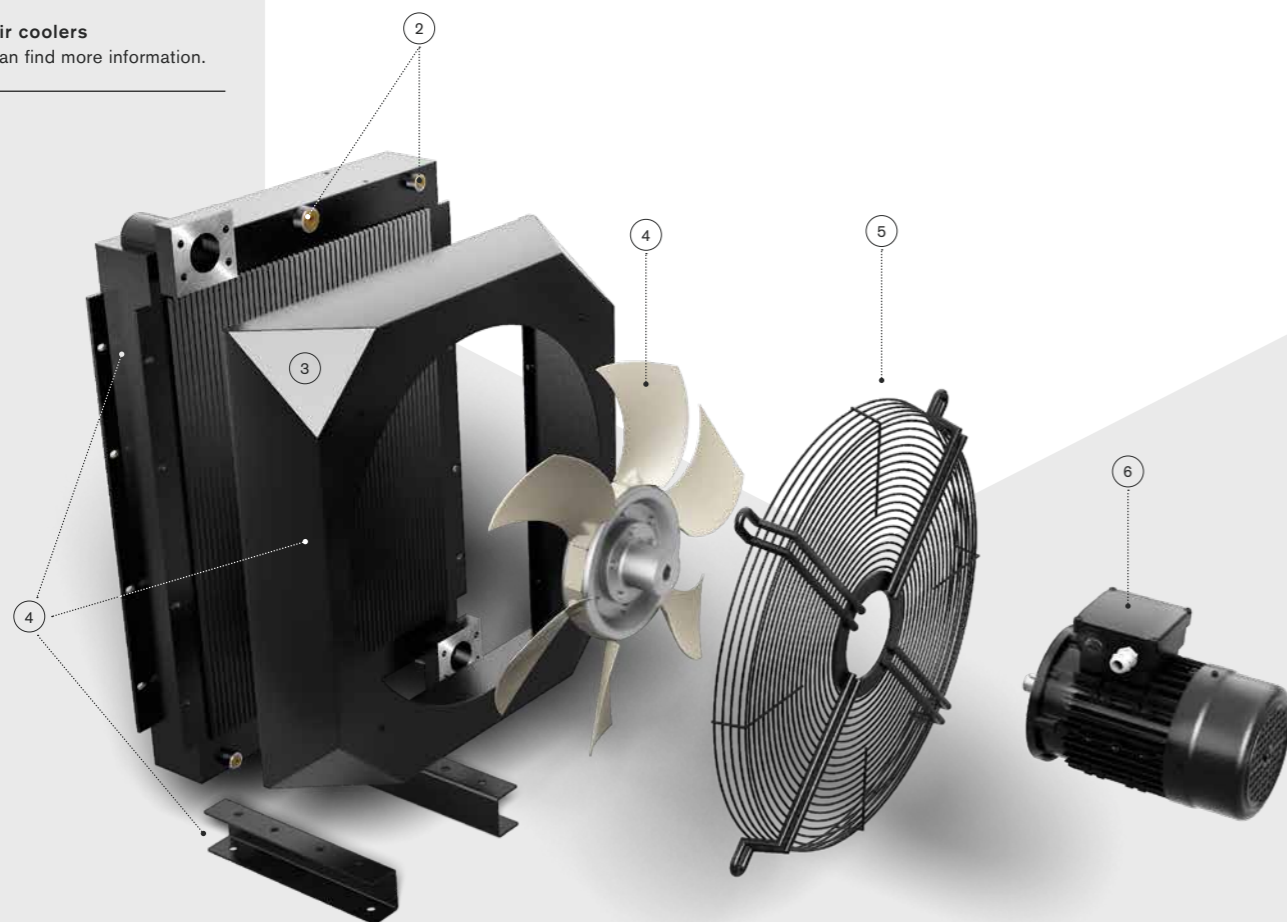

- ① Cooling element, cover, motor bracket and feet – covered with sea air resistant paint – salt mist spray test up to 1,440 hours (DIN ISO 9227)
- ② Connection elements made of stainless steel (A4)
- ③ Noise-reducing fan cover
- ④ Fan wheel in C4 version
- ⑤ Protective grid with PA coating

- ⑥ Features of motor:
 - _ Protection class IP56
 - _ Cast iron housing
 - _ C4 paint (C5 on request)
 - _ Internal primer coating (Engine and junction box)
 - _ Standstill heating



On our website
www.ktr.com/en



Services & Tools



Certificates



ATEX Explosion Protection
you can find more information.

⬡ ATEX

Hydraulic oil cooler in ATEX design for use in potentially explosive atmospheres.

In accordance with the European Directive 2014/34/EU, known as ATEX, we have had key series in our overall range tested by an independent institute with regard to their suitability for use in potentially explosive atmospheres. Our explosion protection brochure explains the ATEX requirements in detail and presents the KTR products for potentially explosive areas with their most important properties and their explosion protection labelling.



Our oil-air coolers in the OAC, OPC and OPC2 series are **approved with the following certifications:**

⊕ II 2 G Ex h IIC T6...T3 Gb X
⊕ II 3 D Ex h IIIIC T68°C...110°C Dc X
-40°C ≤ T_a ≤ +55°C



To ensure that all individual components are conductively connected to each other, copper strips and fan discs are also used in the ATEX version; their conductivity is checked at the end of assembly for each ATEX cooler.

www.ktr.com/
de/en/industries

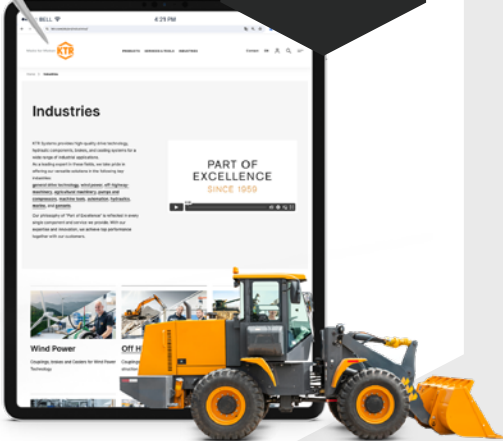

Solutions across all industries on our KTR website.

KTR Systems supplies high-quality products for a wide range of industrial applications. We are proud to be able to offer versatile solutions across all key industries with our drive technology, hydraulic components, brakes and cooling systems.

No matter what industry you need components for, we look forward to supporting you with our expertise and innovative strength to meet your challenges. Achieve peak performance with us! Find out more about the diversity of our portfolio on our website:

www.ktr.com

Get in touch with us.

We are your direct link! You are in the right spot for questions, suggestions or criticism. No matter which way you choose, we are here to answer your questions!



Your direct contact. Find the right contact person in your country. Please send us an e-mail. We will get back to you. → mail@ktr.com

Follow us also digitally for the latest innovations, trends and information about KTR on the following channels:



or at www.ktr.com



Headquarters KTR Systems GmbH

Carl-Zeiss-Straße 25
48432 Rheine, Germany
P: +49 5971 798 - 0
F: +49 5971 798 - 698 or 798 - 450
mail@ktr.com, www.ktr.com

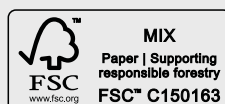

Made for Motion

