

ROTEX® GS P

Torsionally flexible jaw couplings

according to directive 2014/34/EU and UK directive SI 2016 No. 1107

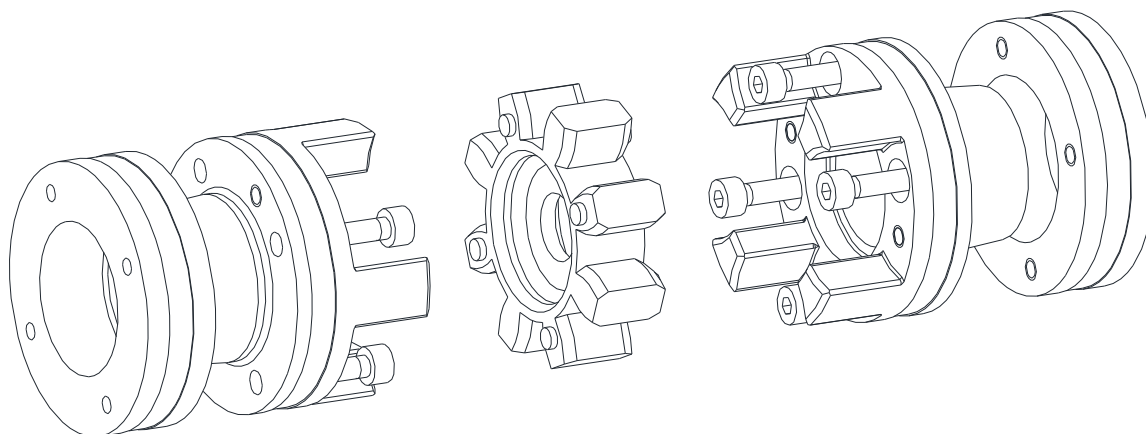



ROTEX® GS P is a highly accurate plug-in shaft coupling for spindle drives in machine tools. It is able to compensate for shaft misalignment, for example caused by manufacturing inaccuracies, thermal expansion, etc.

Table of contents

1	Technical data	3
2	Advice	5
	2.1 General advice	5
	2.2 Safety and advice symbols	6
	2.3 General hazard warnings	6
	2.4 Intended use	6
	2.5 Coupling selection	7
	2.6 Reference to EC Machinery Directive 2006/42/EC	7
3	Storage, transport and packaging	7
	3.1 Storage	7
	3.2 Transport and packaging	7
4	Assembly	8
	4.1 Components of the coupling	8
	4.2 Advice for assembly	9
	4.3 Advice for finish bore	9
	4.4 Assembly of clamping ring hubs type 6.0	9
	4.5 Disassembly of clamping ring hubs type 6.0	11
	4.6 Assembly of the coupling	11
	4.7 Displacements - alignment of the couplings	11
5	Start-up	13
6	Breakdowns, causes and elimination	14
7	Disposal	16
8	Maintenance and service	17
9	Spares inventory, customer service addresses	17
10	Enclosure A	
	Advice and instructions regarding the use in potentially explosive atmospheres	18
	10.1 Intended use in potentially explosive atmospheres	18
	10.2 Inspection intervals for couplings in potentially explosive atmospheres	19
	10.3 Standard values of wear	20
	10.4 marking of couplings for potentially explosive atmospheres	21
	10.5 EU Declaration of conformity	23
	10.6 UK Declaration of conformity	24



1 Technical data

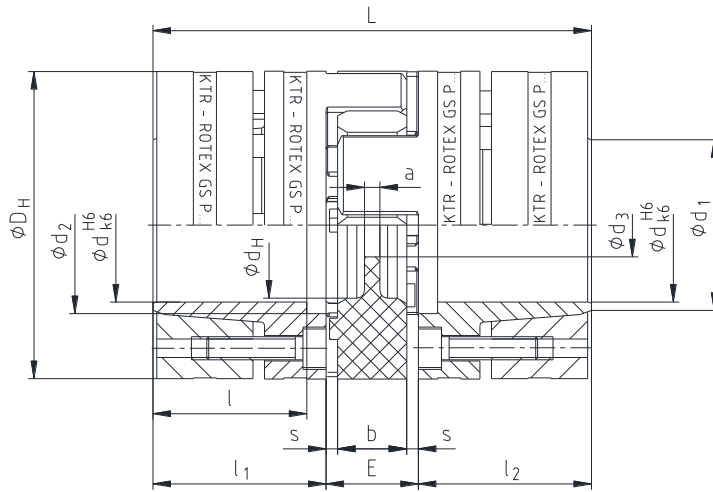

Extraction thread M between clamping screws.

Illustration 1: Dimensions

Table 1: Dimensions

Hub and clamping ring material - steel																
Size	Spider ¹⁾ (component 2) Rated torque [Nm]		Dimensions [mm]											Clamping screws DIN EN ISO 4762		
	98 ShA-GS	64 ShD-GS	d _{max.}	D _H ²⁾	d _H	L	l ₁ , l ₂	l	E	b	s	a	d ₃	M	z ³⁾	T _A [Nm]
14	12.5	16	15	32	10.5	50	18.5	15.5	13	10	1.5	2	-	M3	4	1.89
19	21	26	20	40	18	66	25	21	16	12	2	3	-	M4	6	3.05
24	60	75	28	55	27	78	30	25	18	14	2	3	-	M5	4	8.5
28	160	200	38	65	30	90	35	30	20	15	2.5	4	-	M5	8	8.5
38	325	405	48	80	38	114	45	40	24	18	3	4	-	M6	8	14
42	450	560	51	95	46	126	50	45	26	20	3	4	18.5	M8	4	35
48	525	655	55	105	51	140	56	50	28	21	3.5	4	20.5	M10	4	69
55	685	825	70	120	60	160	65	58	30	22	4	4.5	22.5	M10	4	69
65	940	1175	70	135	68	185	75	55	35	26	4.5	4.5	30	M12	4	120
75	1920	2400	80	160	80	210	85	63	40	30	5.0	5.0	40	M12	5	120
90	3600	4500	105	200	104	245	100	75	45	34	5.5	6.5	50	M16	5	295

- 1) For further spiders/selection of spider see catalogue Drive Technology „ROTEX® GS“.
- 2) Ø DH + 2 mm with high speeds for expansion of spider
- 3) z = Number each clamping ring hub

Table 2: Assignment for stub spindles according to DIN 69002

Hub and clamping ring material - steel												
Spindle drive	Size	Dimensions according to DIN 69002 [mm]								Tightening torque T _A [Nm]	Friction torque T _R with bore Ød* [Nm]	
		d*	d ₁	d ₂	d ₃	D _H ³⁾	l ₁ , l ₂	L	E			
25 x 20	14	14	17	17	8.5	32	18.5	50	13	1.89	25	
32k x 25	19 / 37.5	16	20	19	9.5	37.5	25	66	16	3.05	60	
32g x 30	19	19	23	22	9.5	40	25	66	16	3.05	71	
40 x 35	24 / 50	24	28	29	12.5	50	30	78	18	4.9	108	
50 x 45	24	25	30	30	12.5	55	30	78	18	8.5	170	
63 x 55	28	35	40	40	14.5	65	35	90	20	8.5	506	
80 x 75	38	40	46	46	16.5	80	45	114	24	14	821	

* standard spindle shaft diameter with tolerance H6/j5

1 Technical data

Table 3: Friction torque and surface pressure of ROTEX® GS P clamping ring hubs

Size	14	19	24	28	38	42	48	55	65	75	90
Bore Ø d	Transmittable friction torque T_R of clamping ring hub [Nm] surface pressure [N/mm ²]										
Ø10	11 93	34 204									
Ø11	13 93	41 202									
Ø14	29 124	75 232	79 191								
Ø15		90 240	95 200	128 199							
Ø16		68 160	70 130	150 205							
Ø19		104 174	110 144	225 218							
Ø20		119 179	126 149	177 154	247 164						
Ø24			134 110	278 169	386 178						
Ø25			149 113	307 172	426 181	389 165					
Ø28			201 122	341 152	475 161	433 147					
Ø30				403 157	560 165	512 151	672 171				
Ø32				366 125	511 133	464 120	762 170				
Ø35				461 131	641 139	585 127	945 177	920 147			
Ø38				528 128	644 118	586 108	957 152	929 126			
Ø40					733 122	669 111	1082 155	1055 129	1532 148		
Ø42					828 125	631 95	1033 134	1002 111	1465 128	1835 144	
Ø45					825 108	753 99	1219 138	1190 115	1731 132	2161 148	
Ø48						888 102	1423 141	1198 102	1750 117	2190 132	
Ø50						906 96	1296 119	1325 104	1931 119	2413 134	4046 186
Ø55*							1606 122	1388 90	2034 104	2551 117	4503 171
Ø60*								1743 95	2534 109	3161 122	5057 161
Ø65*								1722 80	2521 92	3158 104	6079 165
Ø70*								2088 83	3038 96	3789 107	6181 145
Ø80*										4421 96	7324 131
Ø90*											8398 119
Ø95*											9530 121
Ø100*											9892 114
Ø105*											11084 116

* From Ø55 tolerance G6/m6.

The transmittable friction torques of the clamping connection consider the max. fitting tolerance with shaft tolerance k6/bore H6, from Ø55 G6/m6. The friction torque is reduced with bigger fit clearance and use of a hollow shaft (see chapter 4.5).

The surface pressure of the clamping connection specified considers the minimum clearance with shaft fit k6/bore H6, from Ø55 G6/m6.



A calculation of the hollow shaft strength is necessary if hollow shafts are used (see chapter 4.4)!

Please observe protection note ISO 16016.	Drawn:	2022-07-06 Pz/Wb	Replacing:	KTR-N dated 2019-11-04
	Verified:	2022-08-08 Pz	Replaced by:	

2 Advice

The **ROTEX® GS P** coupling was developed for backlash-free power transmission and easy plug-in assembly. This backlash-free power transmission arises in the area of prestress (see illustration 2). The big concave surface contact results in a lower surface pressure on the involute tooth. Consequently the tooth can be overloaded many times over with no wear/deformation. Safe operation in the range of prestress is ensured, because the coupling operates according to the principle of positive-locking rubber spring prestress with high damping features. The star-shape coupling spider is inserted in the cams of the hubs which are machined specifically accurately with a small amount of prestress, resulting in the necessary backlash-free power transmission. The axial insertion force varies depending on the coupling size, different kinds of Shore hardness and production tolerances. The flexible teeth compensating for misalignment are radially supported in the internal diameter by a web. An external deformation is limited by the concave shape of the cams, ensuring smooth operation even with bigger masses to be accelerated (e. g. machine tables, articulated arms, etc.). The flexible spiders for the GS series are available in five different kinds of Shore hardness, injected in different colours, either as a torsionally soft or hard material.

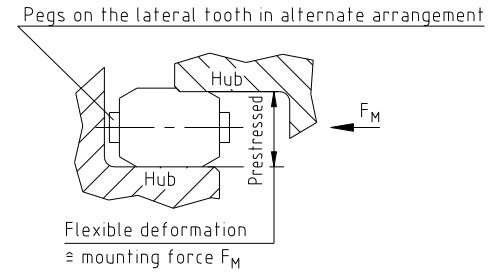

Illustration 2: Prestress of spider

2.1 General advice

Please read through these operating/assembly instructions carefully before you start up the coupling. Please pay special attention to the safety instructions!



The **ROTEX® GS P** coupling is suitable and approved for the use in potentially explosive atmospheres. When using the coupling in potentially explosive atmospheres, observe the special advice and instructions regarding safety in enclosure A.

In order to ensure the operating principle of **ROTEX® GS P** and avoid early wear of the coupling, a respective operating factor „S_B“ has to be considered with the selection, each depending on the application (see catalogue "Drive Technology"). Temperatures and shocks are provided with the corresponding factors, too (see catalogue "Drive Technology").

The operating/assembly instructions are part of your product. Please store them carefully and close to the coupling. The copyright for these operating/assembly instructions remains with KTR.



2 Advice

2.2 Safety and advice symbols



Warning of potentially explosive atmospheres

This symbol indicates notes which may contribute to preventing bodily injuries or serious bodily injuries that may result in death caused by explosion.



Warning of personal injury

This symbol indicates notes which may contribute to preventing bodily injuries or serious bodily injuries that may result in death.



Warning of product damages

This symbol indicates notes which may contribute to preventing material or machine damage.



General advice

This symbol indicates notes which may contribute to preventing adverse results or conditions.

2.3 General hazard warnings



With assembly, operation and maintenance of the coupling it has to be made sure that the entire drive train is secured against accidental switch-on. You may be seriously hurt by rotating parts. Make absolutely sure to read through and observe the following safety indications.

- All operations on and with the coupling have to be performed taking into account "safety first".
- Make sure to switch off the power pack before you perform your work on the coupling.
- Secure the power pack against accidental switch-on, e. g. by providing warning signs at the place of switch-on or removing the fuse for current supply.
- Do not reach into the operating area of the coupling as long as it is in operation.
- Secure the coupling against accidental contact. Provide for the necessary protection devices and covers.

2.4 Intended use

You may only assemble, operate and maintain the coupling if you

- have carefully read through the operating/assembly instructions and understood them
- are technically qualified and specifically trained (e. g. safety, environment, logistics)
- are authorized by your company

The coupling may only be used in accordance with the technical data (see chapter 1). Unauthorized modifications on the coupling design are not admissible. We will not assume liability for any damage that may arise. In the interest of further development we reserve the right for technical modifications.

The **ROTEX® GS P** described in here corresponds to the technical status at the time of printing of these operating/assembly instructions.

**2 Advice****2.5 Coupling selection**

For a long-lasting and failure-free operation of the coupling it must be selected according to the selection instructions (following DIN 740, part 2 with specific factors) for the particular application (see catalogue drive technology "ROTEX® GS"). If the operating conditions (performance, speed, modifications on engine and machine) change, the coupling selection must be reviewed. Make sure that the technical data regarding torque refer to the spider only. The transmittable torque of the shaft-hub-connection must be reviewed by the customer and is subject to his responsibility.

For drives subject to torsional vibrations (drives with cyclic stress due to torsional vibrations) it is necessary to perform a torsional vibration calculation to ensure a reliable selection. Typical drives subject to torsional vibrations are e. g. drives with diesel engines, piston pumps, piston compressors etc. If requested, KTR will perform the coupling selection and the torsional vibration calculation.

2.6 Reference to EC Machinery Directive 2006/42/EC

The couplings supplied by KTR should be considered as components, not machines or partly completed machines according to EC Machinery Directive 2006/42/EC. Consequently KTR does not have to issue a declaration of incorporation. For details about safe assembly, start-up and safe operation refer to the present operating/assembly instructions considering the warnings.

3 Storage, transport and packaging**3.1 Storage**

The coupling hubs are supplied in preserved condition and can be stored in a dry and roofed place for 6 - 9 months.

The features of the coupling spiders (elastomers) remain unchanged for up to 5 years with favourable storage conditions.



**The storage rooms must not include any ozone-generating devices like e. g. fluorescent light sources, mercury-vapour lamps or electrical high-voltage appliances.
Humid storage rooms are not suitable.
Make sure that condensation is not generated. The best relative air humidity is less than 65 %.**

3.2 Transport and packaging

In order to avoid any injuries and any kind of damage always make use of proper transport and lifting equipment.

The couplings are packed differently each depending on size, number and kind of transport. Unless otherwise contractually agreed, packaging will follow the in-house packaging specifications of KTR.



4 Assembly

The coupling is generally supplied in individual parts. Before assembly the coupling has to be inspected for completeness.

4.1 Components of the coupling

Features of standard spiders

Spider hardness (Shore)	Increasing hardness		
		98 Shore A-GS (red)	64 Shore D-H-GS (green)
Size	14 - 90	14 - 38	42 - 90
Material	Polyurethane	Hytrel	Polyurethane
Marking (colour)			

Components of ROTEX® GS P clamping ring hub

Component	Quantity	Description
1	2	Clamping ring
2	2	Clamping ring hub
3	1	Spider
4	see table 1	Cap screw DIN EN ISO 4762

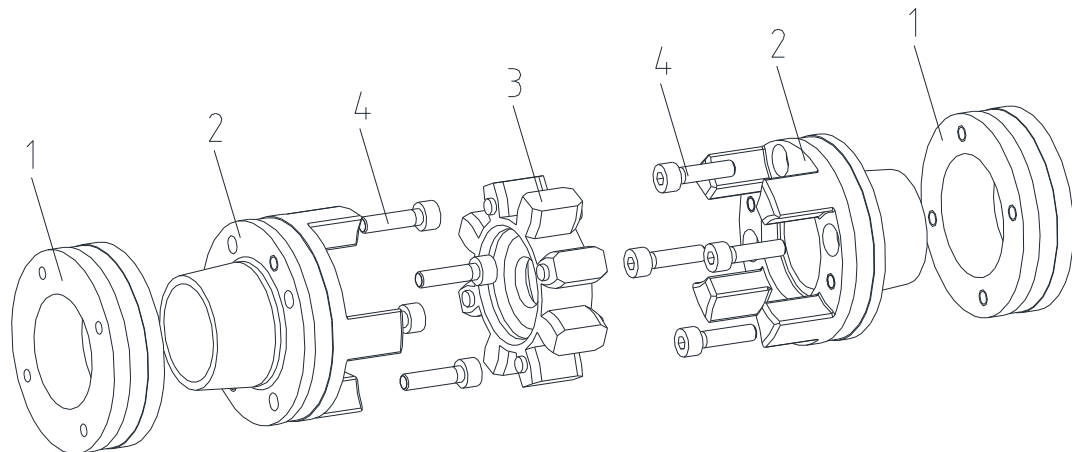

Illustration 3: ROTEX® GS P clamping ring hub



4 Assembly

4.2 Advice for assembly

Subject to its design the **ROTEX® GS P** allows to axially plug in the coupling after having assembled the hubs onto the shaft journal. Consequently there is no need for subsequent screwing and the respective mounting holes in the housing.

The pegs on the spider arranged reciprocally prevent a contact between the spider and the hubs over the full surface. Observing the distance dimension E, the ability for displacement of the coupling is ensured in this way. All teeth are chamfered on the face which allows for blind assembly. When the coupling hubs are pushed together with the **ROTEX® GS** spider an axial assembly force is generated resulting from the flexible prestress of the star-shape elastomer. This assembly force varies depending on the coupling size, spider hardness and machining tolerances.

The axial insertion force is offset after having pushed together the hubs and consequently does not mean any risk of axial load affecting adjacent bearings.

The mounting force can be reduced by lightly greasing or lubricating the elastomer or the hubs. For this purpose please only use oils and greases on a mineral oil basis without any additives. Lubricants on a silicone basis or vaseline have proven their worth, too.

4.3 Advice for finish bore



A subsequent modification of the finish bore by the customer is not permissible.



The customer bears the sole responsibility for all machining processes performed subsequently on finish machined coupling components and spare parts. KTR does not assume any warranty claims resulting from insufficient remachining.

4.4 Assembly of clamping ring hubs type 6.0

The power transmission of the **ROTEX® GS P** clamping ring hub is frictionally engaged. The necessary surface pressure is transmitted via the clamping ring with internal taper to the taper hub and consequently to the shaft. The friction torques specified in table 3 consider a fit pair H6/k6 from Ø55 G6/m6; with a bigger clearance the friction torques specified in table 3 are reduced.

The strength and dimensions of the shafts (specifically hollow shafts) have to be defined such that sufficient safety against plastic deformation is ensured. This may roughly be reviewed as per the following criterion.

For clamping connections with hollow shafts the required internal diameter of the hollow shaft d_{iW} is calculated based on the following formula:

$$d_{iW} \leq d \cdot \sqrt{\frac{R_{p0,2} - 2 \cdot p_W}{R_{p0,2}}} \quad [\text{mm}]$$

Shear stress on the internal shaft diameter for hollow shaft:

$$\sigma_{tW} \approx - \frac{2 \cdot p_W}{1 - C_W^2} \quad [\text{N/mm}^2]$$

Shear stress for solid shaft:

$$\sigma_{tW} = - p_W \quad [\text{N/mm}^2]$$

$R_{p0,2}$ = yield strength of shaft material [N/mm²]
 p_W = surface pressure of hub/shaft [N/mm²]

d_{iW} = internal diameter of hollow shaft [mm]
 d = shaft diameter [mm]
 C_W = d_{iW} / d

4 Assembly

4.4 Assembly of clamping ring hubs type 6.0

The strength required is not provided if the hollow shaft bore is bigger than the max. internal bore calculated or if the shear stress exceeds the yield strength of the material.
 For a detailed calculation please contact KTR's engineering department.



We recommend to inspect bores and shafts for dimensional accuracy before assembly.



Please note the manufacturer's instructions regarding the use of detergents.



Please pay attention to the ignition risk in potentially explosive atmospheres!



If used in potentially explosive atmospheres all screw connections must be secured against working loose additionally, e. g. conglomerating with Loctite (average strength).

- Clean the hub bore and shaft and review for dimensional accuracy, afterwards lubricate with a thin oil (e. g. Castrol 4 in 1, Klüber Quietsch-Ex or WD-40).



Oils and greases containing molybdenum disulfide or other high-pressure additives as well as internal lubricants must not be used.

- Lightly untighten the clamping screw and pull the clamping ring from the hub only marginally to make sure that the clamping ring is fitted loosely.
- Shift the clamping ring hub onto the shaft.
- Tighten the clamping screws evenly crosswise gradually to the tightening torque specified in table 1. Repeat this process until all clamping screws have reached the tightening torque.

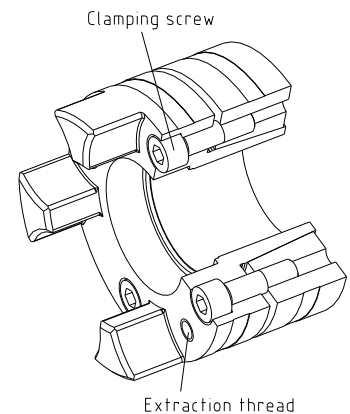

Illustration 4: Assembly of clamping ring hub with clamping ring



If the clamping screws are not tightened at the correct tightening torque, there is the risk of
 a) a fracture of the hub and plastic deformation with a too high tightening torque T_A
 b) early slipping, untightening of the screws with a too low tightening torque T_A

4 Assembly

4.5 Disassembly of clamping ring hubs type 6.0

Unscrew the clamping screws evenly one after another. During each revolution every screw may only be unscrewed by half a turn. Unscrew all clamping screws by 3 - 4 pitches.

Remove the screws located next to the extraction threads and screw them into the intended extraction threads until they fit.

The clamping ring is released by tightening the screws in the extraction threads evenly gradually and crosswise.



If these hints are not observed, the operation of the coupling may be affected.

If the assembly is repeated the bores of the hub and shafts have to be cleaned and afterwards lubricated with a thin oil (e. g. Castrol 4 in 1, Klüber Quietsch-Ex or WD-40). The same applies for the taper surfaces of clamping ring hub and clamping ring.

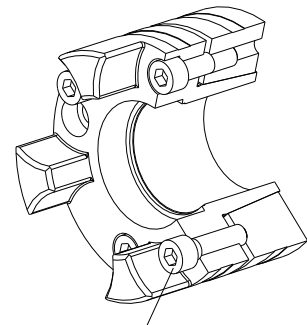

Clamping screw in extraction thread

Illustration 5: Disassembly of clamping ring hub with clamping ring



Oils and greases containing molybdenum disulfide or other high-pressure additives as well as internal lubricants must not be used.

4.6 Assembly of the coupling



With the assembly make sure that the distance dimension E (see table 1 and 2) is observed to allow for axial clearance of the spider when in operation. Disregarding this advice may cause damage to the coupling.

- Mount the clamping ring hubs on the shaft of driving and driven side (see chapter 4.4).
- Insert the spider into the cam section of the clamping ring hub on the driving or driven side.
- Shift the power packs in axial direction until the distance dimension E is achieved (see illustration 1).

4.7 Displacements - alignment of the couplings

The displacement figures specified in table 4 provide for sufficient safety to compensate for external influences like, for example, thermal expansion or foundation settling.



In order to ensure a long service life of the coupling and avoid hazards with the use in potentially explosive atmospheres, the shaft ends must be accurately aligned. Please absolutely observe the displacement figures specified (see table 4). If the figures are exceeded, the coupling will be damaged.



The more accurate the alignment of the coupling, the longer is its service life. If used in potentially explosive atmospheres for explosion group IIC, only half of the displacement figures (see table 4) are permissible.

Please note:

- The displacement figures specified in table 4 are maximum figures which must not arise in parallel. If radial and angular displacements arise simultaneously, the permissible displacement values may only be used proportionally (see illustration 7).
- Please inspect with a dial gauge, ruler or feeler gauge whether the permissible displacement figures specified in table 4 can be observed.

Please observe protection note ISO 16016.	Drawn: 2022-07-06 Pz/Wb Verified: 2022-08-08 Pz	Replacing: KTR-N dated 2019-11-04 Replaced by:
---	--	---

4 Assembly

4.7 Displacements - alignment of the couplings

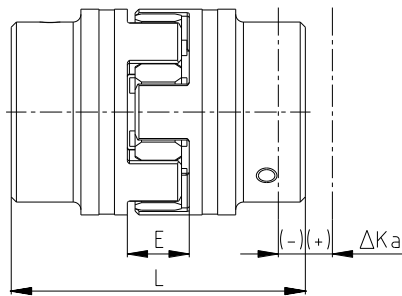

Axial displacements

$$L_{max} = L \pm \Delta K_a$$

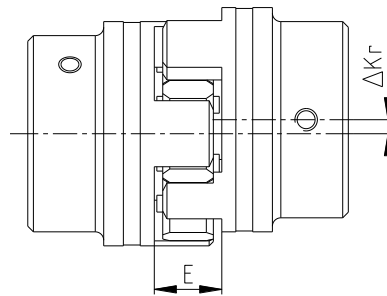

Radial displacements

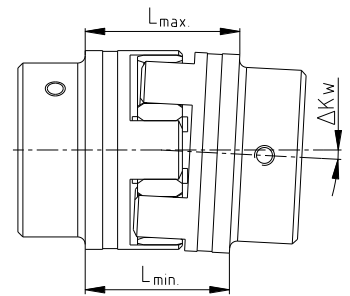

Angular displacements

$$\Delta K_w \text{ [mm]} = L_{1max} - L_{1min}$$

Illustration 6: Displacements

Examples of the displacement combinations specified in illustration 7:

Example 1:
 $\Delta K_r = 30 \%$
 $\Delta K_w = 70 \%$

Example 2:
 $\Delta K_r = 60 \%$
 $\Delta K_w = 40 \%$

$$\Delta K_{total} = \Delta K_r + \Delta K_w \leq 100 \%$$

Illustration 7: Combinations of displacement

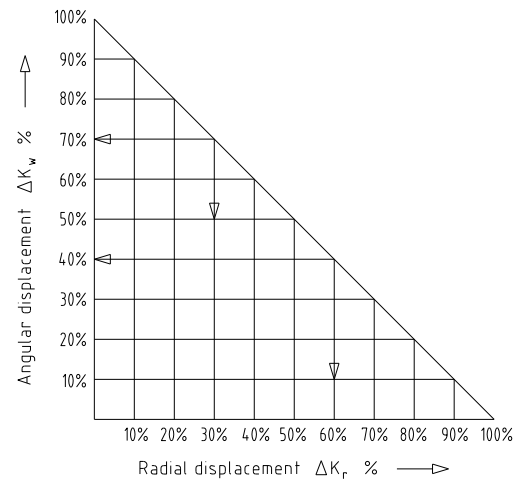

Table 4: Displacement figures

Size	Max. axial displacement ΔK_a [mm]	Max. radial displacement ΔK_r [mm]		Max. angular displacement ΔK_w [degree/mm]			
		98 ShA-GS ¹⁾	64 ShD-GS ¹⁾	98 ShA-GS ¹⁾		64 ShD-GS ¹⁾	
				Degree	mm	Degree	mm
14	+1.0 / -0.5	0.09	0.06	0.9	0.50	0.8	0.40
19	+1.2 / -0.5	0.06	0.04	0.9	0.60	0.8	0.55
24	+1.4 / -0.5	0.10	0.07	0.9	0.85	0.8	0.75
28	+1.5 / -0.7	0.11	0.08	0.9	1.00	0.8	0.90
38	+1.8 / -0.7	0.12	0.09	0.9	1.25	0.8	1.10
42	+2.0 / -1.0	0.14	0.10	0.9	1.50	0.8	1.30
48	+2.1 / -1.0	0.16	0.11	0.9	1.65	0.8	1.45
55	+2.2 / -1.0	0.17	0.12	0.9	1.85	0.8	1.70
65	+2.6 / -1.0	0.18	0.13	0.9	2.10	0.8	1.90
75	+3.0 / -1.5	0.21	0.15	0.9	2.50	0.8	2.20
90	+3.4 / -1.5	0.23	0.17	0.9	3.10	0.8	2.80

1) For further spiders/displacement figures of spiders refer to catalogue Drive Technology „ROTEX® GS“.

The permissible displacement figures of the flexible **ROTEX® GS P** couplings specified are general standard values considering the load of the coupling up to the rated torque T_{KN} of the coupling and an ambient temperature of +30 °C.

**5 Start-up**

Before start-up of the coupling, inspect the alignment and the distance dimension E and adjust, if necessary, and also inspect all screw connections for the tightening torques specified.



If used in potentially explosive atmospheres all screw connections must be secured against working loose additionally, e. g. conglutinating with Loctite (average strength).

Finally the coupling protection against accidental contact must be fitted. It is required in accordance with DIN EN ISO 12100 (Safety of Machinery) and directives 2014/34/EU and SI 2016 No. 1107 and must protect against

- access with the little finger
- falling down of solid foreign objects.

The coupling protection is not part of KTR's scope of delivery and is the customer's responsibility. It must have sufficient distance to the rotating components to avoid contact safely. Depending on the outside diameter DH of the coupling, we recommend the following minimum distance:

ØDH to 50 mm = 6 mm, ØDH 50 mm to 120 mm = 10 mm, ØDH from 120 mm = 15 mm.

Please check if a proper enclosure (ignition protection, coupling protection, contact protection) has been mounted and the operation of the coupling is not affected by the enclosure. The same applies for test runs and rotational direction inspections.

The cover may provide for openings intended for necessary heat dissipation. These openings have to comply with DIN EN ISO 13857.

The cover must be electrically conductive and included in the equipotential bonding. Bellhousings (magnesium share below 7.5 %) made of aluminium and damping rings (NBR) can be used as connecting element between pump and electric motor. The cover may only be taken off with standstill of the unit.



If the couplings are used in locations subject to dust explosion and in mining the user must make sure that there is no accumulation of dust in a dangerous volume between the cover and the coupling. The coupling must not operate in an accumulation of dust.

For covers with unlocked openings on the top face no light metals must be used if the couplings are used as equipment of equipment group II (*if possible, from stainless steel*). If the couplings are used in mining (equipment group I M2), the cover must not be made of light metal. In addition, it must be resistant to higher mechanical loads than with use as equipment of equipment group II.

During operation of the coupling, please pay attention to

- different operating noise
- vibrations occurring.



If you note any irregularities with the coupling during operation, the drive unit must be switched off immediately. The cause of the breakdown must be specified by means of the table „Breakdowns“ and, if possible, be eliminated according to the proposals. The potential breakdowns specified can be hints only. To find out the cause all operating factors and machine components must be considered.



5 Start-up

Coating of coupling:



If coated (priming, paintings, etc.) couplings are used in potentially explosive atmospheres, the requirements on conductivity and coating thickness must be considered. With paintings up to 200 µm electrostatic load does not have to be expected. If thicker paintings resp. coatings up to a layer thickness of a maximum of 2.0 mm are applied, the couplings are not permissible for gases and vapours of category IIC in potentially explosive areas, but only for gases and vapours of category IIA and IIB.

This also applies for multiple coatings exceeding an overall thickness of 200 µm. Make sure with painting or coating that the coupling components are conductively connected with the device/devices to be connected so that the equipotential bonding is not impeded by the paint or coat applied. Basically painting of the spider is not admitted to ensure an equipotential bonding.

In addition, make sure that the marking of the coupling remains legible.

6 Breakdowns, causes and elimination

The failures specified below can lead to a use of the **ROTEX® GS P** coupling other than intended. In addition to the specifications given in these operating/assembly instructions make sure to avoid such failures.

The errors listed can only be clues to search for the failures. When searching for the failure the adjacent components must generally be considered.



The coupling can become a source of ignition with improper use.

Directive 2014/34/EU and UK directive SI 2016 No. 1107 require special care by the manufacturer and the user.

General failures with use other than intended:

- Important data for the coupling selection are not forwarded.
- The calculation of the shaft-hub-connection is not considered.
- Coupling components with damage occurred during transport are assembled.
- If the heated hubs are assembled, the permissible temperature is exceeded.
- The clearance of the components to be assembled is not coordinated with one another.
- Tightening torques have been fallen below/exceeded.
- Components are mixed up by mistake/assembled incorrectly.
- A wrong or no spider is inserted in the coupling.
- No original **KTR** components (purchased parts) are used.
- Old/already worn out spiders or spiders stored for too long are used.
- Maintenance intervals are not observed.



6 Breakdowns, causes and elimination

Breakdowns	Causes	Hazard notes for potentially explosive atmospheres	Elimination
Different operating noise and/or vibrations occurring	Misalignment	Increased temperature on the spider surface; ignition risk by hot surfaces	<ol style="list-style-type: none"> 1) Set the unit out of operation 2) Eliminate the reason for the misalignment (e. g. loose foundation bolts, fracture of the engine mount, heat expansion of unit components, modification of the installation dimension E of the coupling) 3) For inspection of wear see chapter 10.2
	Wear of spider, short-term torque transmission due to metal contact	Ignition risk due to sparking	<ol style="list-style-type: none"> 1) Set the unit out of operation 2) Disassemble the coupling and remove residues of the spider 3) Inspect coupling components and replace coupling components that have been damaged 4) Insert spider, assemble coupling components 5) Inspect alignment, adjust if necessary
	Screws for axial fastening of hubs working loose	Ignition risk due to hot surfaces and sparking	<ol style="list-style-type: none"> 1) Set the unit out of operation 2) Inspect alignment of coupling 3) Tighten the screws to fasten the hubs and secure against working loose 4) For inspection of wear see chapter 10.2
Breaking of cams	Wear of spider, torque transmission due to metal contact	Ignition risk due to sparking	<ol style="list-style-type: none"> 1) Set the unit out of operation 2) Replace complete coupling 3) Inspect alignment
	Fracture of the cams due to high impact energy/overload		<ol style="list-style-type: none"> 1) Set the unit out of operation 2) Replace complete coupling 3) Inspect alignment 4) Find out the reason for overload
	Operating parameters do not meet with the performance of the coupling		<ol style="list-style-type: none"> 1) Set the unit out of operation 2) Review the operating parameters and select a bigger coupling (consider mounting space) 3) Assemble new coupling size 4) Inspect alignment
	Operating error of the unit		<ol style="list-style-type: none"> 1) Set the unit out of operation 2) Replace complete coupling 3) Inspect alignment 4) Instruct and train the service staff
Early wear of spider or reverse backlash	Misalignment	Increased temperature on the spider surface; ignition risk by hot surfaces	<ol style="list-style-type: none"> 1) Set the unit out of operation 2) Eliminate the reason for the misalignment (e. g. loose foundation bolts, fracture of the engine mount, heat expansion of unit components, modification of the installation dimension E of the coupling) 3) For inspection of wear see chapter 10.2
	e. g. contact with aggressive liquids/oils, ozone influence, too high/low ambient temperatures etc. causing physical modification of the spider	Ignition risk due to sparking with metallic contact of the cams	<ol style="list-style-type: none"> 1) Set the unit out of operation 2) Disassemble the coupling and remove residues of the spider 3) Inspect coupling components and replace coupling components that have been damaged 4) Insert spider, assemble coupling components 5) Inspect alignment, adjust if necessary 6) Make sure that further physical modifications of the spider are excluded

**6 Breakdowns, causes and elimination**

Breakdowns	Causes	Hazard notes for potentially explosive atmospheres	Elimination
Early wear of spider or reverse backlash	Ambient/contact temperatures which are too high for the spider, max. permissible -30 °C/+90 °C	Ignition risk due to sparking with metallic contact of the cams	<ol style="list-style-type: none"> 1) Set the unit out of operation 2) Disassemble the coupling and remove residues of the spider 3) Inspect coupling components and replace coupling components that have been damaged 4) Insert spider, assemble coupling components 5) Inspect alignment, adjust if necessary 6) Inspect and adjust ambient/contact temperature (correct by using other spider materials, if necessary)
Early wear of spider (liquefaction of material inside the spider cam)	Vibrations of drive		<ol style="list-style-type: none"> 1) Set the unit out of operation 2) Disassemble the coupling and remove residues of the spider 3) Inspect coupling components and replace coupling components that have been damaged 4) Insert spider, assemble coupling components 5) Inspect alignment, adjust if necessary 6) Find out the reason for the vibrations (possibly corrective by spider with lower or higher Shore hardness)



When operating with a worn spider (see chapter 10.3) proper operation is not ensured.

7 Disposal

In respect of environmental protection we would ask you to dispose of the packaging resp. products on termination of their service life in accordance with the legal regulations resp. standards that apply.

- **Metal**
Any metal components have to be cleaned and disposed of by scrap metal.
- **Nylon materials**
Nylon materials have to be collected and disposed of by a waste disposal company.



8 Maintenance and service

ROTEX® GS P is a low-maintenance coupling. We recommend to perform a visual inspection on the coupling **at least once a year**. Please pay special attention to the condition of the coupling spiders.

- Since the flexible machine bearings of the driving and driven side settle during the course of load, inspect the alignment of the coupling and re-align the coupling, if necessary.
- The coupling components have to be inspected for damages.
- The screw connections have to be inspected visually.



With the use in potentially explosive atmospheres observe chapter 10.2 "Inspection intervals for couplings in  potentially explosive atmospheres".

9 Spares inventory, customer service addresses

We recommend to store major spare parts on site to ensure the readiness for use of the machine in case if a coupling fails.

Contact addresses of the KTR partners for spare parts and orders can be obtained from the KTR homepage at www.ktr.com.



KTR does not assume any liability or warranty for the use of spare parts and accessories which are not provided by KTR and for the damages which may incur as a result.

KTR Systems GmbH
Carl-Zeiss-Str. 25
D-48432 Rheine
Phone: +49 5971 798-0
E-mail: mail@ktr.com

Please observe protection note ISO 16016.	Drawn: 2022-07-06 Pz/Wb	Replacing: KTR-N dated 2019-11-04
	Verified: 2022-08-08 Pz	Replaced by:

10 Enclosure A

Advice and instructions regarding the use in  potentially explosive atmospheres

Applicable hub type:

- 6.0 Precision clamping ring hub P

10.1 Intended use in potentially explosive atmospheres

Conditions of operation in potentially explosive atmospheres

The **ROTEX® GS P** couplings are suitable for the use according to directives 2014/34/EU and SI 2016 No. 1107.

- Protection against hazards arising from lightning must follow the lightning protection concept of the machine or plant. The relevant regulations and policy for lightning protection must be observed.
- The equipotential bonding of the couplings is made by metal contact between coupling hub and shaft. This equipotential bonding must not be affected.

1. Industry (with the exception of mining)

- Equipment group II of category 2 and 3 (*coupling is not approved/not suitable for equipment group 1*)
- Substance group G (*gases, fogs, vapours*), zone 1 and 2 (*coupling is not approved/not suitable for zone 0*)
- Substance group D (*dusts*), zone 21 and 22 (*coupling is not approved/not suitable for zone 20*)
- Explosion group IIC (*gases, fogs, vapours*) (*explosion groups IIA and IIB are included in IIC*) and explosion group IIIC (*dusts*) (*explosion groups IIIA and IIIB are included in IIIC*)

Temperature class:

Temperature class	PUR / Hytre!®	
	Ambient or operating temperature T _a ¹⁾	Max. surface temperature ²⁾
T4	-30 °C to +90 °C	+110 °C
T5	-30 °C to +75 °C	+95 °C
T6	-30 °C to +60 °C	+80 °C

Explanation:

The maximum surface temperatures each result from the maximum permissible ambient or operating temperature T_a plus the maximum temperature increase ΔT of 20 K to be considered. For the temperature class a safety margin subject to standard of 5 K is added.

- 1) The ambient or operating temperature T_a is limited to +90 °C due to the permissible permanent operating temperature of the elastomers used.
- 2) The maximum surface temperature of +110 °C applies for the use in locations which are potentially subject to dust explosion.

In potentially explosive atmospheres

- the ignition temperature of dusts generated must at least be 1.5 times the surface temperature to be considered
- the glow temperature must at least be the surface temperature to be considered plus a safety distance of 75 K.
- the gases and vapours generated must amount to the temperature class specified.

2. Mining

Equipment group I of category M2 (*coupling is not approved/not suitable for equipment group M1*).
Permissible ambient temperature -30 °C to +90 °C.

Please observe protection note ISO 16016.	Drawn: 2022-07-06 Pz/Wb	Replacing: KTR-N dated 2019-11-04
	Verified: 2022-08-08 Pz	Replaced by:



10 Enclosure A

Advice and instructions regarding the use in  potentially explosive atmospheres

10.2 Inspection intervals for couplings in  potentially explosive atmospheres

Equipment category	Inspection intervals
M2 2G 2D No gases and vapours of explosion group IIC	An inspection of the torsional backlash and a visual inspection of the flexible spider must be performed after 3,000 operating hours for the first time, at the latest after 6 months after start-up of the coupling. If you note insignificant or no wear on the spider upon this initial inspection, further inspections can each be performed after 6,000 operating hours or at the latest after 18 months, provided that the operating parameters remain the same. If you note significant wear during the initial inspection so that it would be recommendable to replace the spider, please find out the cause according to the table „Breakdowns“, if possible. The maintenance intervals must be adjusted to the modified operating parameters without fail.
M2 2G 2D Gases and vapours of explosion group IIC	An inspection of the torsional backlash and a visual inspection of the flexible spider must be performed after 2,000 operating hours for the first time, at the latest after 3 months after start-up of the coupling. If you note insignificant or no wear on the spider upon this initial inspection, further inspections can each be performed after 4,000 operating hours or at the latest after 12 months, provided that the operating parameters remain the same. If you note significant wear during the initial inspection so that it would be recommendable to replace the spider, please find out the cause according to the table „Breakdowns“, if possible. The maintenance intervals must be adjusted to the modified operating parameters without fail.

ROTEX® GS P backlash-free shaft couplings

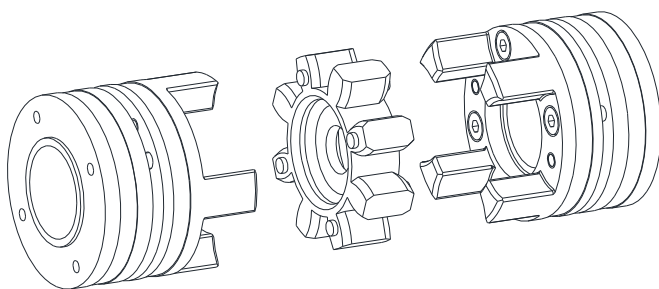

Illustration 8: ROTEX® GS P backlash-free shaft coupling

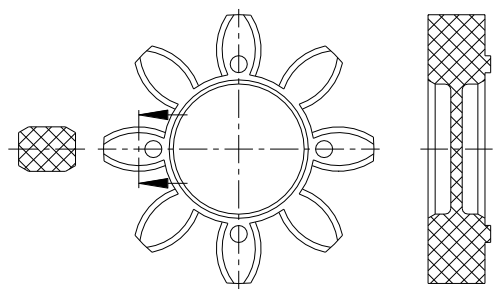

Illustration 9: ROTEX® GS spider

If the drive allows for, backlash between the cams of the coupling and the flexible spider has to be measured by means of a feeler gauge.
When reaching the wear limit **maximum friction**, the spider must be replaced immediately, irrespective of the inspection intervals.

Please observe protection note ISO 16016.	Drawn:	2022-07-06 Pz/Wb	Replacing:	KTR-N dated 2019-11-04
	Verified:	2022-08-08 Pz	Replaced by:	



10 Enclosure A

Advice and instructions regarding the use in  potentially explosive atmospheres

10.3 Standard values of wear

In case of backlash > X mm, the flexible spider must be replaced.

Monitoring of the general condition of the coupling can be done both at standstill and during operation. If the coupling is tested during operation, the operator must ensure an appropriate and proven test procedure (e. g. stroboscopic lamp, high-speed camera, etc.) which is definitely comparable to testing at standstill. If any distinctive features occur, an inspection must be made with the machine stopped.

Reaching the limits for replacing depends on the operating conditions and the existing operating parameters.



In order to ensure a long service life of the coupling and avoid hazards with the use in potentially explosive atmospheres, the shaft ends must be accurately aligned. Please absolutely observe the displacement figures specified (see table 4). If the figures are exceeded, the coupling will be damaged.

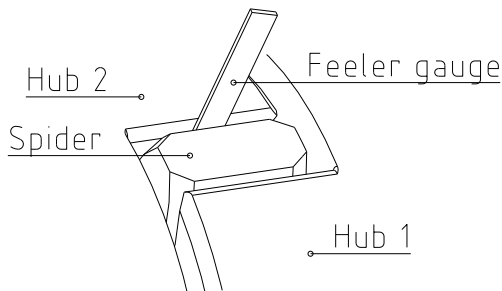

Illustration 10: Inspection of the limit of wear

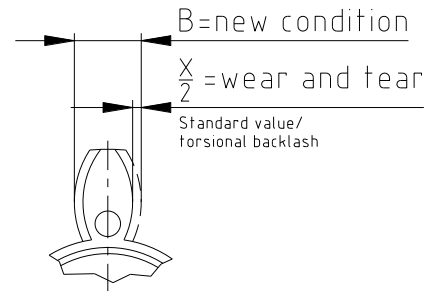

Illustration 11: Wear of spider



For backlash-free applications no wear is permitted, since otherwise the operating principle of the coupling (backlash-free condition) is no longer ensured. If a backlash-free operation is not required, the following figures apply:

Table 5:

Size	Limits of wear (friction)		Size	Limits of wear (friction)	
	$X_{max.}$ [mm]			$X_{max.}$ [mm]	
14	1.25		48	2.25	
19	0.9		55	2.50	
24	1.0		65	2.75	
28	1.4		75	3.00	
38	1.7		90	3.25	
42	2.0				



10 Enclosure A

Advice and instructions regarding the use in  potentially explosive atmospheres





10.4  marking of couplings for potentially explosive atmospheres

The explosion protection marking of the ROTEX® GS P coupling is applied on the outer sheath or on the front side.
The flexible spider is excluded.





For the complete marking refer to the operating/assembly instructions and/or the delivery note/package.

The following marking applies for the products:

- Type without aluminium, with feather keyway and/or clamping ring hub (Category 2)

    I M2 Ex h I Mb X
 II 2G Ex h IIC T6 ... T4 Gb X
 II 2D Ex h IIIC T80 °C ... T110 °C Db X
 <Year> -30 °C ≤ T_a ≤ +60 °C ... +90 °C
 KTR Systems GmbH, Carl-Zeiss-Str. 25, D-48432 Rheine

- Type with aluminium, with feather keyway and/or clamping ring hub (Category 2)

    II 2G Ex h IIC T6 ... T4 Gb X
 II 2D Ex h IIIC T80 °C ... T110 °C Db X
 <Year> -30 °C ≤ T_a ≤ +60 °C ... +90 °C
 KTR Systems GmbH, Carl-Zeiss-Str. 25, D-48432 Rheine

Short marking:

(A short marking is only made if not possible differently for reason of space or functioning.)

ROTEX® GS P
<Year>





Deviating marking applied until 31st October 2019:



Short marking:

  II 2GD c IIC T X/I M2 c X

Category 3:

  II 3G c IIC T6, T5 resp. T4 -30 °C ≤ T_a ≤ +65 °C, +80 °C resp. +90 °C
 II 3D c T 110 °C -30 °C ≤ T_a ≤ +90 °C

Complete marking:

  II 2G c IIC T6, T5 resp. T4 -30 °C ≤ T_a ≤ +65 °C, +80 °C resp. +90 °C
 II 2D c T 110 °C/I M2 c -30 °C ≤ T_a ≤ +90 °C

Please observe protection note ISO 16016.	Drawn:	2022-07-06 Pz/Wb	Replacing:	KTR-N dated 2019-11-04
	Verified:	2022-08-08 Pz	Replaced by:	

10 Enclosure A

Advice and instructions regarding the use in  potentially explosive atmospheres

10.4  marking of coupling for potentially explosive atmospheres

Comments on marking

Equipment group I	Mining
Equipment group II	Non-mining
Equipment category 2G	Equipment ensuring a high level of safety, suitable for zone 1
Equipment category 3G	Equipment ensuring a normal level of safety, suitable for zone 2
Equipment category 2D	Equipment ensuring a high level of safety, suitable for zone 21
Equipment category 3D	Equipment ensuring a normal level of safety, suitable for zone 22
Equipment category M2	Equipment ensuring a high level of safety must be able to be switched off when an explosive atmosphere occurs
D	Dust
G	Gases and vapours
Ex h	Nonelectrical explosion protection
IIC	Gases and vapours of class IIC (including IIA and IIB)
IIIC	Electrically conductive dusts of class IIIC (including IIIA and IIIB)
T6 ... T4	Temperature class to be considered, depending on the ambient temperature
T80 °C ... T110 °C	Maximum surface temperature to be considered, depending on the ambient temperature
-30 °C ≤ T _a ≤ +60 °C ... +90 °C or -30 °C ≤ T _a ≤ +90 °C	Permissible ambient temperature from -30 °C to +60 °C resp. -30 °C to +90 °C
Gb, Db, Mb	Equipment protection level, high level of safety, analogous to the equipment category
Gc, Dc	Equipment protection level, normal level of safety, analogous to the equipment category
X	For a safe use of the couplings particular conditions apply



10 Enclosure A

Advice and instructions regarding the use in  potentially explosive atmospheres

10.5 EU Declaration of conformity

EU Declaration of Conformity resp. Certificate of Conformity

corresponding to EU directive 2014/34/EU dated 26 February 2014
and to the legal regulations adopted for its implementation

The manufacturer - KTR Systems GmbH, Carl-Zeiss-Str. 25, D-48432 Rheine - states that the

ROTEX® GS P backlash-free shaft couplings

in an explosion-proof design described in these assembly instructions are equipment resp. components corresponding to article 2, 1. of directive 2014/34/EU and comply with the general safety and health specifications according to enclosure II of directive 2014/34/EU.

This declaration of conformity is issued under the sole responsibility of the manufacturers KTR Systems GmbH.

The coupling described in here complies with the specifications of the following standards/rules:

- EN ISO 80079-36:2016-12
- EN ISO 80079-37:2016-12
- EN ISO/IEC 80079-38:2017-10
- IEC/TS 60079-32-1:2020-01-24

The ROTEX® GS P is in accordance with the specifications of directive 2014/34/EU.

According to article 13 (1) b) ii) of directive 2014/34/EU the technical documentation is deposited with the notified body (type examination certificate IBExU03ATEXB002_05 X):

IBExU
Institut für Sicherheitstechnik GmbH
Identification number: 0637
Fuchsmühlenweg 7

09599 Freiberg

Rheine,
Place

2022-07-06
Date

i. V. 
Reinhard Wibbeling
Engineering/R&D

i. V. 
Johannes Deister
Product Manager



10 Enclosure A

Advice and instructions regarding the use in  potentially explosive atmospheres

10.6 UK Declaration of conformity

UK Declaration of Conformity resp. Certificate of Conformity

corresponding to UK directive SI 2016 No. 1107 dated 26 February 2014
and to the legal provisions adopted for its implementation

The manufacturer - KTR Systems GmbH, Carl-Zeiss-Str. 25, D-48432 Rheine - states that the

ROTEX® GS P backlash-free shaft couplings

in an explosion-proof design described in these assembly instructions are equipment resp. components corresponding to directive SI 2016 No. 1107 and comply with the general safety and health requirements according to directive SI 2016 No. 1107.

This declaration of conformity resp. certificate of conformity is issued under the sole responsibility of the manufacturer KTR Systems GmbH.

The coupling described in here complies with the specifications of the following standards/rules:

- EN ISO 80079-36:2016-12
- EN ISO 80079-37:2016-12
- EN ISO/IEC 80079-38:2017-10
- IEC/TS 60079-32-1:2020-01-24

The ROTEX® GS P is in accordance with the specifications respectively the applicable specifications of directive SI 2016 No. 1107.

According to directive SI 2016 No. 1107 the technical documentation is deposited with the notified body:

Eurofins CML
Identification number: 2503

Rheine,
Place

2022-07-06
Date

i. V. 
Reinhard Wibbeling
Engineering/R&D

i. V. 
Johannes Deister
Product Manager