

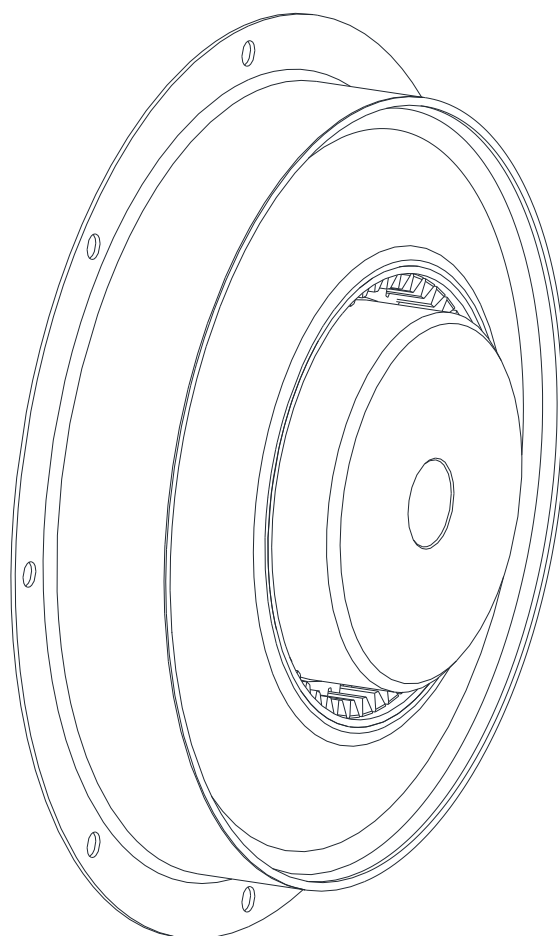



SINULASTIC®

highly flexible flange coupling type B



Type B

	SINULASTIC®	KTR-N 48711 EN
	Operating/Assembly instructions	Sheet: 2 of 14
	Type B	Edition: 1

SINULASTIC® type B is a highly torsionally flexible flange coupling easy to plug in axially with a linear torsional stiffness characteristic curve. It dampens torsional vibrations and compensates for axial, radial and angular shaft displacements.

Table of contents

1	Technical data	3
1.1	Coupling dimensions and technical data	3
2	Advice	5
2.1	General advice	5
2.2	Safety and advice symbols	5
2.3	General hazard warnings	5
2.4	Intended use	6
2.5	Coupling selection	6
2.6	Reference to EC Machinery Directive 2006/42/EC	6
3	Storage, transport and packaging	7
3.1	Storage	7
3.2	Transport and packaging	7
4	Assembly	8
4.1	Components of the couplings	8
4.2	Advice for finish bore	8
4.3	General advice for assembly	9
4.4	Assembly of the coupling	9
4.5	Displacements - alignment of the couplings	10
5	Start-up	12
6	Breakdowns, causes and elimination	12
7	Disposal	13
8	Maintenance and service	14
9	Spares inventory, customer service addresses	14

Please observe protection note ISO 16016.	Drawn: 2021-09-13 Shg/Mai	Replacing: ---
	Verified: 2021-09-16 Shg	Replaced by:



1 Technical data

1.1 Coupling dimensions and technical data

Type B

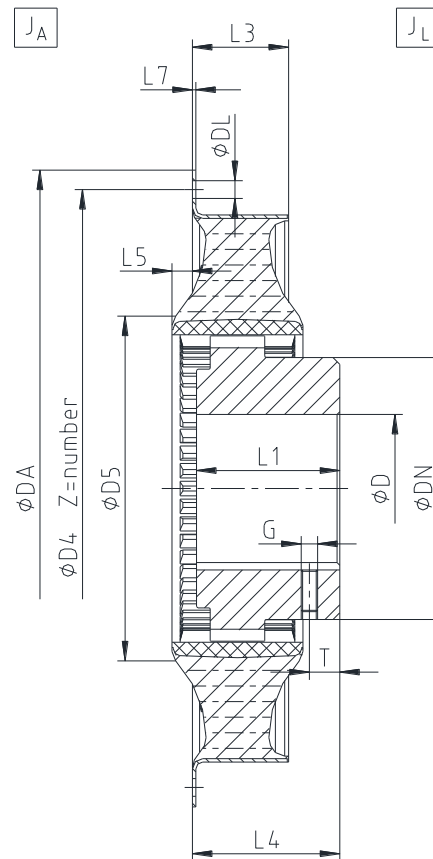

Illustration 1: SINULASTIC® type B

Table 1: Dimensions - type A

Size	Finish bore D [mm]		Flange connection acc. to SAE - J620/ diameter ¹⁾	Dimensions ³⁾ [mm]						
	Pilot bored	Max.		DN	D5	L1	L3	L4	L5	L7
20	-	80	11.5"	124	169	75	60	80.5 ±21	8.5	2.0
			14"							
38	-	125	14"	200	245	140	52	136 ±14	10	2.5
			18"							
			Ø475 ²⁾							
53	-	125	14"	200	247	140	70.5	143 ±20	15	2.5
			18"							
			Ø475 ²⁾							
140	-	240	21"	326	431	200	81	175 ±12	10	3
			24"							
180	-	240	21"	326	431	200	101	185 ±22	10	3
			24"							

1) For dimensions of flange connection see table 3.

2) Flange connection differing from SAE standard, dimensions in mm.

3) For dimensions G and T see table 5.



In case if a dimensional drawing was prepared for the coupling, the dimensions specified have to be primarily observed.

Please observe protection note ISO 16016.

Drawn: 2021-09-13 Shg/Mai

Replacing: ---

Verified: 2021-09-16 Shg

Replaced by:



1 Technical data

1.1 Coupling dimensions and technical data

Table 2: Technical data - type B

Size	Flange connection acc. to SAE - J620 / diameter ¹⁾	Total weight with maximum bore of coupling [kg]	Mass moment of inertia with maximum bore of coupling [kgm ²]	
			J _A	J _L
20	11.5"	9.71	0.0625	0.0338
	14"	10.85	0.1114	0.0338
38	14"	28.94	0.1524	0.2076
	18"	30.62	0.1578	0.2076
	Ø475 ²⁾	29.04	0.2655	0.2076
53	14"	30.85	0.1888	0.2280
	18"	32.52	0.1942	0.2280
	Ø475 ²⁾	30.95	0.302	0.2280
140	21"	83.57	0.8816	1.8812
	24"	85.10	1.0708	1.8812
180	21"	88.83	1.0905	2.0194
	24"	90.37	1.2796	2.0194

- 1) For dimensions of flange connection see table 3.
 2) Flange connection differing from SAE standard, dimensions in mm.

Table 3: Flange dimensions according to SAE J 620

Nominal size	Flange dimensions [mm]					
	11.5"	14"	18"	21"	24"	Ø475 ¹⁾
Dimension DA	352.42	466.72	571.50	673.10	733.42	475.00
Dimension D4	333.37	438.15	542.90	641.35	692.15	450.00
Number Z	8	8	6	12	12	12
Dimension DL	11	13	17	17	21	11

- 1) Flange connection differing from SAE standard, dimensions in mm.

Table 4: Torques

Size	Elastomer hardness	Torque [Nm]				Perm. operating speed n _{max} [rpm]
		T _{KN}	T _{K max}	T _{K max1}	T _{KW}	
20	S	1750	2625	5250	700	3600
	M	2000	3000	6000	800	3600
	H	2500	3,750	7500	1000	3800
38	S	3000	4500	9000	1200	3200
	M	3800	5700	11400	1520	3200
	H	4600	6900	13800	1840	3600
53	S	4000	6000	12000	1600	3000
	M	5300	7950	15900	2120	3000
	H	6200	9300	18600	2480	3400
140	S	12000	18000	36000	4800	2400
	M	14000	21000	42000	5600	2400
	H	16200	24300	48600	6480	2800
180	S	14600	21900	43800	5840	2400
	M	18000	27000	54000	7200	2400
	H	22000	33000	66000	8800	2600

Maximum torque of coupling T_{K max} = rated torque of coupling T_{KN} x 1.5.
 The maximum torque T_{K max} indicates short-term torque peaks (e.g. when passing through the resonance). T_{K max} may arise at the maximum 50,000 times as vibratory torque or 100,000 times as pulsating torque.

Triple the rated torque of coupling T_{K max1} = rated torque of coupling T_{KN} x ~3.0.

The triple rated torque T_{K max1} is the torque that may arise only rarely, but only 1,000 times at the maximum. Above the triple rated torque of T_{K max1} the coupling may be damaged each depending on the elastomer type and hardness.



2 Advice

2.1 General advice

Please read through these operating/assembly instructions carefully before you start up the coupling. Please pay special attention to the safety instructions! The operating/assembly instructions are part of your product. Please store them carefully and close to the coupling. The copyright for these operating/assembly instructions remains with KTR.

2.2 Safety and advice symbols



Warning of personal injury

This symbol indicates notes which may contribute to preventing bodily injuries or serious bodily injuries that may result in death.



Warning of product damages

This symbol indicates notes which may contribute to preventing material or machine damage.



General advice

This symbol indicates notes which may contribute to preventing adverse results or conditions.



Warning of hot surfaces

This symbol indicates notes which may contribute to preventing burns with hot surfaces resulting in light to serious bodily injuries.

2.3 General hazard warnings



With assembly, operation and maintenance of the coupling it has to be made sure that the entire drive train is secured against accidental switch-on. You may be seriously hurt by rotating parts. Make absolutely sure to read through and observe the following safety indications.

- All operations on and with the coupling have to be performed taking into account "safety first".
- Make sure to switch off the power pack before you perform your work on the coupling.
- Secure the power pack against accidental switch-on, e. g. by providing warning signs at the place of switch-on or removing the fuse for current supply.
- Do not reach into the operating area of the coupling as long as it is in operation.
- Secure the coupling against accidental contact. Provide for the necessary protection devices and covers.

Please observe protection note ISO 16016.	Drawn: 2021-09-13 Shg/Mai	Replacing: ---
	Verified: 2021-09-16 Shg	Replaced by:

 KTR KTR-Group	SINULASTIC® Operating/Assembly instructions Type B	KTR-N 48711 EN Sheet: 6 of 14 Edition: 1
---	---	--

2 Advice

2.4 Intended use

You may only assemble, operate and maintain the coupling if you

- have carefully read through the operating/assembly instructions and understood them
- are technically qualified and specifically trained (e. g. safety, environment, logistics)
- are authorized by your company

The coupling may only be used in accordance with the technical data (see chapter 1). Unauthorized modifications on the coupling design are not admissible. We will not assume liability for any damage that may arise. In the interest of further development we reserve the right for technical modifications.

The **SINULASTIC®** described in here corresponds to the state of the art at the time of printing of these operating/assembly instructions.

2.5 Coupling selection



For a permanent and failure-free operation of the coupling it must be selected according to the selection instructions (according to DIN 740 part 2) for the particular application (see catalogue drive technology "SINULASTIC®").

If the operating conditions (performance, speed, modifications on engine and machine) change, the coupling selection must be reviewed.

Make sure that the technical data regarding torque refer to the elastomer part only. The transmittable torque of the shaft-hub-connection must be reviewed by the customer and is subject to his responsibility.

For drives subject to torsional vibrations (drives with cyclic stress due to torsional vibrations) it is necessary to perform a torsional vibration calculation to ensure a reliable selection. Typical drives subject to torsional vibrations are e. g. drives with diesel engines, piston pumps, piston compressors etc. If requested, KTR will perform the coupling selection and the torsional vibration calculation.

2.6 Reference to EC Machinery Directive 2006/42/EC

The couplings supplied by KTR should be considered as components, not machines or partly completed machines according to EC Machinery Directive 2006/42/EC. Consequently KTR does not have to issue a declaration of incorporation. For details about safe assembly, start-up and safe operation refer to the present operating/assembly instructions considering the warnings.

Please observe protection note ISO 16016.	Drawn: 2021-09-13 Shg/Mai	Replacing: ---
	Verified: 2021-09-16 Shg	Replaced by:

 KTR-Group	SINULASTIC® Operating/Assembly instructions Type B	KTR-N 48711 EN Sheet: 7 of 14 Edition: 1
---	---	--

3 Storage, transport and packaging

3.1 Storage

The coupling hubs are supplied in preserved condition and can be stored in a dry and roofed place for 6 – 9 months.

With favourable storage conditions the properties of the elastomer part remain unchanged for up to 5 years.



The storage rooms must not include any ozone-generating devices like e. g. fluorescent light sources, mercury-vapour lamps or electrical high-voltage appliances.

Humid storage rooms are not suitable.

Make sure that condensation is not generated. The best relative air humidity is less than 65 %.



Please bear in mind that the elastomer part may be stored horizontally only.

3.2 Transport and packaging



In order to avoid any injuries and any kind of damage always make use of proper transport and lifting equipment.

The couplings are packed differently each depending on size, number and kind of transport. Unless otherwise contractually agreed, packaging will follow the in-house packaging specifications of KTR.

Please observe protection note ISO 16016.	Drawn: 2021-09-13 Shg/Mai	Replacing: ---
	Verified: 2021-09-16 Shg	Replaced by:



4 Assembly

The coupling is supplied in the following subassemblies and single parts. Before assembly the coupling has to be inspected for completeness.

4.1 Components of the couplings

Components of type B

Component	Quantity	Description
1	1	Elastomer part
2	1	Hub

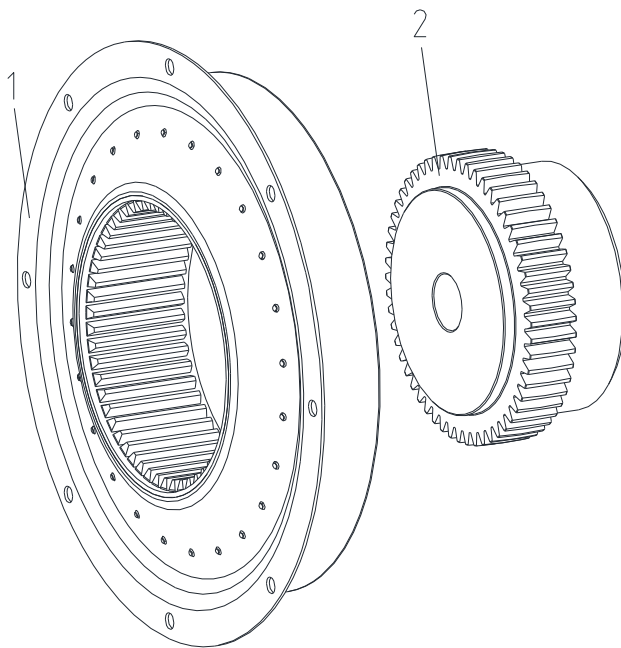

Illustration 2: SINULASTIC® type B

4.2 Advice for finish bore



The maximum permissible bore diameters D (see chapter 1 - technical data) must not be exceeded. If these figures are disregarded, the coupling may tear. Rotating particles may cause danger to life.

- Hub bores (steel hubs) machined by the customer have to observe concentricity or axial runout, respectively (see illustration 3).
- Make absolutely sure to observe the figures for $\varnothing D_{max}$.
- Carefully align the hubs when the finish bores are drilled.
- Provide for a setscrew according to DIN EN ISO 4029 with a cup point or an end plate to fasten the hubs axially.

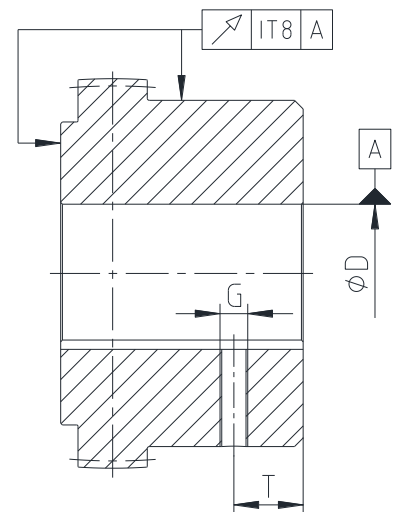

Illustration 3: Concentricity and axial runout

Please observe protection note ISO 16016.	Drawn: 2021-09-13 Shg/Mai	Replacing: ---
	Verified: 2021-09-16 Shg	Replaced by:

4 Assembly

4.2 Advice for finish bore



The customer bears the sole responsibility for all machining processes performed subsequently on unbored or pilot bored as well as finish machined coupling components and spare parts. KTR does not assume any warranty claims resulting from insufficient remachining.

Table 5: Setscrew DIN EN ISO 4029

Size	20	38	53	140	180
Dimension G	M10	M16	M16	-	-
Dimension T	20	40	40	-	-
Tightening torque T_A [Nm]	17	80	80	-	-

4.3 General advice for assembly



The SINULASTIC® coupling may only be assembled in the order described below.



In case if a dimensional drawing was prepared for the coupling, the dimensions specified have to be primarily observed.



We recommend to inspect bores, shaft, keyway and feather key for dimensional accuracy before assembly.



Heating the hubs lightly (approx. 80 °C) allows for an easier mounting on the shaft.



Touching the heated hubs causes burns. Please wear safety gloves.



We recommend to secure all screw connections against working loose additionally, e. g. applying Loctite screw adhesive (average strength), while the elastomer parts must not come into contact with any type of adhesive.

4.4 Assembly of the coupling

- Mount the hub on the shaft of the driven machine.
- Fasten the hub by tightening the setscrew DIN EN ISO 4029 with a cup point (tightening torque T_A see table 5) or an end plate.
- Mount the elastomer part in the flywheel centering.
- Align the through holes of the elastomer part to the threads of the flywheel.
- Hand-tighten the components via suitable screws (not part of the scope of delivery) first.
- Tighten the screws at the tightening torques T_A specified in table 6 by means of a suitable torque wrench.
- Secure the screwing by means of a suitable screw glue.

Please observe protection note ISO 16016.	Drawn: 2021-09-13 Shg/Mai	Replacing: ---
	Verified: 2021-09-16 Shg	Replaced by:



4 Assembly

4.4 Assembly of the coupling



Observe the manufacturer's instructions regarding the use of adhesives. Do not apply adhesives on the rubber surfaces.

Table 6: Screw tightening torques for screwing the elastomer part to the engine flywheel

Size of flywheel acc. to SAE - J620 ¹⁾	11 1/2"	14"	18"	21"	24"	Ø475 ²⁾
Screw size	M10	M12	M16			M10
Tightening torque [Nm]	49	120	295			49
Minimum screw strength	8.8	10.9				8.8
Inch screw	3/8 - 16	1/2 - 13		5/8 - 11		3/8 - 16
Tightening torque [Nm]	42	150		286		42
Minimum screw strength	5	8				5

1) For dimensions of flange connection see table 3.

2) Flange connection differing from SAE standard, dimensions in mm see table 3.

- Shift the machine components in axial direction until the distance dimension L4 is achieved.



With the assembly make sure that the spline of the hub is fully covered by the internal spline of the elastomer. (Observe mounting dimensions L4). Disregarding this advice may cause damage to the coupling.

- If the position of the machine components is already fixed, the mounting dimension can be set by shifting the hub axially on the shaft.

4.5 Displacements - alignment of the couplings

The **SINULASTIC®** flange couplings compensate for changes in position of the machine components to be connected up to the data specified in table 7.

With alignment, the radial and angular displacement should be kept as small as possible, because the service life is increased in this way if the operating conditions are otherwise maintained.

The **SINULASTIC®** flange coupling has to be aligned from the coupling hub on the shaft side to one of the machined surfaces of the flywheel or machine.



In order to ensure a long service life of the coupling, the shaft ends have to be accurately aligned. Please absolutely observe the displacement figures specified (see table 7). If the figures are exceeded, the coupling will be damaged. The more accurate the alignment of the coupling, the longer is its service life.

Please note:

- The displacement figures specified in table 7 are maximum figures which must not arise in parallel. If radial and angular displacements arise at the same time, the permissible displacement values may only be used proportionally (see illustration 5).
- The displacement figures specified are general standard figures that apply up to an ambient temperature of 80 °C, ensuring a sufficient service life of the **SINULASTIC®** coupling. Displacement figures between the speeds specified have to be interpolated accordingly. If necessary, ask about the displacement for the corresponding coupling type.
- Inspect with a dial gauge, ruler or feeler gauge whether the permissible displacement figures specified in table 7 can be observed.

Please observe protection note ISO 16016.	Drawn: 2021-09-13 Shg/Mai	Replacing: ---
	Verified: 2021-09-16 Shg	Replaced by:

4 Assembly

4.5 Displacements - alignment of the couplings

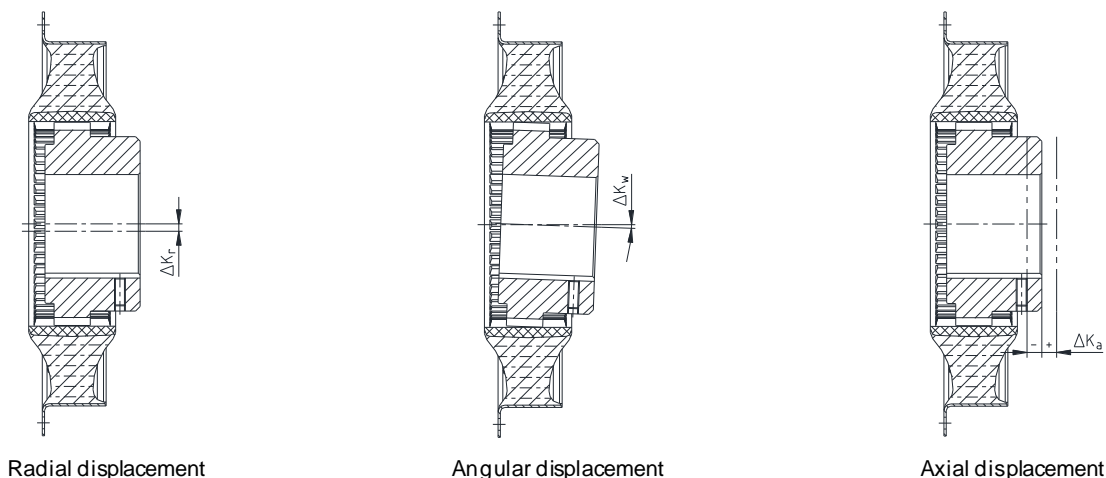

Illustration 4: Displacements

Examples of the displacement combinations specified in illustration 5:

Example 1:
 $\Delta K_r = 30 \%$
 $\Delta K_w = 70 \%$

Example 2:
 $\Delta K_r = 60 \%$
 $\Delta K_w = 40 \%$

Illustration 5: Combinations of displacement

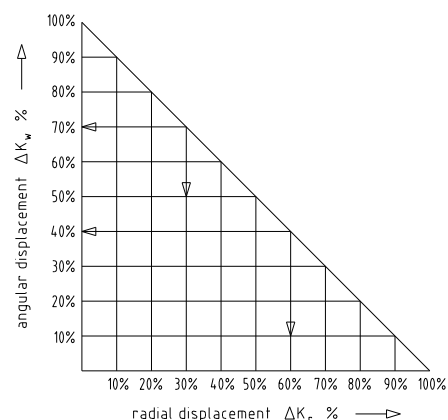

$$\Delta K_{\text{total}} = \Delta K_r + \Delta K_w \leq 100 \%$$

Table 7: Displacement figures

Displacement figures		Size				
		20	38	53	140	180
Perm. radial displacement ΔK_r [mm] with n =	1500 rpm	0.8	1.1	1.1	1.5	1.5
	Max.	0.6	0.8	0.8	1.1	1.1
Max. radial displacement ΔK_r [mm] ¹⁾		1.6	2.2	2.2	3.0	3.0
Perm. angular displacement ΔK_w [degree] with n =	1500 rpm	1.0	0.8	0.8	0.6	0.6
	Max.	0.7	0.6	0.6	0.4	0.4
Max. angular displacement ΔK_w [degree] ¹⁾		2	1.6	1.6	1.2	1.2
Perm. axial displacement ΔK_a [mm] ²⁾		±2	±3	±3	±4	±4

- 1) For short-term start-up operation
- 2) Plug-in spline connection must fully bear

	SINULASTIC® Operating/Assembly instructions Type B	KTR-N 48711 EN Sheet: 12 of 14 Edition: 1
--	---	---

5 Start-up

Before start-up of the coupling, inspect the alignment and the distance dimension L4 and adjust, if necessary, and also inspect all screw connections for the tightening torques specified.

Finally the coupling protection against accidental contact must be fitted. It is required in accordance with DIN EN ISO 12100 (Safety of Machinery) and directive 2014/34/EU and must protect against

- access with a little finger
- falling down of solid foreign objects.

The cover may provide for openings intended for necessary heat dissipation. These openings have to comply with DIN EN ISO 13857.

During operation of the coupling, please pay attention to

- different operating noise
- vibrations occurring.



If you note any irregularities with the coupling during operation, the drive unit must be switched off immediately. The cause of the breakdown must be specified by means of the table „Breakdowns“ and, if possible, be eliminated according to the proposals. The potential breakdowns specified can be hints only. To find out the cause all operating factors and machine components must be considered.

6 Breakdowns, causes and elimination

The below-mentioned failures can lead to improper use of the **SINULASTIC®** coupling. In addition to the specifications given in these operating/assembly instructions make sure to avoid such failures.

The errors listed can only be clues to search for the failures. When searching for the failure the adjacent components must generally be considered.

General failures with use other than intended:

- Important data for the coupling selection are not forwarded.
- The calculation of the shaft-hub-connection is not considered.
- Coupling components with damage occurred during transport are assembled.
- If the heated hub is assembled, the permissible temperature is exceeded.
- The clearance of the components to be assembled is not coordinated with one another.
- Tightening torques have been fallen below/exceeded.
- Components are mixed up by mistake/assembled incorrectly.
- No original **KTR** components (purchased parts) are used.
- Old/already worn out elastomer parts or those stored for too long are used.
- Maintenance intervals are not observed.

Please observe protection note ISO 16016.	Drawn: 2021-09-13 Shg/Mai	Replacing: ---
	Verified: 2021-09-16 Shg	Replaced by:



6 Breakdowns, causes and elimination

Breakdowns	Causes	Elimination
Different operating noise and/or vibrations occurring	Micro friction by faulty alignment on the spline of the elastomer part	1) Set the unit out of operation 2) Eliminate the reason for the misalignment (e. g. loose foundation bolts, fracture of the engine mount, heat expansion of unit components, modification of the installation dimension E of the coupling) 3) For visual inspection/inspection of wear see chapter 8 <i>Maintenance</i>
	Axial fastening of hub working loose	1) Set the unit out of operation 2) Inspect alignment of coupling 3) For visual inspection/inspection of wear see chapter 8 <i>Maintenance</i> 4) Secure the hubs axially and against working loose
Fracture of elastomer part	Fracture of elastomer part/high dynamic energy/overload	1) Set the unit out of operation 2) Disassemble the coupling and remove remainders of the elastomer part 3) Inspect coupling components and replace coupling components that are damaged 4) Insert elastomer part, assemble coupling components 5) Find out the reason for overload
	Operating parameters do not meet with the performance of the coupling	1) Set the unit out of operation 2) Review the operating parameters and select a bigger coupling (consider mounting space) 3) Assemble new coupling size 4) Inspect alignment
	Operating error of the unit	1) Set the unit out of operation 2) Disassemble the coupling and remove remainders of the elastomer part 3) Inspect coupling components and replace coupling components that are damaged 4) Insert elastomer part, assemble coupling components 5) Instruct and train the service staff
Excessive wear on the spline of the elastomer part, fracture of elastomer	Vibrations of drive	1) Set the unit out of operation 2) Disassemble the coupling and remove remainders of the elastomer part 3) Inspect coupling components and replace coupling components that are damaged 4) Insert elastomer part, assemble coupling components 5) Inspect alignment, adjust if necessary 6) Find out the reason for vibrations
	Ambient/contact temperatures which are too high for the elastomer part, max. permissible -30 °C/+80 °C	1) Set the unit out of operation 2) Disassemble the coupling and remove remainders of the elastomer part 3) Inspect coupling components and replace coupling components that are damaged 4) Insert elastomer part, assemble coupling components 5) Inspect alignment, adjust if necessary 6) Inspect and adjust ambient/contact temperature
	e. g. contact with aggressive liquids/oils, influence by ozone, too high ambient temperature etc. causing a physical change of the elastomer part	1) Set the unit out of operation 2) Disassemble the coupling and remove remainders of the elastomer part 3) Inspect coupling components and replace coupling components that are damaged 4) Insert elastomer part, assemble coupling components 5) Inspect alignment, adjust if necessary 6) Make sure that other physical modifications of the elastomer part are excluded

7 Disposal

In respect of environmental protection we would ask you to dispose of the packaging resp. products on termination of their service life in accordance with the legal regulations and standards that apply.

- **Metal**
Any metal components have to be cleaned and disposed of by scrap metal.
- **Nylon materials**
Nylon materials have to be collected and disposed of by a waste disposal company.

Please observe protection note ISO 16016.	Drawn: 2021-09-13 Shg/Mai	Replacing: ---
	Verified: 2021-09-16 Shg	Replaced by:



8 Maintenance and service

We recommend to perform a visual inspection on the coupling **at least once a year**. Please pay special attention to the condition of the elastomer part of the coupling.

- Remove loose dirt from the coupling.
- Inspect the coupling for spalling or missing components, if necessary. Inspect the elastomer part in particular for cracks.
- Defective components must be replaced immediately resp. missing components must be replaced immediately.
- Inspect and correct the tightening torques of all screw connections, if necessary.
- Since the flexible machine bearings of the driving and driven side settle during the course of load, inspect the alignment of the coupling and re-align the coupling, if necessary.

Please perform visual inspection as follows:

- Inspect adhesion ① of elastomer part to the inner and outer component (metal and plastic).
- Inspect the elastomer part for cracks in the areas marked with ④ in illustration 6.
If the depth of cracks achieve the limit of 3.0 mm or exceed it in the area marked with ④, the elastomer part must be replaced.



Elastomer parts that are damaged or worn off have to be replaced, with the maintenance interval of the engine at the latest.

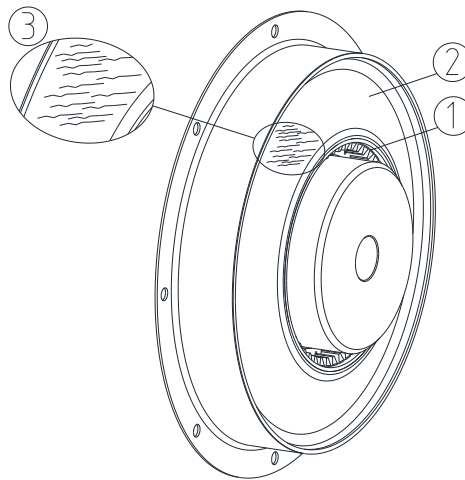

Illustration 6: Visual inspection

9 Spares inventory, customer service addresses

We recommend to store major spare parts on site to ensure the readiness for use of the machine in case if a coupling fails.

Contact addresses of the KTR partners for spare parts and orders can be obtained from the KTR homepage at www.ktr.com.



KTR does not assume any liability or warranty for the use of spare parts and accessories which are not provided by KTR and for the damages which may incur as a result.

Please observe protection note ISO 16016.	Drawn: 2021-09-13 Shg/Mai	Replacing: ---
	Verified: 2021-09-16 Shg	Replaced by: