

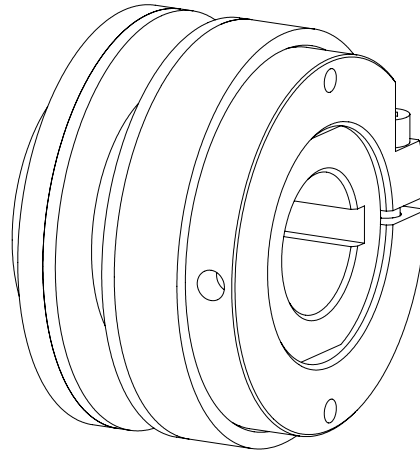

RUFLEX® with clampable setting nut



The **RUFLEX®-torque limiter** is an overload system which operates as frictionally engaged connection. It protects the following components in the drive lane against destruction.

Table of Contents

1 Technical Data

2 Hints

- 2.1 General Hints
- 2.2 Safety and Advice Hints
- 2.3 General Hints to Danger
- 2.4 Proper Use
- 2.5 Hint Regarding the Finish Bore

3 Storage

4 Assembly

- 4.1 Components RUFLEX®-Torque Limiter
- 4.2 Assembly (General)
- 4.3 Centering Slide Bush
- 4.4 Disc Spring Layer
- 4.5 Initial Adjustment or New Adjustment of the Slipping Torque
- 4.6 Modification of Slipping Torque
- 4.7 Diagrams of Adjustment
- 4.8 Spares Inventory, Customer Service Addresses



1 Technical Data

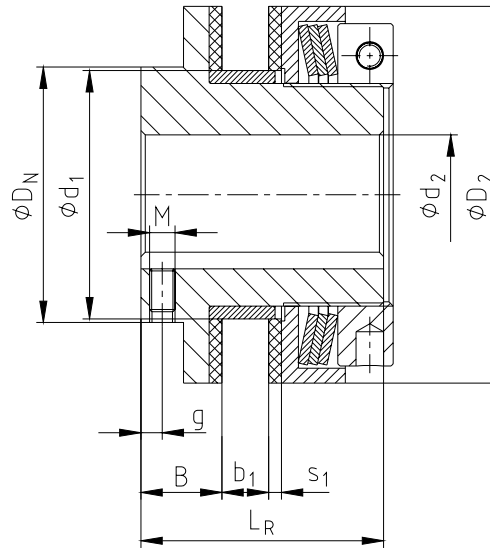

picture 1: dimensions

Table 1:

Size	Max. speed [1/min]	Dimensions [mm]										
		d ₂ max.	D _N	D ₂	d ₁ ²⁾	B	b ₁		s ₁	L _R	Threads for setcrews	
							min.	max.			M	g
0	8500	20 ¹⁾	45	45	35	8,5	2	6	2,5	33	M4	3
01	6600	22	40	58	40	16	3	8	3	45	M5	4
1	5600	25	45	68	44	17	3	10	3	52	M5	5
2	4300	35	58	88	58	19	4	12	3	57	M6	5
3	3300	45	75	115	72	21	5	15	4	68	M6	5
4	2700	55	90	140	85	23	6	18	4	78	M8	5
5	2200	65	102	170	98	29	8	20	5	92	M8	8

1) Finish bore larger than Ø19, keyway to DIN 6885 sheet 3

2) bore tolerance (drive component): F8 at size 0 - 4
H8 at size 5

2 Hints

2.1 General Hints

Please read through these mounting instructions carefully before you set the torque limiter into operation. Please pay special attention to the safety instructions!

The mounting instructions are part of your product. Please keep them carefully and close to the torque limiter. The copyright for these mounting instructions remains with **KTR Kupplungstechnik GmbH**.

2.2 Safety and Advice Hints



DANGER!

Danger of injury to persons.



CAUTION!

Damages on the machine possible.



ATTENTION!

Pointing to important items.

Schutzvermerk ISO 16016 beachten.	Gezeichnet: 24.06.10 Li/Lm	Ersatz für: KTR-N vom 30.03.07
	Geprüft: 24.06.10 Li	Ersetzt durch:



2 Hints

2.3 General Hints to Danger



DANGER!

With assembly, operation and maintenance of the torque limiter it has to be made sure that the entire drive train is secured against unintentional engagement. You can be seriously hurt by rotating parts. Please make absolutely sure to read through and observe the following safety instructions.

- All operations on and with the torque limiter have to be performed taking into account "safety first".
- Please make sure to disengage the drive unit and the power packs in service before you perform your work.
- Secure the drive unit against unintentional engagement, e. g. by providing hints at the place of engagement or removing the fuse for current supply.
- Do not touch the operation area of the torque limiter as long as it is in operation.
- Please secure the torque limiter against unintentional touch. Please arrange for the corresponding protection devices and caps.

2.4 Proper Use

You may only assemble, operate and maintain the torque limiter if you

- have carefully read through the mounting instructions and understood them
- had technical training
- are authorized to do so by your company

The torque limiter may only be used in accordance with the technical data (see **RUFLEX®**-catalogue). Unauthorized modifications on the torque limiter design are not admissible. We do not take any warranty for resulting damages. To further develop the product we reserve the right for technical modifications. The **RUFLEX®** described in here corresponds to the technical status at the time of printing of these mounting instructions.

2.5 Hint regarding the Finish Bore



DANGER!

The maximum permissible bore diameters d_2 (see table 1 in chapter 1 - Technical Data) must not be exceeded. If these figures are disregarded, the coupling may tear. Rotating particles may cause serious danger.

- Hub bores machined by the customer have to observe concentric running or axial running, respectively (see picture 2).
- Please make absolutely sure to observe the figures for d_{max} .
- Carefully align the hubs when the finish bores are brought in.
- Please provide for a setscrew or an end plate for the axial fastening of the hubs.

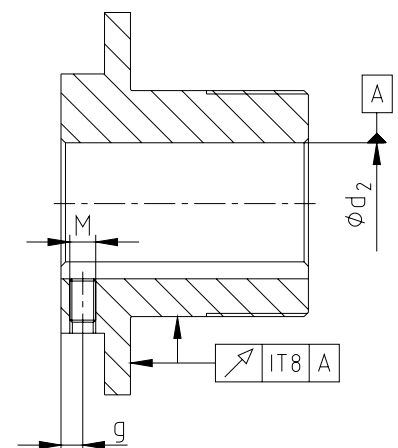

picture 2: concentric running and axial running



CAUTION!

The orderer is responsible for all subsequently made machinings to unbored or pilot bored and to finish machined coupling parts and spare parts. KTR does not assume any warranty claims resulting from insufficient refinish.

Schutzvermerk ISO 16016 beachten.	Gezeichnet: 24.06.10 Li/Lm	Ersatz für: KTR-N vom 30.03.07
	Geprüft: 24.06.10 Li	Ersetzt durch:



3 Storage

The couplings are supplied in preserved condition and can be stored at a dry and roofed place for 6 - 9 months.



CAUTION!

Humid storage rooms are not suitable.

Please make sure that there is no condensation. The best relative air humidity is under 65%.

4 Assembly

The RUFLEX®-torque limiter is delivered in assembled condition.

4.1 Components RUFLEX®-Torque Limiter

Component	Quantity	Designation	Component	Quantity	Designation
1	1	Hub	6	2	Friction lining
2	1	Pressure ring	7	1	Slide bush
3	1	Clampable setting nut	8	1	Setscrew DIN EN ISO 4029
4	1	Clamping screw	9	1	Drive component (e. g. sprocket)
5	s. table 3	Disc spring			

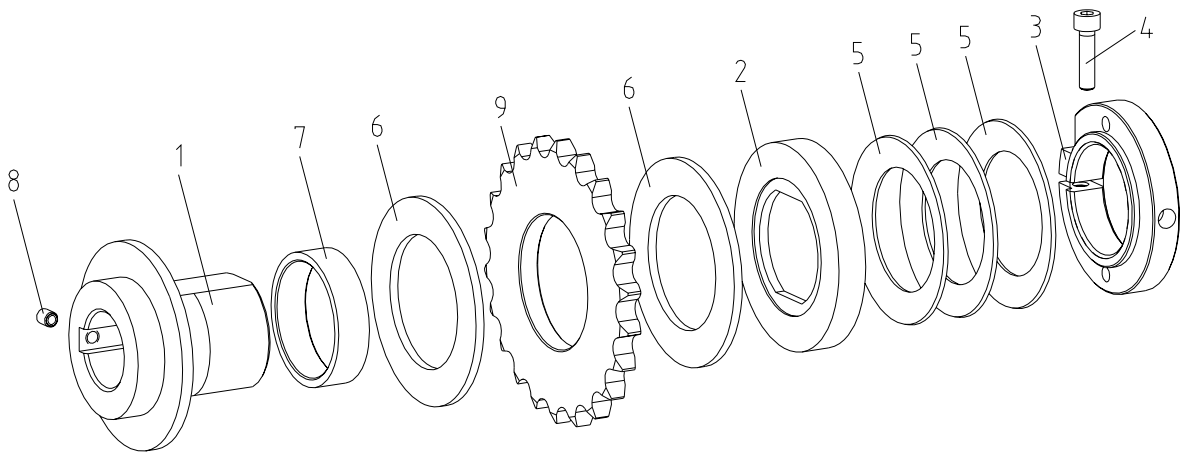

picture 3: RUFLEX® size 0 - 5

4.2 Assembly (General)



ATTENTION!

We recommend to check bores, shaft, keyway and feather key for dimensional accuracy before assembly.

- Please make sure that the RUFLEX® torque limiter is in a technically excellent condition.
- Clean the sliding surfaces of the hub, the drive component, the pressure disc and the friction linings concerning dirt, oil and grease.
- Protect the torque limiter against any axial displacement on the shaft by a set screw DIN EN ISO 4029 with toothed cup point or end disc.



CAUTION!

Dirty sliding surfaces affect the function of the torque limiter.

Schutzvermerk ISO 16016 beachten.	Gezeichnet: 24.06.10 Li/Lm	Ersatz für: KTR-N vom 30.03.07
	Geprüft: 24.06.10 Li	Ersetzt durch:



4 Assembly

4.3 Centering Slide Bush

- Check the width of the centering slide bush.

$$\text{ZenBu} = 1,5 \times s_1 + b_1$$

Example:

RUFLEX®-torque limiter size 1
Width of drive component e. g. $b_1 = 8 \text{ mm}$
Width of friction lining $s_1 = 3 \text{ mm}$

$$\text{ZenBu} = 1,5 \times 3 + 8 = \underline{12,5 \text{ mm}}$$

ZenBu = If you do not indicate the width of the drive component when placing your order, the centering slide bush is delivered in max. width.

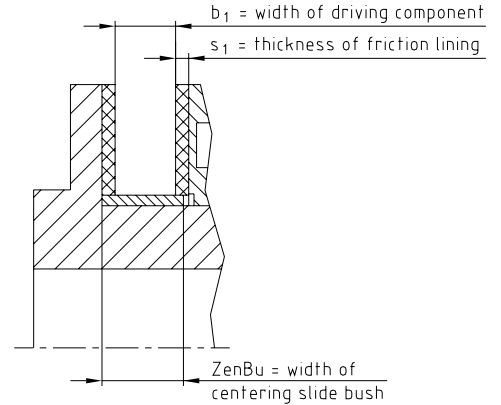

picture 4: centering slide bush



CAUTION!

If you do not observe the stipulated width of the centering slide bush, the function of the torque limiter is not guaranteed.

Table 2:

RUFLEX® size	0	01	1	2	3	4	5
Max. width of the centering slide bush	10	13	15	17	21,5	24,5	28

4.4 Disc Spring Layer

single layer (standard)

1TF
size 0 - 5



double layer

2TF
size 0 - 5



triple layer

3TF
size 1 - 5

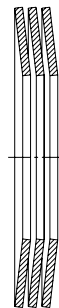

picture 5: disc spring layer

Table 3:

RUFLEX® size	0	01	1	2	3	4	5
Number of disc springs							
1TF	1	1	1	1	1	1	1
2TF	2	2	2	2	2	2	2
3TF	-	-	3	3	3	3	3



4 Assembly

4.5 Initial Adjustment or New Adjustment of the Slipping Torque

1. Secure the hub against torsion.
2. Detach the clamping screw in the setting nut.
3. Tighten the setting nut manually and clockwise until the limit stop.
4. Please turn the setting nut clockwise with the hook wrench until reaching the requested setting angle (slipping torque). Please look at the diagrams of adjustment 1 to 7.
5. After having adjusted the requested slipping torque, fix the setting nut onto the thread part of the hub by screwing the clamping screw.

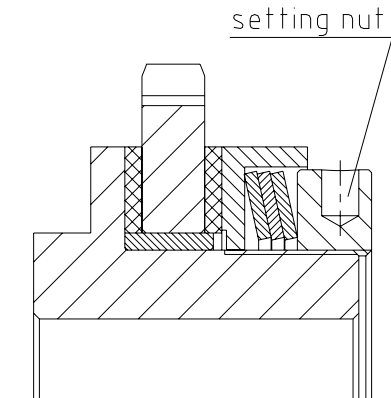

picture 6: torque adjustment



CAUTION!
The RUFLEX®-torque limiter must not exceed the max. slipping torque!



CAUTION!
The slipping torques indicated in the diagrams refers to the drive parts of steel or cast iron! During the running-in phase (adaption of the friction partners), after a long standstill and during or after long slipping procedures, there can be a change of the slipping torque.



picture 7: hinged hook wrench

RUFLEX® size	Hinged hook wrench with tappet
0	Ø35 - 60 x 4
01	Ø35 - 60 x 4
1	Ø60 - 90 x 6
2	Ø60 - 90 x 6
3	Ø90 - 155 x 8
4	Ø90 - 155 x 8
5	Ø155 - 230 x 8

4.6 Modification of Slipping Torque

- Secure the hub against torsion.
- Detach the clamping screw in the setting nut.
- Please turn the setting nut (clockwise for higher slipping torque, anticlockwise for lower slipping torque) with the hook wrench until reaching the requested setting angle (please look at the diagrams of adjustment 1 to 7).
- After having adjusted the requested slipping torque, fix the setting nut onto the thread part of the hub by screwing the clamping screw.



CAUTION!
The RUFLEX®-torque limiter must not exceed the max. slipping torque!



4 Assembly

4.7 Diagrams of Adjustment

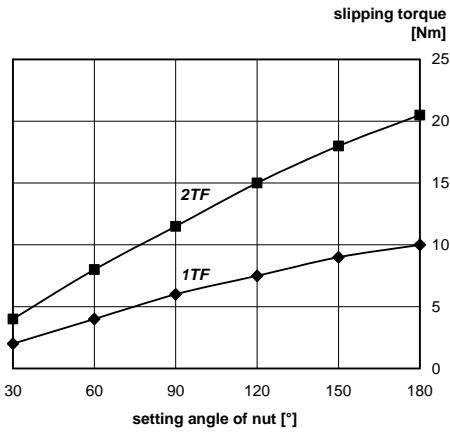

diagram 1: RUFLEX® size 0

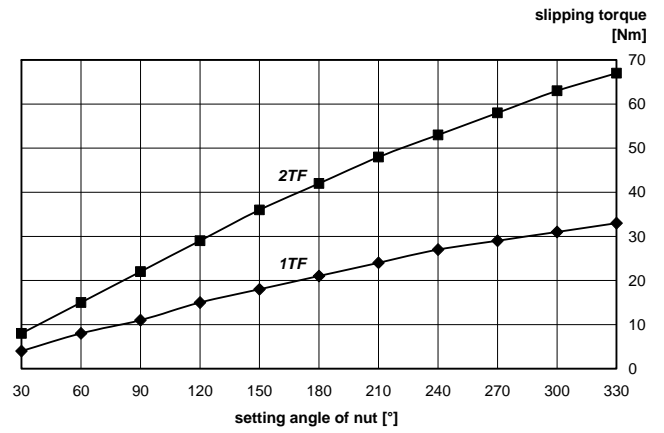

diagram 2: RUFLEX® size 01

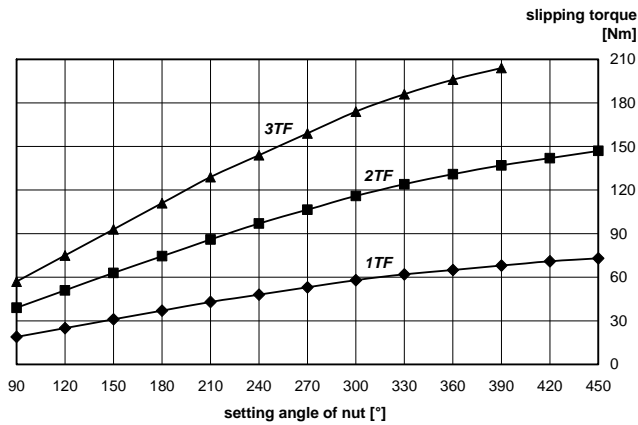

diagram 3: RUFLEX® size 1

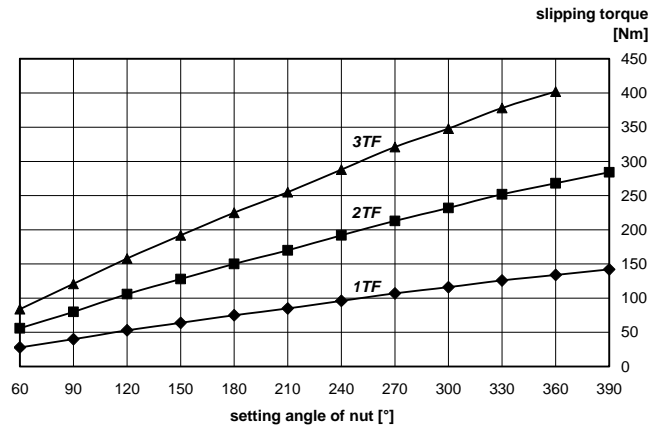

diagram 4: RUFLEX® size 2

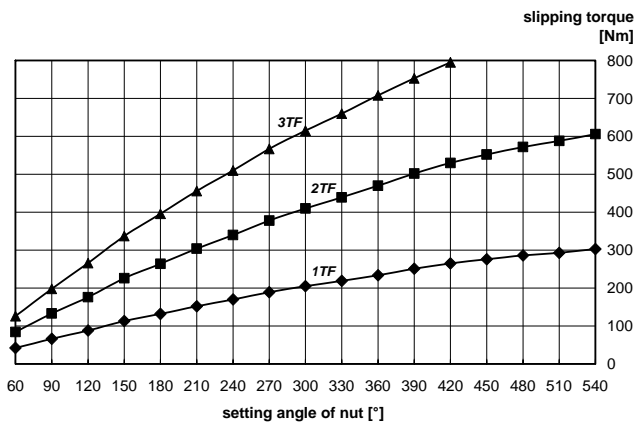

diagram 5: RUFLEX® size 3

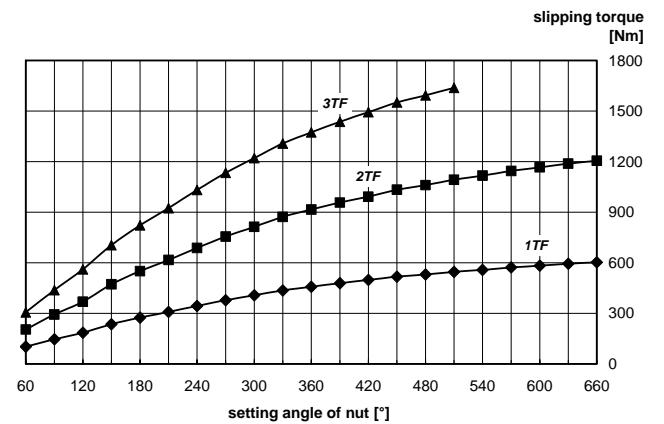

diagram 6: RUFLEX® size 4



4 Assembly

4.7 Diagrams of Adjustment

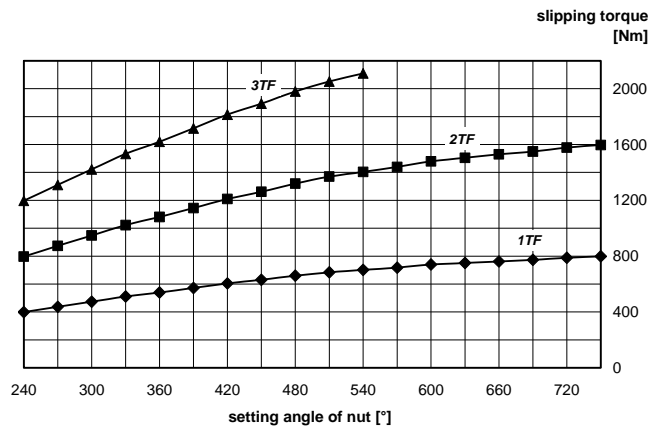

diagram 7: RUFLEX® size 5

4.8 Spares Inventory, Customer Service Addresses

A basic requirement to guarantee the operational readiness of the coupling is a stock of the most important spare parts on site.

Contact addresses of the KTR partners for spare parts and orders can be obtained from the KTR homepage under www.ktr.com.