



DATAFLEX®
Torque measuring shaft

Made for Motion



Table of contents



DATAFLEX®	
Torque measuring shaft	307
Overview	309
NEW Type 16/10, 16/30, 16/50	310
Accessories: RADEX®-NC Servo laminae coupling	310
Type 22/20, 22/50, 22/100	311
Accessories: RADEX®-NC Servo laminae coupling	311
Type 42/200, 42/500, 42/1000	312
Accessories: RADEX®-N Steel laminae coupling	312
Type 85/2000, 85/5000, 85/10000	313
Accessories: RADEX®-N Steel laminae coupling	313
Type 140/20000, 140/50000	314
NEW Connecting housing DF2 and connecting cable	314

DATAFLEX® 16 – High accuracy for low torques

The recently developed DATAFLEX® 16 extends the existing range of contactless torque measuring shafts and is available for measuring torque ranges of 10 Nm, 30 Nm and 50 Nm.

The torque is measured using the well-approved technology of wire strain gauges combined with the latest electronic components. The torque signals are processed without contact at a high resolution of 24 bit achieving an accuracy of 0,1 %. Supplementary to torque measuring the size 16 has a speed encoder providing two offset impuls with a resolution of 360 pulses per revolution.



DATAFLEX® 22, 42, 85, 140 – Patented technology

The DATAFLEX® torque measuring shafts sizes 22 to 140 measure the torques without contact and free from wear. Their secret is a patented measuring method acquiring the twisting of the torsion shaft by measuring the quantity of light. For that purpose the light is directed through two disks the transparency of which is amended proportionally to the torque. The overall electronics are situated in a stationary housing to make sure that no signals have to be transmitted by the rotating shaft and the torque is available accurately with a high band width of 16 kHz. This can measure and analyze highly dynamic processes accurately.

The analog output values are available both as a voltage signal from 0 – 10 V and as a current signal from 4 – 20 mA. In addition a speed encoder is integrated providing a signal at a resolution of 60 impuls per revolution.



Connection housing DF2 – All Inclusive

The connection housing DF2 can easily be combined with all DATAFLEX® torque measuring shafts disposing of a retainer for top hat rail assembly as well as terminal screws for an easy connection of external devices.

The following features save the purchase of expensive measuring amplifiers and converters:

- The torque output can be filtered over 5 steps so that short torque peaks in the display can be reduced.
- The pulse signal of the speed output can be configured both for 5V (TTL) and 24V (HTL). This makes the speed signal compatible for data logging boards and SPS controls.
- In parallel with the pulse signal an integrated frequency voltage converter supplies a DC voltage from 0 – 10 V proportionally to the speed, the scaling of which can be changed individually. This makes an expensive counter superfluous so that the signal can either be processed as a voltage or can be displayed.
- A direction signal indicates the rotational direction of the drive (with DATAFLEX® 16).



Couplings adjusted to every application

With all DATAFLEX® sizes we recommend the servo lamina coupling RADEX®-NC and the steel lamina coupling RADEX®-N, a compact solution which can be quickly integrated having a high stiffness. In general it is also possible to use backlash-free plug-in couplings such as ROTEX® GS or to integrate an overload coupling.



Type 16/10, 16/30, 16/50



- Precision measuring shaft for low torques
- Inaccuracy < 0,1 % of the measuring range
- Double channel speed measurement at 360 pulses/revolution
- Reliable values measured in the machine control, process control, test stand dynamometers
- Space-saving combination with servo lamina coupling RADEX®-NC
- Compensating for angular, radial and axial displacements

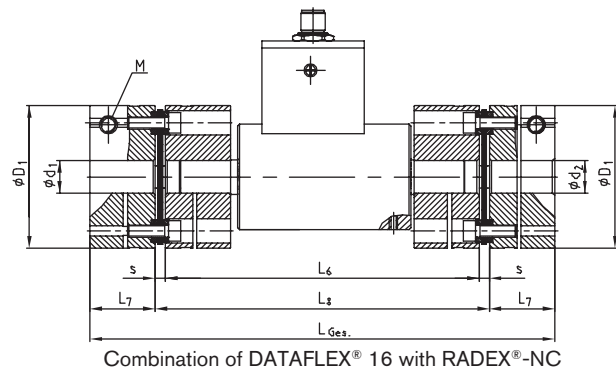
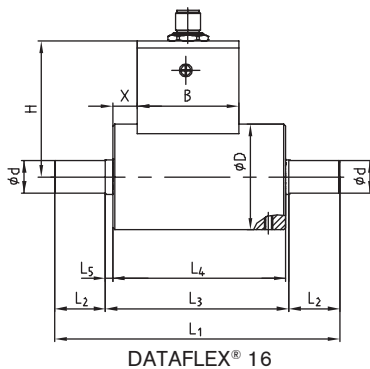

General features										
DATAFLEX® Type	Rated torque T_{KN} [Nm]		Distribution voltage [V]		Current consumption [mA]		Nominal temperature range [°C]			
16/10	-10 ... +10		24 ± 4		< 100		0 ... 55			
16/30	-30 ... +30									
16/50	-50 ... +50									
Technical data torque signal					Technical data speed signal					
DATAFLEX® Type	Inaccuracy ^{1,2)} [%]	Output voltage [V]	Band width [kHz]	Influence of temperature ¹⁾ [%/10 °C]	Resolution (pulses/rev.)	Number of channels	Square wave signal ³⁾ [Vss]	Direct-voltage signal ³⁾ (V)	Direction signal ³⁾ [V]	
16/10										
16/30	<0,1	-10 ... 10	2	0,05	360	2, 90° offset	5/24	0 ... 10 to be scaled	5/24	
16/50										
Mechanical data of torque measuring shaft										
DATAFLEX® Type	Static load limit T_K max [%] ¹⁾	Breaking load T_K Break [%] ¹⁾	Max. bending moment [Nm]	Max. radial force [N]	Max. axial force [kN]	Weight [kg]	Torsion spring stiffness C_T [Nm/rad]	Twisting angle with T_{KN} [°]	Mass moment of inertia [kgmm ²]	Max. speed [rpm]
16/10			1,07	12	1,1		910	0,63		
16/30	150	300	3,2	37	2,3	0,69	2840	0,61	22,6	10000
16/50			5,3	61	3,1		4100	0,7		

Dimensions (mm) of torque measuring shaft and coupling combination																		
DATAFLEX® Type	d	D	L ₁	L ₂	L ₃	L ₄	L ₅	H	B	X	RADEX®-NC Size	D ₁	d ₁ /d ₂ max	s	L ₆	L ₇	L ₈	L _{Ges.}
16/10											20	59	25	4	138	24	146	194
16/30	16	52	140	25	90	85	3,5	67	50	12	25	70	35	5	154	32	164	228
16/50																		

¹⁾ Referring to T_{KN} ²⁾ Errors in linearity incl. hysteresis ³⁾ See page 314: connection housing DF2

Type 16/10, 16/30, 16/50 – Accessories: RADEX®-NC Servo laminae coupling

Mechanical data of the combination DATAFLEX® 16 and RADEX®-NC							
DATAFLEX® Type	RADEX®-NC Size	Coupling		Mechanical data of the entire system			
		Clamping screw M		Mass moment of inertia [kgmm ²]	Torsion spring stiffness C_T [Nm/rad]	Weight [kg]	Max. speed [rpm] ⁴⁾
M	T_A [Nm]						
16/10	20	M6	10	177	860	1,30	
16/30					2600	1,75	6000
16/50	25	M8	25	416	3600	1,75	

⁴⁾ Higher speed on request

Order form	DATAFLEX® 16/30	DF2	2 m	RADEX®-NC 25 EK Ø16/20-Ø16/30
Type of measuring shaft with measuring range	Connection housing (cannot be freely selected)		Length of connection cable in metres	In case that accessories are requested: coupling type, finish bores d/d_1 - d/d_2

Type 22/20, 22/50, 22/100



- DATAFLEX® 22 for low torques
- Contactless measurement
- Integrated speed signal
- Very wide signal band width
- Reliable values measured in the machine control, process control and test stand dynamometers
- Space-saving combination with servo lamina coupling RADEX®-NC
- Compensating for angular, radial and axial displacements

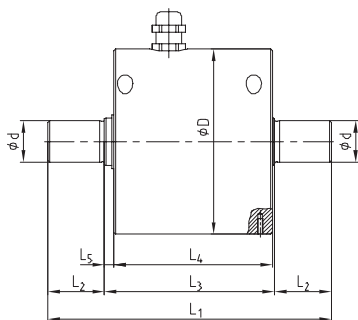

DATAFLEX® 22

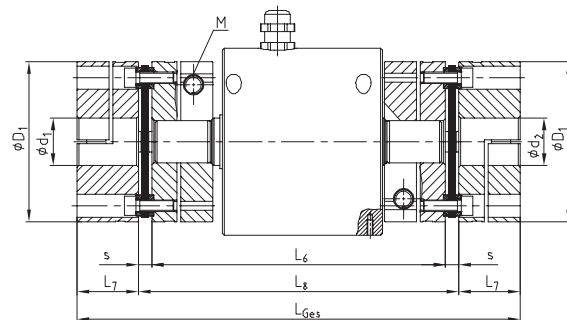

Combination of DATAFLEX® 22 with RADEX®-NC

General features										
DATAFLEX® Type	Rated torque T_{KN} [Nm]		Distribution voltage [V]		Current consumption [mA]		Nominal temperature range [°C]			
22/20	-20 ... +20		24 ± 4		< 100		0 ... 55			
22/50	-50 ... +50									
22/100	-100 ... +100									
Technical data torque signal						Technical data speed signal				
DATAFLEX® Type	Inaccuracy ¹⁾ [%]	Output voltage [V]	Output of current [mA]	Band width [kHz]	Influence of temperature ¹⁾ [%/10 °C]	Resolution (pulses/rev.)	Number of channels	Square wave signal ²⁾ [V _{SS}]	Direct-voltage signal ²⁾ [V]	Direction signal ²⁾ [V]
22/20										
22/50	< ±0,5	0 ... 10	4 ... 20	16	0,5	60	1	5/24	0 ... 10, to be scaled	-
22/100										
Mechanical data of torque measuring shaft										
DATAFLEX® Type	Static load limit $T_{K \max}$ [%] ¹⁾	Breaking load $T_{K \text{ Break}}$ [%] ¹⁾	Max. bending moment [Nm]	Max. radial force [N]	Max. axial force [kN]	Weight [kg]	Torsion spring stiffness C_T [Nm/rad]	Twist angle with T_{KN} [°]	Mass moment of inertia [kgm ²]	Max. speed [rpm]
22/20			5	42	3		2865		0,000131	
22/50	150	300	10	84	5	1,5	7163	0,4	0,000132	8000
22/100			18	150	7,5		14325		0,000134	

Dimensions (mm) of torque measuring shaft and coupling combination															
DATAFLEX® Type	d	D	L ₁	L ₂	L ₃	L ₄	L ₅	RADEX®-NC Size	D ₁	d ₁ /d ₂ max	s	L ₆	L ₇	L ₈	L _{Ges.}
22/20								25	70	35	5	154	32	164	228
22/50	22	98	150	30	90	84	5	35	84	40	7	160	35	174	244
22/100															

¹⁾ Referring to T_{KN}

²⁾ See page 314: connection housing DF2

Type 22/20, 22/50, 22/100 – Accessories: RADEX®-NC Servo laminae coupling

Mechanical data of the combination DATAFLEX® 22 and RADEX®-NC							
DATAFLEX® Type	RADEX®-NC Size	Coupling		Mechanical data of the entire system			
		Clamping screw M	T_A [Nm]	Mass moment of inertia [kgm ²]	Torsion spring stiffness C_T [Nm/rad]	Weight [kg]	Max. speed [rpm] ³⁾
22/20	25	M8	25	0,00094	2521	2,56	6000
22/50	35	M10	49	0,002	6383	3,15	
22/100					11448	3,16	

³⁾ Higher speed on request

Order form	DATAFLEX® 22/50	DF2	2 m	RADEX®-NC 35 EK Ø22/30-Ø22/35
	Type of measuring shaft with measuring range	Connection housing selectable (DF1 or DF2)	Length of connection cable in metres	In case that accessories are requested: coupling type, finish bores d/d ₁ -d/d ₂

Type 42/200, 42/500, 42/1000

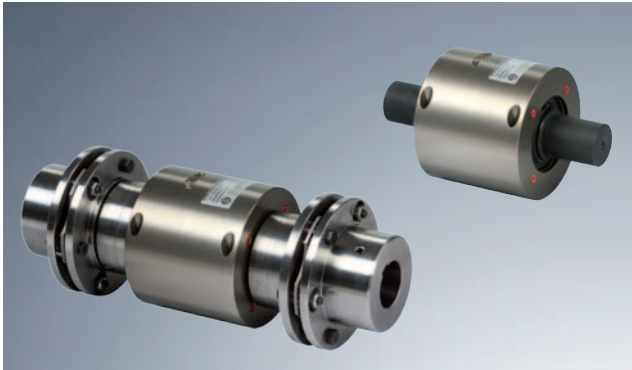

- DATAFLEX® 42 for middle torques
- Contactless measurement
- Integrated speed signal
- Very wide signal band width
- Reliable values measured in the machine control, process control and test stand dynamometers
- Space-saving combination with servo lamina coupling RADEX®-N
- Compensating for angular, radial and axial displacements

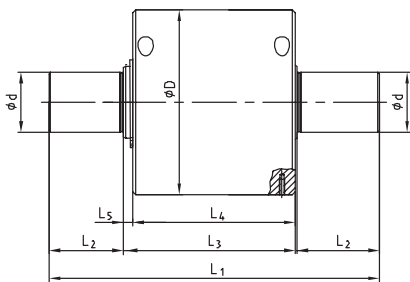

DATAFLEX® 42

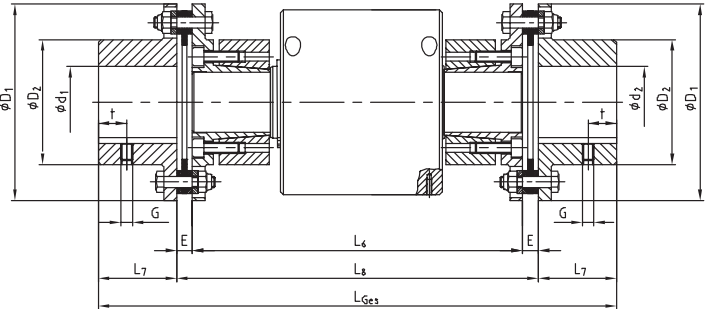

Combination of DATAFLEX® 42 with RADEX®-N

General features										
DATAFLEX® Type	Rated torque T_{KN} [Nm]		Distribution voltage [V]		Current consumption [mA]		Nominal temperature range [°C]			
42/200	-200 ... +200		24 ± 4		< 100		0 ... 55			
42/500	-500 ... +500									
42/1000	-1000 ... +1000									
Technical data torque signal					Technical data speed signal					
DATAFLEX® Type	Inaccuracy ¹⁾ [%]	Output voltage [V]	Output of current [mA]	Band width [kHz]	Influence of temperature ¹⁾ [%/10 °C]	Resolution (pulses/rev.)	Number of channels	Square wave signal ²⁾ [Vss]	Direct-voltage signal ²⁾ [V]	Direction signal ²⁾ [V]
42/200	< ±0,5	0 ... 10	4 ... 20	16	0,5	60	1	5/24	0 ... 10, to be scaled	-
42/500										
42/1000										
Mechanical data of torque measuring shaft										
DATAFLEX® Type	Static load limit T_K max [%] ¹⁾	Breaking load T_K Break [%] ¹⁾	Max. bending moment [Nm]	Max. radial force [N]	Max. axial force [kN]	Weight [kg]	Torsion spring stiffness C_T [Nm/rad]	Twist angle with T_{KN} [°]	Mass moment of inertia [kgm ²]	Max. speed [rpm]
42/200	150	300	50	280	12	4,71	40929	0,28	0,0007343	6000
42/500			135	750	20	4,84	102321		0,0007603	
42/1000			270	1500	30	5,01	204643		0,0008048	

Dimensions (mm) of torque measuring shaft and coupling combination																
DATAFLEX® Type	d	D	L ₁	L ₂	L ₃	L ₄	L ₅	RADEX®-N Size	D ₁	D ₂	d ₁ /d ₂ max	E	L ₆	L ₇	L ₈	L _{Ges.}
42/200	42	130	232	55	122	114	6,5	60	138	88	60	11	232	55	254	364
42/500																
42/1000																

¹⁾ Referring to T_{KN}

²⁾ See page 314: connection housing DF2

Type 42/200, 42/500, 42/1000 – Accessories: RADEX®-N Steel laminae coupling

Mechanical data of the combination DATAFLEX® 42 and RADEX®-N									
DATAFLEX® Type	RADEX®-N Size	Coupling			Mechanical data of the entire system				
		Clamping screw M			Mass moment of inertia [kgm ²]	Torsion spring stiffness C_T [Nm/rad]	Weight [kg]	Max. speed [rpm] ³⁾	
G	t	T_A [Nm]							
42/200	60	M8	20	10	0,0173	29605	13,90	6000	
42/500					0,0174	52304	14,03		
42/1000	80	M10	20	17	0,0569	86888	24,39	5100	

³⁾ Higher speed on request

Order form	DATAFLEX® 42/500	DF2	2 m	RADEX®-N 60 NN Ø42/50NnD-Ø42/60NnD
Type of measuring shaft with measuring range	Connection housing selectable (DF1 or DF2)		Length of connection cable in metres	In case that accessories are requested: coupling type, finish bores d/d ₁ -d/d ₂

Type 85/2000, 85/5000, 85/10000



- DATAFLEX® 85 for high torques
- Contactless measurement
- Integrated speed signal
- Very wide signal band width
- Reliable values measured in the machine control, process control and test stand dynamometers
- Space-saving combination with servo lamina coupling RADEX®-N
- Compensating for angular, radial and axial displacements

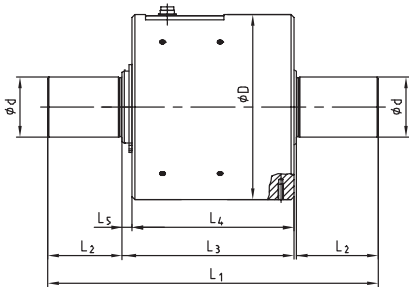

DATAFLEX® 85

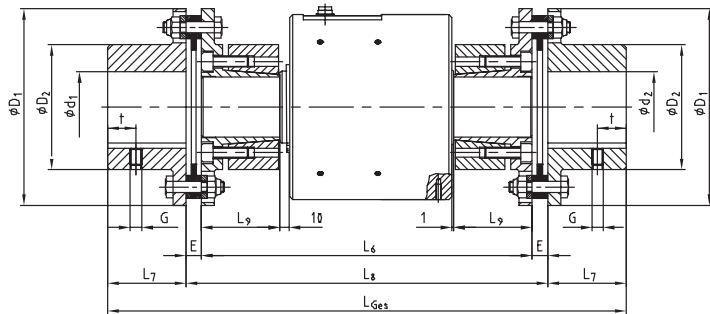

Combination of DATAFLEX® 85 with RADEX®-N

General features										
DATAFLEX® Type	Rated torque T_{KN} [Nm]		Distribution voltage [V]		Current consumption [mA]		Nominal temperature range [°C]			
85/2000	-2000 ... +2000		24 ± 4		< 100		0 ... 55			
85/5000	-5000 ... +5000									
85/10000	-10000 ... +10000									
Technical data torque signal						Technical data speed signal				
DATAFLEX® Type	Inaccuracy ¹⁾ [%]	Output voltage [V]	Output of current [mA]	Band width [kHz]	Influence of temperature ¹⁾ [%/10 °C]	Resolution (pulses/rev.)	Number of channels	Square wave signal ²⁾ [V _{ss}]	Direct-voltage signal ²⁾ [V]	Direction signal ²⁾ [V]
85/2000										
85/5000	< ±0,5	0 ... 10	4 ... 20	16	0,5	60	1	5/24	0 ... 10, to be scaled	-
85/10000										
Mechanical data of torque measuring shaft										
DATAFLEX® Type	Static load limit $T_{K \max}$ [%] ¹⁾	Breaking load $T_{K \text{ Break}}$ [%] ¹⁾	Max. bending moment [Nm]	Max. radial force [N]	Max. axial force [kN]	Weight [kg]	Torsion spring stiffness C_T [Nm/rad]	Twist angle with T_{KN} [°]	Mass moment of inertia [kgm ²]	Max. speed [rpm]
85/2000			380	1500	50	22,61	382000	0,30	0,01636	
85/5000	150	300	760	3000	80	23,23	818570	0,35	0,01679	2500
85/10000			1270	5000	110	23,85	1273330	0,45	0,01742	

Dimensions (mm) of torque measuring shaft and coupling combination																	
DATAFLEX® Type	d	D	L ₁	L ₂	L ₃	L ₄	L ₅	RADEX®-N Size	D ₁	D ₂	d ₁ /d ₂ max	E	L ₆	L ₇	L ₈	L ₉	L _{Ges}
85/2000								105	225	147	105	20	344	90	384	90	564
85/5000	85	215	344	90	164	153	10	115	265	163	115	23	364	100	410	100	610
85/10000								135	305	184	135	27	434	135	488	135	758

¹⁾ Referring to T_{KN}

²⁾ See page 314: connection housing DF2

Type 85/2000, 85/5000, 85/10000 – Accessories: RADEX®-N Steel laminae coupling

Mechanical data of the combination DATAFLEX® 85 and RADEX®-N								
DATAFLEX® Type	Coupling				Mechanical data of the entire system			
	RADEX®-N Size	Clamping screw M			Mass moment of inertia [kgm ²]	Torsion spring stiffness C_T [Nm/rad]	Weight [kg]	Max. speed [rpm] ³⁾
		M	t	T_A [Nm]				
85/2000	105	M12	30	40	0,2250	29300	61,48	
85/5000	115	M12	30	40	0,4735	55600	85,62	2500
85/10000	135	M20	40	140	1,0067	92800	130,16	

³⁾ Higher speed on request

Order form	DATAFLEX® 85/5000	DF2	2 m	RADEX®-N 115 NN Ø65/60NnD-Ø65/70NnD
	Type of measuring shaft with measuring range	Connection housing selectable (DF1 or DF2)	Length of connection cable in metres	In case that accessories are requested: coupling type, finish bores d/d_1 - d/d_2

Type 140/20000, 140/50000



- DATAFLEX® 140 for high torques
- Contactless measurement
- Integrated speed signal
- Very wide signal band width
- Reliable values measured in the machine control, process control and test stand dynamometers
- Coupling on request

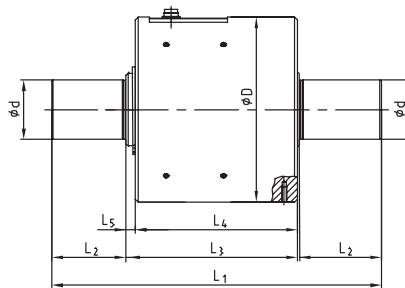

DATAFLEX® 140

General features										
DATAFLEX® Type	Rated torque T_{KN} [Nm]		Distribution voltage [V]		Current consumption [mA]		Nominal temperature range [°C]			
140/20000	-20000 ... +20000		24 ± 4		< 100		0 ... 55			
140/50000	-50000 ... +50000									
Technical data torque signal						Technical data speed signal				
DATAFLEX® Type	Inaccuracy ¹⁾ [%]	Output voltage [V]	Output of current [mA]	Band width [kHz]	Influence of temperature ¹⁾ [%/10 °C]	Resolution (pulses/rev.)	Number of channels	Square wave signal ²⁾ [Vss]	Direct-voltage signal ²⁾ [V]	Direction signal ²⁾ [V]
140/20000	< ±0,5	0 ... 10	4 ... 20	16	0,5	60	1	5/24	0 ... 10, to be scaled	-
140/50000										
Mechanical data of torque measuring shaft										
DATAFLEX® Type	Static load limit T_K max [%] ¹⁾	Breaking load T_K Break [%] ¹⁾	Max. bending moment [Nm]	Max. radial force [N]	Max. axial force [kN]	Weight [kg]	Torsion spring stiffness C_T [Nm/rad]	Twist angle with T_{KN} [°]	Mass moment of inertia [kgm ²]	Max. speed [rpm]
140/20000	150	300	2750	8000	100	73,9	3935000	0,30	0,17	2000
140/50000			5500	16000	160	76,5	6750000	0,42	0,175	
Dimensions (mm) of torque measuring shaft										
DATAFLEX® Type	d	D	L ₁	L ₂	L ₃	L ₄	L ₅			
140/20000	140	280	486	140	206	191	13			
140/50000										

¹⁾ Referring to T_{KN}

²⁾ See page 314: connection housing DF2

Order form	DATAFLEX® 140/50000	DF2	2 m
Type of measuring shaft with measuring range	Connection housing selectable (DF1 or DF2)		Length of connection cable in metres

Connecting housing DF2 and connecting cable



- Overall solution for all the DATAFLEX® series
- Comfortable speed output
Input output with reversible signal levels (5V/24V)
DC voltage output to scaleable via integrated frequency voltage converter (0 – 10V)
Direction signal (DATAFLEX® 16)
- Adjustable output filter for torque output
- Top assembly of top hat rail
- Integrated switch for automatic zero point correction
- Cable lengths of 2m, 5m and 10m available

