



BoWex® Curved-tooth gear couplings® are flexible shaft connections. They are able to compensate for shaft displacement caused by, as an example, inaccuracies in production, heat expansion, etc.

Table of Contents

1 Technical Data

2 Hints

- 2.1 General Hints
- 2.2 Safety and Advice Hints
- 2.3 General Hints to Danger
- 2.4 Proper Use

3 Storage

4 Assembly

- 4.1 Components of the Couplings
- 4.2 Hint Regarding the Finish Bore
- 4.3 Information about Shifting Power
- 4.4 Assembly of the Hubs
- 4.5 Displacements - Alignment of the Couplings
- 4.6 Assembly of Slip Ring for BoWex® SD1 and SD2
- 4.7 Maintenance Intervals for BoWex® SD1 and SD2
- 4.8 Assembly of Shiftable Linkage for BoWex® SD1 and SD2



1 Technical Data

Design SD

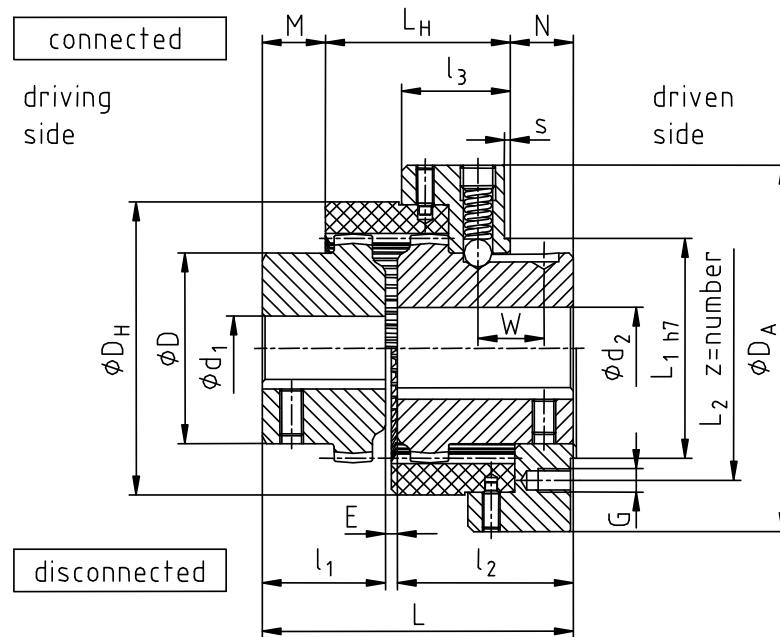

picture 1: BoWex® SD

Table 1:

BoWex® size	pilot bore		finish bore d ₁ ; d ₂		dimensions [mm]						
	un-bored	pilot bore	d ₁ max.	d ₂ max.	E	l ₁	l ₂	L	L _H	l ₃	M
24 SD	x	-	24	24	4	26	50	80	52	31	10
28 SD	x	-	28	28	4	40	55	99	57	33	21,5
32 SD	x	-	32	32	4	40	55	99	58	33	20,5
45 SD	x	-	45	45	4	42	60	106	63	37	21,5
			48					114			29,5
65 SD	x	27 70 lg.	65	65	4	55	70	129	79	37	26
80 SD	-	25	80	80	6	90	90	186	96	47	56
100 SD	-	35	100	100	8	110	110	228	113	55	72
125 SD	-	45	125	125	10	140	140	290	149	70	89

BoWex® size	dimensions [mm]					weight with max. bore		mass moment of inertia J with max. bore		shifting force [N]
	W	N	D	D _H	D _A	shifting hub with sleeve [kg]	driving hub [kg]	shifting hub with sleeve [kgcm ²]	driving hub [kgcm ²]	
24 SD	19	18	36	58	78	1,08	0,14	8,23	0,36	140
28 SD	21,5	20,5	44	70	88	1,50	0,33	15,62	1,22	180
32 SD	21,5	20,5	50	84	100	1,85	0,43	22,87	2,17	180
45 SD	22,5	21,5	65	100	125	2,56	0,68	46,07	5,66	250
							0,79			
65 SD	25	24	95	140	156	5,07	2,30	158,99	43,96	350
80 SD	35	34	124	175	195	10,60	5,20	523,7	150,8	350
100 SD	43	43	152	210	235	18,87	9,37	1350	401,3	400
125 SD	52	52	192	270	298	40,40	9,44	4919	1362,3	450



1 Technical Data

Design SD

Table 2:

connection dimensions of BoWex® SD shifting ring (part 17) for mounting of: slip ring SD1 – see table 5 (SD2 – see table 7), shifting disk etc.									
BoWex® size	dimensions [mm]				BoWex® size	dimensions [mm]			
	L ₁	L ₂	z x G	s		L ₁	L ₂	z x G	s
24 SD	48	58	4 x M6	2	65 SD	100	114	4 x M8	2
28 SD	48	58	4 x M6	2	80 SD	130	145	4 x M8	3
32 SD	64	75	4 x M6	2	100 SD	180	196	6 x M10	4
45 SD	75	90	4 x M8	2	125 SD	220	236	6 x M10	4

Table 3:

BoWex® size	power $\frac{P}{n}$ $\left[\frac{\text{kW}}{1/\text{min}} \right]$		torque T _K [Nm]			max. speed [1/min]
	nominal	max.	T _{KN}	T _{Kmax}	T _{KW}	
24 SD	0,0021	0,0042	20	40	10	5000
28 SD	0,0047	0,0094	45	90	23	4400
32 SD	0,0063	0,013	60	120	30	3900
45 SD	0,015	0,029	140	280	70	3100
65 SD	0,040	0,080	380	760	190	2500
80 SD	0,073	0,15	700	1400	350	2000
100 SD	0,13	0,25	1200	2400	600	1650
125 SD	0,26	0,52	2500	5000	1250	1300



1 Technical Data

Design SD1 with slip ring and shiftable linkage

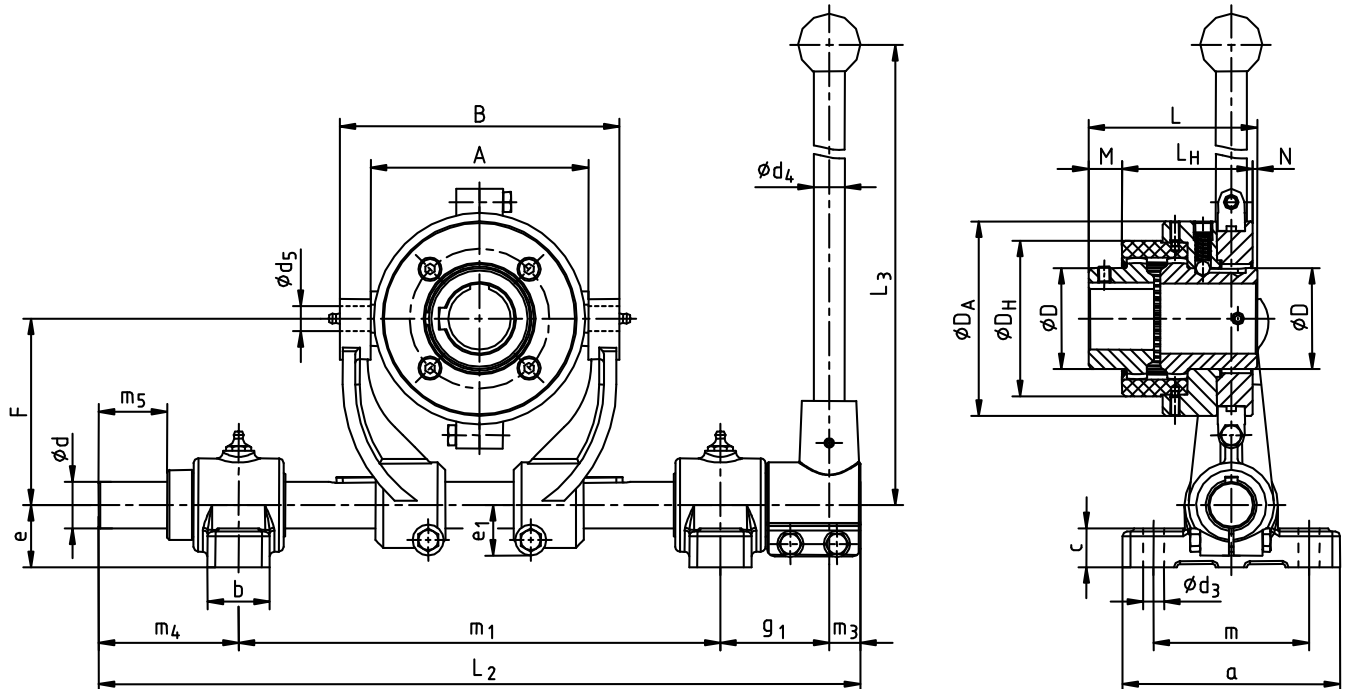

picture 2: BoWex® SD1 with shiftable linkage

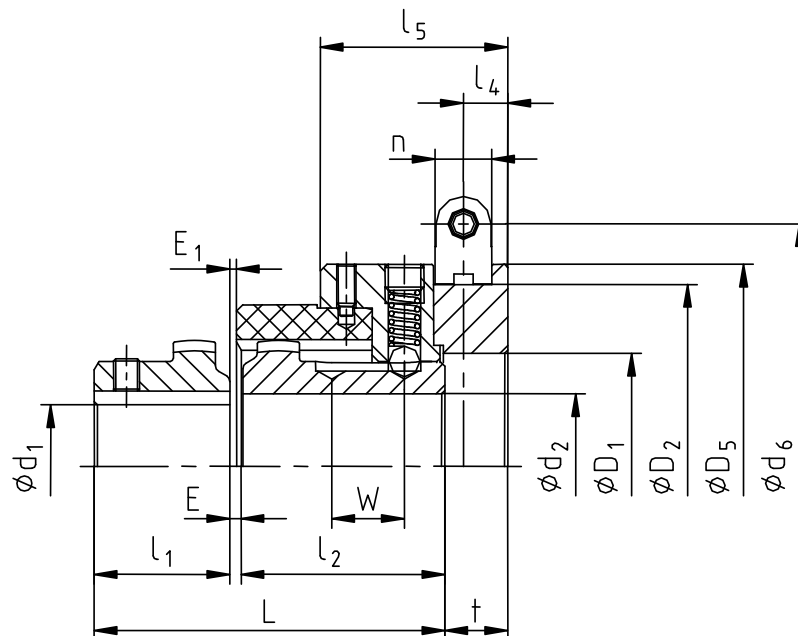

picture 3: BoWex® SD1

Schutzvermerk ISO 16016 beachten.	Gezeichnet: 30.09.08 Pz/Schb	Ersatz für: KTR-N vom 04.11.05
	Geprüft: 30.09.08 Pz	Ersetzt durch:



1 Technical Data

Design SD1

Table 4:

BoWex® size	finish bore ¹⁾ d ₁ /d ₂		dimensions of der BoWex® coupling type SD1								
	min.	max.	E	E ₁	l ₁	l ₂	L	L _H	l ₄	l ₅	M
24 SD1	10	24	4	3	26	50	80	67	11	46	10
28 SD1	10	28	4	3	40	55	99	72	11	48	21,5
32 SD1	12	32	4	2	40	55	99	78	13,5	53	20,5
45 SD1	20	45	4	2	42	60	106	84	14	58	21,5
					50		114				29,5
65 SD1	25	65	4	-4 ²⁾	55 ²⁾	70	129	103	16	61	26
80 SD1	30	80	6	1	90	90	186	124	18,5	75	56
100 SD1	40	100	8	5	110	110	228	152	28	94	72
125 SD1	50	125	10	1	140	140	290	193	30,5	114	89

BoWex® size	dimensions of der BoWex® coupling type SD1										Shifting power set [N]
	N	W	t	D	D _H	D _A	D ₁	D ₂ ±0,1 (keyway)	D ₅	n ±0,1 (keyway)	
24 SD1	3	19	16	36	58	78	45	70,5	78	12,5	140
28 SD1	5,5	21,5	16	44	70	88	45	70,5	78	12,5	180
32 SD1	0,5	21,5	21	50	84	100	60	89,5	100	17,5	180
45 SD1	0,5	22,5	22	65 ³⁾	100	125	70	112,5	125	18	250
65 SD1	0	25	25	96 / 95 ⁶⁾	140	156	96	130,5	145	20,5	350
80 SD1	6	35	29	124	175	195	125	164,5	182	25,5	350
100 SD1	4	43	39	152	210	235	174	210,5	230	30,5	400
125 SD1	8	52	44	192	270	298	214	250,5	275	35,5	450

Table 5:

BoWex® size	shiftable linkage size	slip ring size	dimensions of shifting device									
			a	b	c	d	d ₃	d ₅	d ₆	e	e ₁	F
24 SD1	1	1.1	110	35	18	20	11	12	94	30	25	70
28 SD1	1	1.1	110	35	18	20	11	12	94	30	25	70
32 SD1	2	2.2	140	40	25	25	13,5	17	120	40	27	97,5
45 SD1	3	3.3	140	40	25	30	13,5	17	146	40	32,5	120
65 SD1	3	4.4	140	40	25	30	13,5	17	170	40	32,5	120
80 SD1	4	5.5	160	45	25	35	13,5	21	214	50	37,5	147,5
100 SD1	5	6.6	160	45	25	40	13,5	25	250	50 ⁵⁾	46	190
125 SD1	5	7.7	160	45	25	40	13,5	25	290	50 ⁵⁾	46	190

BoWex® size	dimensions of shifting device											
	g ₁ ⁴⁾	L ₂	L ₃	m	m ₁ ⁴⁾		A	B	dimensions with m _{1 max.}			
					min.	max.			d ₄	m ₃	m ₄	m ₅
24 SD1	55	320	400	75	180	190	90	114	16	20	55	16
28 SD1	55	320	400	75	180	190	90	114	16	20	55	16
32 SD1	60	430	450	100	240	270	111	151	20	20	80	34
45 SD1	70	490	600	100	280	310	140	180	20	20	90	44
65 SD1	70	490	600	100	280	310	170	210	20	20	90	44
80 SD1	70	565	750	120	321	365	200	244	30	30	100	54
100 SD1	80	630	1068	120	365	410	250	300	30	30	110	62
125 SD1	80	630	1068	120	-	410	300	350	30	30	110	62

- 1) Finish bore according to ISO fit H7, keyway for feather key according to DIN 6885 sheet 1 (JS9); standard – thread for setscrews on the keyway. For size 24 the thread for setscrews is situated opposite to the keyway.
- 2) For a radial disassembly the hub collar has to be reduced by 5 mm.
- 3) For size 45 hub part 1 with l₁ = 50 mm, ØD = 68 mm.
- 4) Dimensions g₁ and m_{1 max.} = standard assembly dimensions.
- 5) With a continuous base plate the dimension e with shiftable linkage size 5 has to be increased by 10 mm at the minimum and with shiftable linkage size 6 by 15 mm at the minimum. The brackets of the driving and driven side have to be adjusted accordingly.
- 6) ØD = x / y x = driving hub / y = driven hub
- 7) Only valid for dimension d₁.

Schutzvermerk ISO 16016 beachten.	Gezeichnet:	30.09.08 Pz/Scb	Ersatz für:	KTR-N vom 04.11.05
	Geprüft:	30.09.08 Pz	Ersetzt durch:	



1 Technical Data

Design SD2

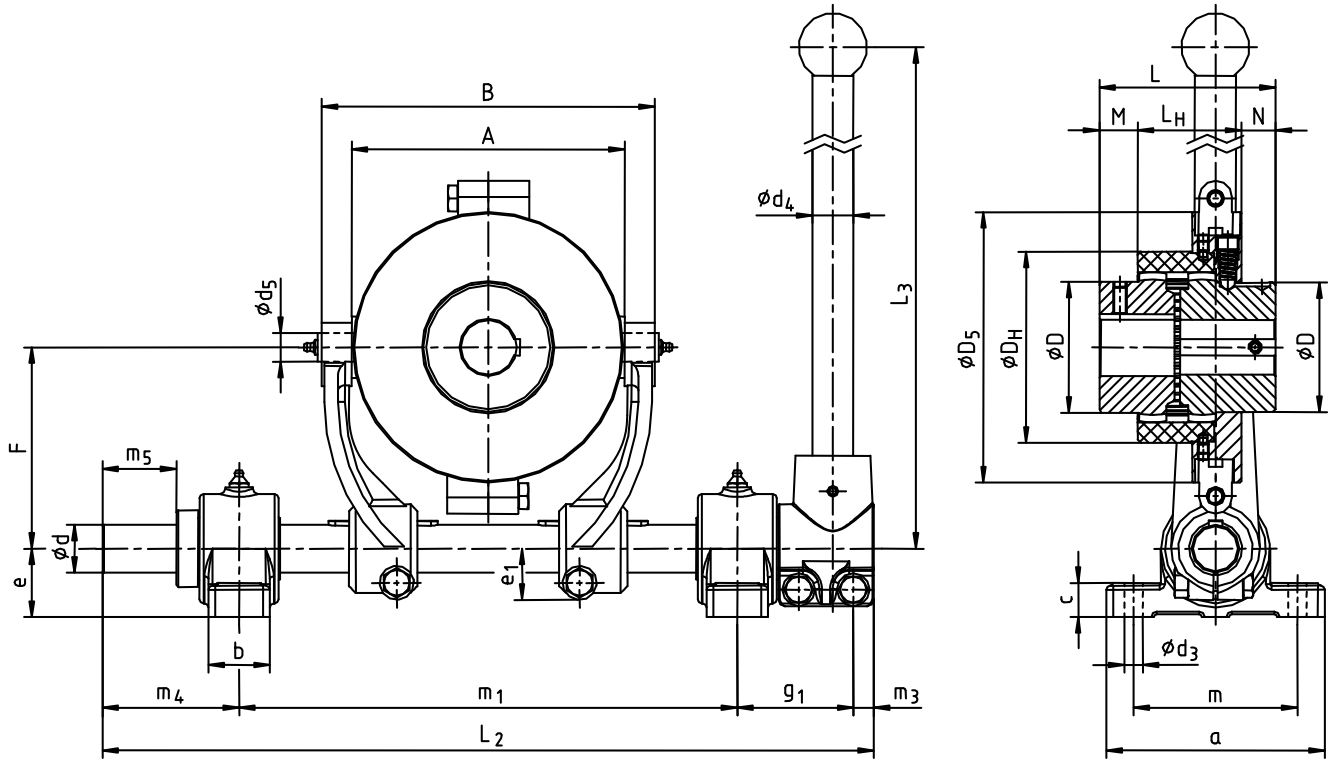

picture 4: BoWex® SD2 with shiftable linkage

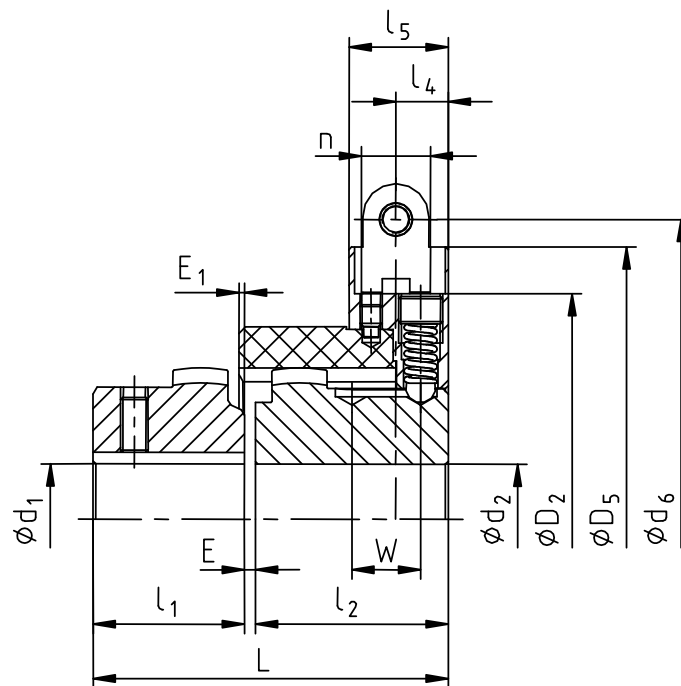

picture 5: BoWex® SD2

Schutzvermerk ISO 16016 beachten.	Gezeichnet: 30.09.08 Pz/Schb	Ersatz für: KTR-N vom 04.11.05
	Geprüft: 30.09.08 Pz	Ersetzt durch:



1 Technical Data

Design SD2

Table 6:

BoWex® size	finish bore ¹⁾ d ₁ /d ₂		dimensions of BoWex® coupling type SD2							
	min.	max.	E	E ₁	l ₁	l ₂	L	L _H	l ₄	l ₅
24 SD2	10	24	4	3	26	50	80	51	9,5	30
28 SD2	10	28	4	3	40	55	99	56	16	32
32 SD2	12	32	4	2	40	55	99	57	16	32
45 SD2	20	45	4	2	42	60	106	62	16	36
		48 ⁷⁾			50					
65 SD2	25	65	4	-4 ²⁾	55 ²⁾	70	129	78	18	36
80 SD2	30	80	6	1	90	90	186	95	23	46
100 SD2	40	100	8	5	110	110	228	113	28	55
125 SD2	50	125	10	1	140	140	290	149	30	70

BoWex® size	dimensions of BoWex® coupling type SD2								Shifting power set [N]
	M	N	W	D	D _H	D ₂ ±0,1 (keyway)	D ₅	n ±0,1 (keyway)	
24 SD2	10	19	19	36	58	70,5	88	12,5	140
28 SD2	21,5	21,5	21,5	44	70	89,5	113	17,5	180
32 SD2	20,5	21,5	21,5	50	84	112,5	136	18	180
45 SD2	21,5	22,5	22,5	65 ³⁾	100	130,5	154	20,5	250
	29,5								
65 SD2	26	25	25	96 / 95 ⁶⁾	140	164,5	198	25,5	350
80 SD2	56	35	35	124	175	210,5	250	30,5	350
100 SD2	72	43	43	152	210	250,5	295	35,5	400
125 SD2	89	52	52	192	270	300,5	355	38,5	450

Table 7:

BoWex® size	shiftable linkage size	slip ring size	dimensions of shifting device									
			a	b	c	d	d ₃	d ₅	d ₆	e	e ₁	F
24 SD2	1	1.1	110	35	18	20	11	12	94	30	25	70
28 SD2	2	2.2	140	40	25	25	13,5	17	120	40	27	97,5
32 SD2	3	3.3	140	40	25	30	13,5	17	146	40	32,5	120
45 SD2	3	4.4	140	40	25	30	13,5	17	170	40	32,5	120
65 SD2	4	5.5	160	45	25	35	13,5	21	214	50	37,5	147,5
80 SD2	5	6.6	160	45	25	40	13,5	25	250	50 ⁵⁾	46	190
100 SD2	5	7.7	160	45	25	40	13,5	25	290	50 ⁵⁾	46	190
125 SD2	6	8.8	160	45	25	40	13,5	35	360	50 ⁵⁾	56	265

BoWex® size	dimensions of shifting device											
	g ₁ ⁴⁾	L ₂	L ₃	m	m ₁ ⁴⁾		A	B	dimensions with m _{1 max.}			
					min.	max.			d ₄	m ₃	m ₄	m ₅
24 SD2	55	320	400	75	180	190	90	114	16	20	55	16
28 SD2	60	430	450	100	240	270	111	151	20	20	80	34
32 SD2	70	490	600	100	280	310	140	180	20	20	90	44
45 SD2	70	490	600	100	280	310	170	210	20	20	90	44
65 SD2	70	565	750	120	321	365	200	244	30	30	100	54
80 SD2	80	630	1068	120	365	410	250	300	30	30	110	62
100 SD2	80	630	1068	120	-	410	300	350	30	30	110	62
125 SD2	80	760	1068	120	-	540	360	420	30	30	110	62

- 1) Finish bore according to ISO fit H7, keyway for feather key according to DIN 6885 sheet 1 (JS9); standard – thread for setscrews on the keyway. For size 24 the thread for setscrews is situated opposite to the keyway.
- 2) For a radial disassembly the hub collar has to be reduced by 5 mm.
- 3) For size 45 hub part 1 with l₁ = 50 mm, ØD = 68 mm.
- 4) Dimensions g₁ and m_{1 max.} = standard assembly dimensions.
- 5) With a continuous base plate the dimension e with shiftable linkage size 5 has to be increased by 10 mm at the minimum and with shiftable linkage size 6 by 15 mm at the minimum. The brackets of the driving and driven side have to be adjusted accordingly.
- 6) ØD = x / y x = driving hub / y = driving hub
- 7) Only valid for dimension d₁.

Schutzvermerk ISO 16016 beachten.	Gezeichnet:	30.09.08 Pz/Scb	Ersatz für:	KTR-N vom 04.11.05
	Geprüft:	30.09.08 Pz	Ersetzt durch:	



2 Hints

2.1 General Hints

Please read through these mounting instructions carefully before you set the coupling into operation. Please pay special attention to the safety instructions!
The mounting instructions are part of your product. Please keep them carefully and close to the coupling. The copyright for these mounting instructions remains with **KTR Kupplungstechnik GmbH**.

2.2 Safety and Advice Hints



DANGER!

Danger of injury to persons.



CAUTION!

Damages on the machine possible.



ATTENTION!

Pointing to important items.

2.3 General Hints of Danger



DANGER!

With assembly, operation and maintenance of the coupling it has to be made sure that the entire drive train is protected against unintentional engagement. You can be seriously hurt by rotating parts. Please make absolutely sure to read through and observe the following safety instructions.

- All operations on and with the coupling have to be performed taking into account "safety first".
- Please make sure to disengage the power pack before you perform your work.
- Protect the power pack against unintentional engagement, e. g. by providing hints at the place of engagement or removing the fuse for current supply.
- Do not touch the operation area of the coupling as long as it is in operation.
- Please protect the coupling against unintentional touch. Please provide for the necessary protection devices and caps.

2.4 Proper Use

You may only assemble, operate and maintain the coupling if you

- carefully read through the mounting instructions and understood them
- had technical training
- are authorized to do so by your company

The coupling may only be used in accordance with the technical data (see table 1 to 7 in chapter 1). Unauthorized modifications on the coupling design are not admissible. We do not take any warranty for resulting damages. To further develop the product we reserve the right for technical modifications.
The **BoWex®** described in here corresponds to the technical status at the time of printing of these mounting instructions.

Schutzvermerk ISO 16016 beachten.	Gezeichnet: 30.09.08 Pz/Schb	Ersatz für: KTR-N vom 04.11.05
	Geprüft: 30.09.08 Pz	Ersetzt durch:



3 Storage

The coupling hubs are supplied in preserved condition and can be stored at a dry and roofed place for 6 - 9 months.

The features of the coupling sleeves remain unchanged for up to 5 years in case of favourable stock conditions.



CAUTION!

The storage rooms may not include any ozone-generating devices, like e. g. fluorescent light sources, mercury-vapour lamps or electrical high-voltage appliances.
Humid storage rooms are not suitable.

Please make sure that there is no condensation. The best relative air humidity is under 65%.

4 Assembly

The coupling is generally supplied in a preassembled condition with the shifting power adjusted (see tables 1, 4 and 6). Before assembly the coupling has to be controlled for completeness.

4.1 Components of the Couplings

Components of BoWex® SD design No. 009

Component	Quantity	Designation
1	1	hub
2	1	shifting part
3	2	setscrew DIN EN ISO 4029

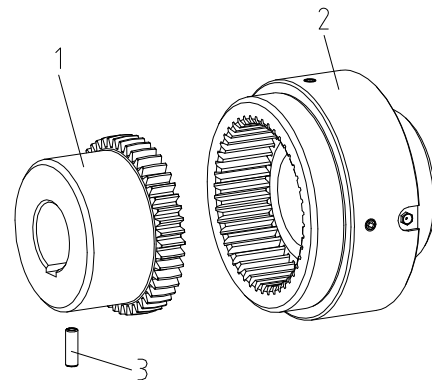

picture 6: BoWex® SD

Components of BoWex® SD1 with shiftable linkage

Component	Quantity	Designation
1	1	hub
2	1	shifting part
3	1	shiftable linkage
4	1	slip ring
5	2	setscrew DIN EN ISO 4029

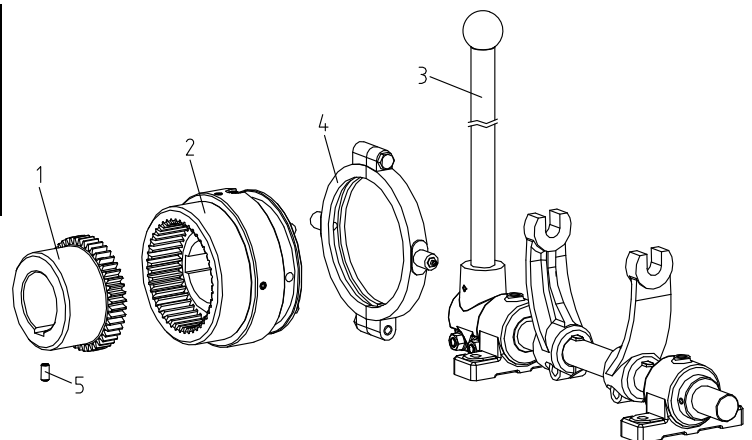

picture 7: BoWex® SD1



4 Assembly

4.1 Components of the Couplings

Components of BoWex® SD2 with shiftable linkage

Component	Quantity	Designation
1	1	hub
2	1	shifting part
3	1	shiftable linkage
4	1	slip ring
5	2	setscrew DIN EN ISO 4029

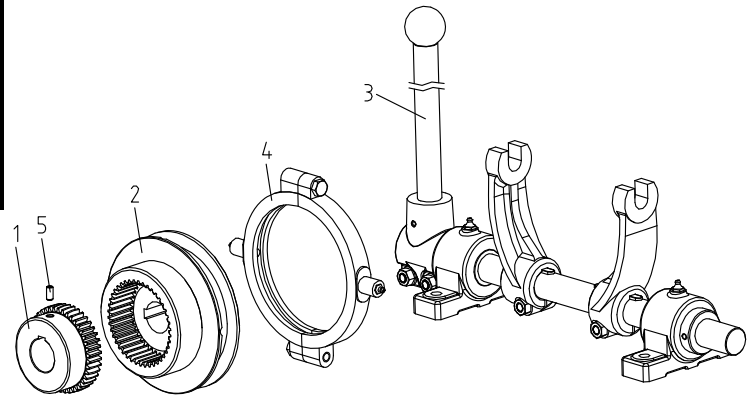

picture 8: BoWex® SD1

4.2 Hint Regarding the Finish Bore



DANGER!

The maximum permissible bore diameters d (see table 1, 4 and 6 in chapter 1 - Technical Data) must not be exceeded. If these figures are disregarded, the coupling may tear. Rotating particles may cause serious danger.

- Hub bores machined by the customer have to observe concentric running or axial running, respectively (see picture 9).
- Please make absolutely sure to observe the figures for d_{max} .
- Carefully align the hubs when the finish bores are brought in.
- Please provide for a setscrew or an end plate for the axial fastening of the hubs.

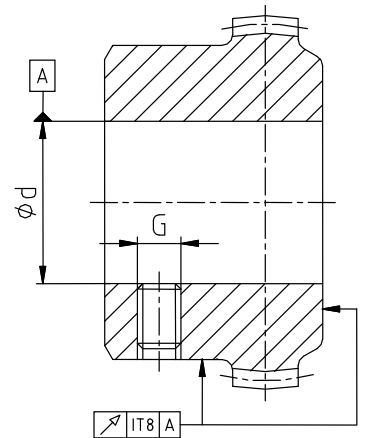

picture 9: concentric running and axial running

Table 8: Setscrews DIN EN ISO 4029

BoWex® size	24	28	32	45	65	80	100	125
screw size	M5	M8	M8	M8	M10	M10	M12	M16
tightening torque T_A [Nm]	2	10	10	10	17	17	40	80

4.3 Information about Shifting Power



ATTENTION!

Before delivery the shifting power is adjusted and the screw plug is marked with marking lacquer.



4 Assembly

4.4 Assembly of the Hubs



ATTENTION!

We recommend to check bores, shaft, keyway and feather key for dimensional accuracy before assembly.

Heating the hubs slightly (approx. 80 °C) allows for an easier installation onto the shaft.



DANGER!

Touching the heated hubs causes burns.
We would recommend to wear safety gloves.



CAUTION!

For the assembly please make sure that the distance dimension E (see table 1, 4 and 6) is kept to ensure that the sleeve can be moved axially.
Disregarding this hint may cause damage on the coupling.

- Please assemble the hubs onto the shaft of the driving side and the shifting part onto the shaft of the driven side.
- Move the power packs in axial direction until the dimension E is achieved.
- If the power packs are already firmly assembled, axial movement of the hubs on the shafts allows for adjusting the dimension E.
- Fasten the hubs by tightening the setscrews DIN EN ISO 4029 with cup point.

4.5 Displacements – Alignment of the Couplings

The displacement figures shown in table 9 offer sufficient safety to compensate for environmental influences like, for example, heat expansion or lowering of foundation.



CAUTION!

In order to ensure a long lifetime of the coupling, the shaft ends must be accurately aligned. Please absolutely observe the displacement figures indicated (see table 9). If the figures are exceeded, the coupling is damaged.

Please note:

- The displacement figures mentioned in table 9 are maximum figures which must not arise in parallel. If radial and angular displacement arises at the same time, the permissible radial displacements of the coupling halves have to be reduced as follows:

$$\Delta K_{r_{perm}} = \Delta K_r - \frac{\Delta K_r}{2\Delta K_w} \cdot \Delta W_w$$

ΔW_w = angular shaft displacement

- The displacement figures mentioned are general figures that apply up to an ambient temperature of 80 °C, ensuring a sufficient service life of the **BoWex®** coupling.
- Please check with a dial gauge, ruler or feeler whether the permissible displacement figures of table 9 can be observed.

Schutzvermerk ISO 16016 beachten.	Gezeichnet: 30.09.08 Pz/Sch	Ersatz für: KTR-N vom 04.11.05
	Geprüft: 30.09.08 Pz	Ersetzt durch:



4 Assembly

4.5 Displacements – Alignment of the Couplings

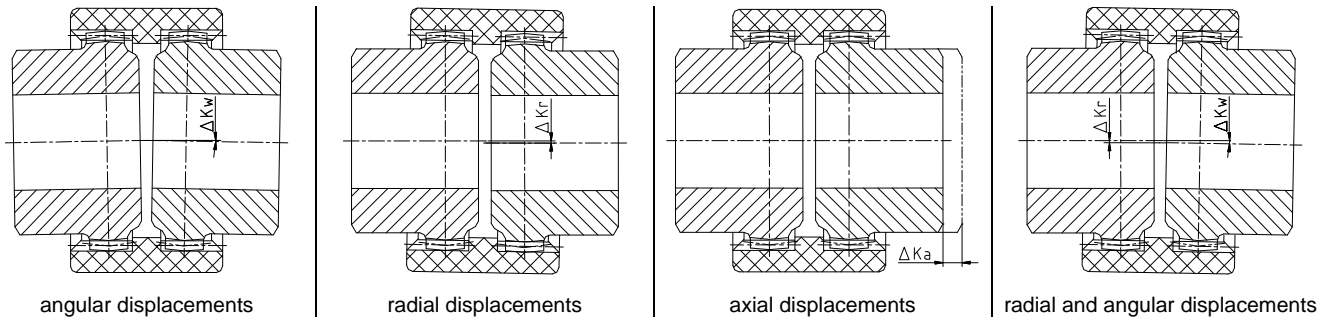

picture 10: displacements

Example for the misalignment combinations given in picture 11:

Example 1:

$\Delta K_R = 30\%$

$\Delta K_W = 70\%$

Example 2:

$\Delta K_R = 60\%$

$\Delta K_W = 40\%$

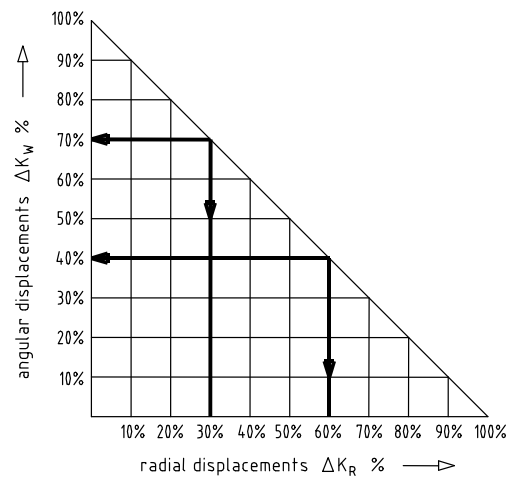

picture 11: combinations of displacement

$\Delta K_{total} = \Delta K_R + \Delta K_W \leq 100\%$

Tabelle 9: displacement figures

coupling size	24	28	32	45	65	80	100	125
max. axial displacement ΔK_a [mm]	± 1	± 1	± 1	± 1	± 1	± 1	± 1	± 1
max. radial displacement with $n=1500$ 1/min ΔK_r [mm]	0,2	0,2	0,25	0,25	0,3	0,3	0,3	0,3
ΔK_w max. angular displacement with $n=1500$ 1/min [degree]	1	1	1	1	1	1	1	1

4.6 Assembly of Slip Ring for BoWex® SD1 and SD2

- Before assembly please inspect the slip ring (component 1, picture 12) to see whether a lubricating nipple/Stauffer lubricator or damages exist.
- Before separating the slip ring halves please mark the position of the slip ring halves screwed by the manufacturer.
- Please insert the untightened slip ring halves into the shifting keyway of the coupling.



CAUTION!

For the assembly please pay attention to the position of the slip ring halves marked.

Schutzvermerk ISO 16016 beachten.	Gezeichnet: 30.09.08 Pz/Schb	Ersatz für: KTR-N vom 04.11.05
	Geprüft: 30.09.08 Pz	Ersetzt durch:



4 Assembly

4.6 Assembly of Slip Ring for BoWex® SD1 and SD2

Continuation:

- Please tighten the connection screws with a dynamometric screwdriver. For tightening torques see table 10.



CAUTION!

After assembly the slip ring has to be in a position to be turned manually.

Table 10:

slip ring size	1.1	2.2	3.3	4.4	5.5	6.6	7.7	8.8
screw DIN EN ISO 4017 - 8.8	M6	M8	M8	M10	M12	M16	M16	M16
tightening torque T_A [Nm]	10	25	25	49	86	210	210	210
max. perm. speed 1/min	3200	2500	2100	1700	1300	1200	1000	850

- Grease the slip ring through the lubricating nipple/Stauffer lubricator with a heat resistant bearing grease while turning the slip ring manually repeatedly.
Slip ring – max. permissible speed see table 10.

4.7 Maintenance Intervals for BoWex® SD1 and SD2

Shifting hub:

- Within the framework of the machine inspection periods the fit of the shifting hub has to be cleaned and lubricated (e. g. with a Molykote MoS₂ copper paste).
- With a high shifting frequency of the coupling we would recommend one visual inspection and lubricating of the shifting hub monthly.
- In case of an operation with dust and granular material as well as high air moisture one visual inspection and lubricating per month and an operational inspection every three months has to be performed (engagement/disengagement of the coupling during standstill).

Slip ring:

- Before every lubricating the slip ring has to be inspected for damages (visual inspection).
- The shifting hub part has to be in a position to be turned manually in the slip ring.
- The lubrication of the slip ring depends on the speed and the operating periods of the machine (see table 11).
- The intervals for inspection and lubrication mentioned apply for drives with standard load.



ATTENTION!

For drives with high load, e. g. permanent operation during 3 shifts, hot operation, etc., please consult with our engineers.

Table 11:

max. perm. speed (1/min) of the slip ring	3200 to 2100		1700 to 1000		850 to 700	
daily operating period of machines (h)	8 h	16 h	8 h	16 h	8 h	16 h
visual inspection and lubrication intervals	0,5 months		1 months	0,5 months	1,5 months	1 months



CAUTION!

For certain applications, e. g. operation with dust and granulated materials, high air moisture, high ambient temperatures, outdoor operations, etc., the intervals of visual inspections and lubrication have to be reduced.

Schutzvermerk ISO 16016 beachten.	Gezeichnet: 30.09.08 Pz/Scb	Ersatz für: KTR-N vom 04.11.05
	Geprüft: 30.09.08 Pz	Ersetzt durch:



4 Assembly

4.8 Assembly of Shiftable Linkage for BoWex® SD1 and SD2

Before starting the assembly the coupling/shiftable linkage have to be inspected with regard to completeness.

Component	Quantity	Designation
1	1	slip ring with lubricating nipple
2	2	shifting fork
3	1	shift lever with clamping element
4	2	eye type bearing DIN 504 with lubricating nipple
5	1	shifting shaft
6	1	clamping ring
7	2	clamping screws of shifting forks
8	2	clamping screws of shift lever

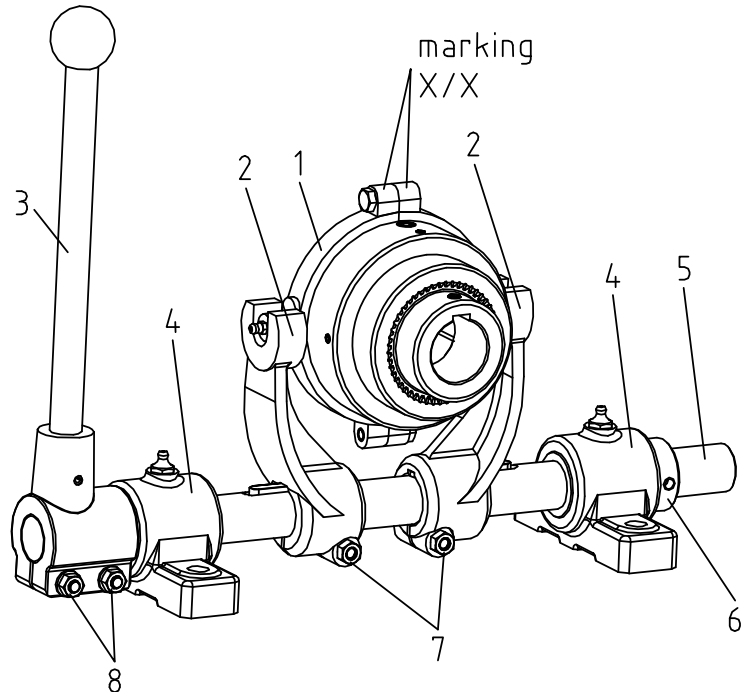

picture 12: BoWex® SD with shiftable linkage

- Please insert the shifting plug/slip ring into the shifting forks (component 2, picture 12).
- Assemble the shifting forks, shifting shaft and eye type bearings in alignment with the slip ring. The dimensions F and A have to be adhered to (see tables 5 and 7). Please make sure that the shifting forks fit with the shifting spigots evenly.



ATTENTION!

For setting please untighten the clamping screws of the shifting forks, if necessary.



CAUTION!

The shifting forks have to be installed vertically to the base plate.



DANGER!

Getting stuck and jamming of the slip ring during operation.

- Please tighten the shifting forks as per table 12.
- Fasten the eye type bearing to the base plate.



CAUTION!

With a continuous base plate the dimension e (see tables 5 and 7) with shiftable linkage size 5 has to be increased by 10 mm at the minimum and with shiftable linkage size 6 by 15 mm at the minimum. The brackets of the driving and driven side have to be adjusted accordingly.



4 Assembly

4.8 Assembly of Shiftable Linkage for BoWex® SD1 and SD2

Continuation:

- Fasten the shift lever to the shifting shaft.
- When the coupling is engaged, the shifting lever has to be installed vertically.



CAUTION!

When the coupling hub is in operation the slip ring has to be disengaged. Support or secure the shifting lever in vertical position.



DANGER!

Getting stuck and jamming of the slip ring during operation.

- Please tighten the clamping screws of the shift lever as per table 12.
- Axially fasten the shifting shaft via clamping element, shift lever and clamping ring (component 6, picture 12).
- Having finished the assembly please lubricate the eye type bearing with bearing lubricant.

Table 12:

shiftable linkage size	1	2	3	4	5	6
clamping screw of shifting fork (component 7, picture 12)	M6	M8	M8	M12	M12	M12
tightening torque T_A [Nm]	10	25	25	86	86	86
clamping screw of shift lever (component 8, picture 12)	M6	M6	M8	M12	M12	M12
tightening torque T_A [Nm]	10	10	25	86	86	86