

Zahnkranz/ spider:
 92 Sh A T-PUR orange/ orange
 (92 Sh A PUR gelb/ yellow)
 Drehmoment/ Torque
 $T_{KN} = 190Nm$
 $T_{Kmax} = 380Nm$

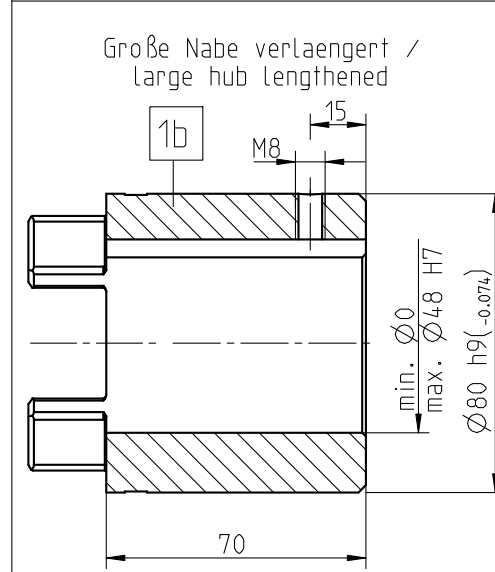

Zahnkranz/ spider:
 98 Sh A T-PUR lila/ purple
 (98 Sh A PUR rot/ red)
 Drehmoment/ Torque
 $T_{KN} = 325Nm$
 $T_{Kmax} = 650Nm$

Zahnkranz/ spider:
 64 Sh D T-PUR grün/ green
 64 Sh D PUR natur-weiß mit
 grüner Zahnmarkierung /
 natural white with
 green tooth marking
 Drehmoment/ Torque
 $T_{KN} = 405Nm$
 $T_{Kmax} = 810Nm$
 Vor Einsatz Rucksprache KTR/
 before inserting please consult KTR

weitere Nabenausführungen/
 other hub desings

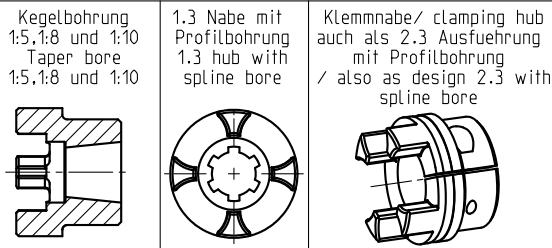

Nabenwerkstoff: 11SMn30C
 hub material: 11SMn30C

Paßfedernute nach DIN 6885 Bl. 1-JS9
 keyway acc. to DIN 6885 sheet 1-JS9

Oberflächenguete nach DIN ISO 1302 Reihe 2
 Surface quality acc. to DIN ISO 1302 line 2
 Allgmeintoleranzen nach DIN ISO 2768 - mH
 General tolerances acc. to DIN ISO 2768 - mH

Schutzvermerk ISO 16016 beachten
 Note protection mark acc. to ISO 16016
 Maßstab Scale: 6:5
 Format DIN Size: A3

ROTEX 38
 Standard

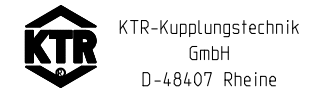

gezeichnet drawn	Werkstoff Material	Teilnummer Part number	Kz	Lfd.-Nr. Current number	Index Change
Datum 05.12.11	DIN		M	447907	2
Name SCHP	Gewicht Weight				