

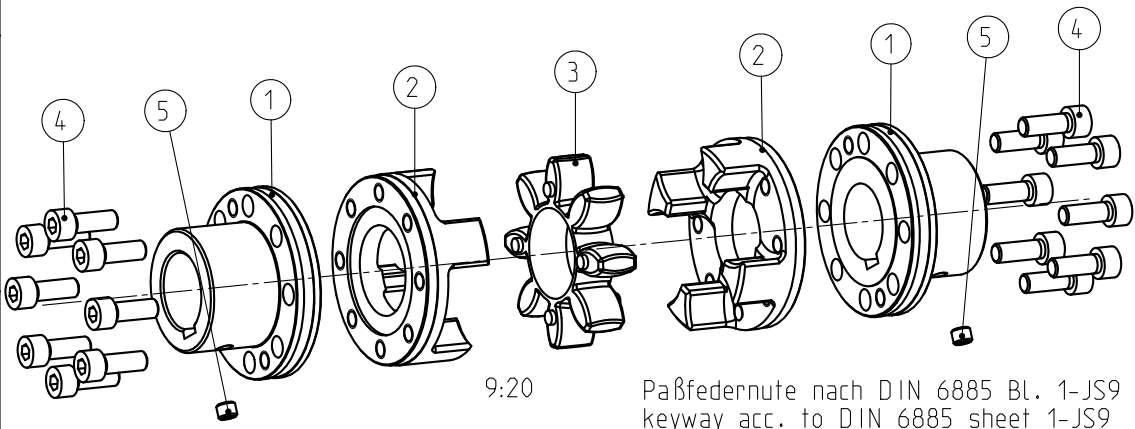

Massenträgheitsmoment / Mass moment of inertia
 $J_{ges} = 0.00194440 \text{ kgm}^2$

Drehmoment / Torque
 Zahnkranz / spider 92 Sh A
 $T_{KN} = 190 \text{ Nm}$
 $T_{Kmax} = 380 \text{ Nm}$



Schraubenanzugsmoment Teil 4 DIN EN ISO 4762-M8x22-12.9, $T_A = 41 \text{ Nm}$
 screw tightening torque part 4 DIN EN ISO 4762-M8x22-12.9, $T_A = 41 \text{ Nm}$

Oberflächenguete nach DIN ISO 1302 Reihe 2 Surface quality acc. to DIN ISO 1302 line 2		Schutzvermerk ISO 16016 beachten Note protection mark acc. to ISO 16016	
Allgemeintoleranzen nach DIN ISO 2768 - mH General tolerances acc. to DIN ISO 2768-		Masstab Scale	9:10
		Format DIN Size	A3
ROTEX 38 AFN			
		 KTR-Kupplungstechnik GmbH D-48407 Rheine	
gezeichnet drawn	Werkstoff Material	Teilnummer Part number	Kz
Datum 19.05.05	DIN		Lfd.-Nr. Current number
Name KO	Gewicht Weight	2.396	Index Change
		M	430519
			0

Bei Fertigbohrung über $\varnothing 34$ befindet sich das Feststellgewinde M8 gegenüber der Nut.
 In case of finish bore more than $\varnothing 34$ the locking thread M8 is oppsite to the keyway.